



INSTRUCTIONS and PARTS LIST

**SERIES N3D
PUMP SIZES 250 AND 275**

WARNING

**READ CA-1 AND THIS INSTRUCTION BOOK BEFORE
INSTALLATION, OPERATION, OR MAINTENANCE**

INSTRUCTIONS N3D-B (R-1)

This manual now is
identified as part no.
SRM00066

FOREWORD

This instruction manual covers the Series N3D Series Imo Delaval Inc. IMO Pump size 250 and 275. The specific models covered by this manual are identified in Table 1. Refer to the assembly drawing, Figures 4 through 6, corresponding to your pump type as you use this instruction manual. The type of each particular pump is identified on the pump nameplate. Refer to Figure 1 for definition of type designator.

The inserted CA-1 book deals with installation, operation, maintenance and troubleshooting that cover the entire range of pumps. The maintenance section of this manual covers disassembly and assembly procedure.

The Series N3D pumps and their appurtenances are designed, fabricated, inspected, tested and stamped in accordance with Section III, Class 3 of the ASME Boiler and Pressure Vessel Code. All internal wearing and sealing parts are standard commercial parts and can be replaced readily. All pressure retaining parts must be purchased in accordance with applicable ASME Code requirements.

TABLE 1
N3D SERIES IMO PUMP TYPES

Pump Type	Assembly Drawing No.	Figure No.	Pump Type	Assembly Drawing No.	Figure No.
N3DBS-250	SD-5542	4	NA3DVS-275	SF-5633	5
N3DHS-250	SD-5542	4	NB3DVS-275	SF-5704	6

ORDERING INSTRUCTIONS

All correspondence pertaining to renewal parts for the equipment must refer to the instruction book number and should be addressed to the nearest IMO Pump Division sales office or representative listed in the CA-1 book.

The handling of renewal orders will be greatly facilitated if the following directions are carefully observed.

1. Give the number of the instruction book.
2. Give the serial number of the machine for which part is desired. This number appears on the nameplate.
3. Designate the desired part by the number and names as listed in this instruction book.
4. Give the drawing number or figure number in which the part is shown.

STRUCTURAL LIMITS

Operating conditions, such as speed, fluid viscosity, inlet pressure, discharge pressure, temperature, filtration, duty cycle, mounting, drive type, etc. are interrelated. Due to these variable conditions, the specific application may be different from that of the structural limitations. This equipment must not be operated without verification that operating requirements are within published capabilities as shown in the appropriate pump data book (available from local IMO Pump Division offices and representatives).

Under no circumstances are the following structural limitations to be exceeded.

DISCHARGE PRESSURE: 150 PSIG (Maximum)

MAXIMUM SPEED: 4400 RPM

VISCOSITY: 32 SSU Minimum
3000 SSU Maximum

TEMPERATURE: 0° to 160°F for type B Shaft Seal
0° to 200°F for type V Shaft Seal
0° to 250°F for type H Shaft Seal

SUCTION: 75 PSIG nominal maximum suction pressure

ROTATION: Clockwise only facing pump shaft.

DRIVE: Direct

FILTRATION: 100 Mesh minimum recommended

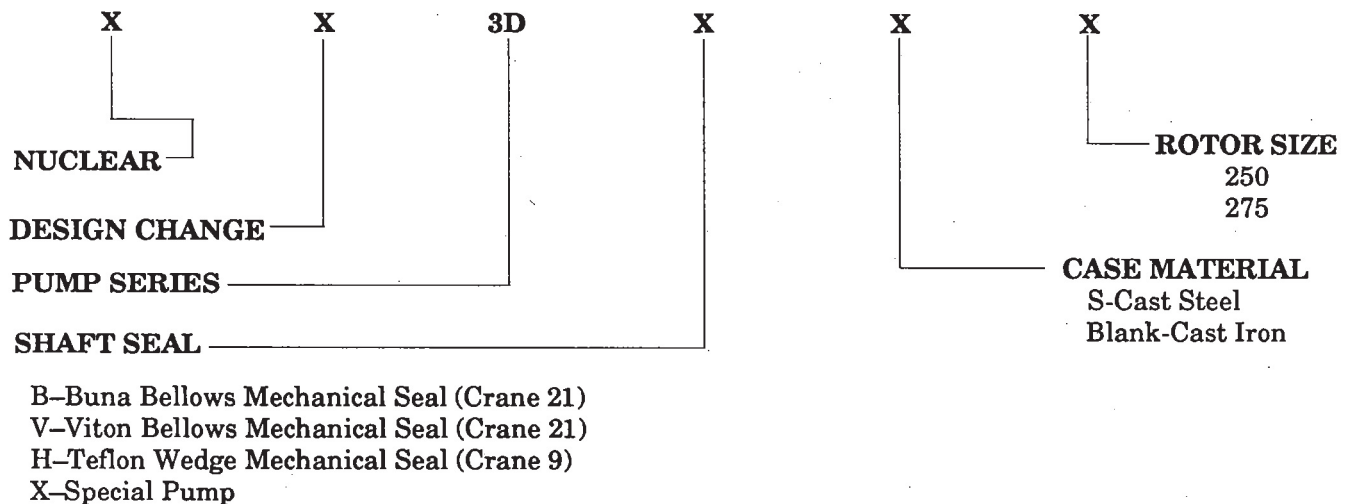

FIGURE 1. Definition of Model Designator of N3D Series Pumps.

DESCRIPTION

The N3D IMO Pump has only three moving parts, one power rotor and two idlers, which operate inside the rotor housing.

Fluid entering the pump suction inlet flows to the end of the rotors. At the rotor ends it enters the rotor set and the smooth intermeshing of these rotors propels the fluid axially in a smooth continuous flow, without churning, pocketing or pulsating action, to the discharge chamber where the fluid leaves the pump.

N3D Pumps are equipped with mechanical seals. Fluid being pumped is supplied to the seals through the clearance between the balance piston on the power rotor and the inboard cover. Entering fluid lubricates and cools the mechanical seal and is then returned internally back to the pump suction.

Two types of seals are installed in N3D Pumps. Pump designator B and V identifies a Crane 21 type seal illustrated in Figure 2. Designator H identifies a Crane 9 type seal and is illustrated in Figure 3.

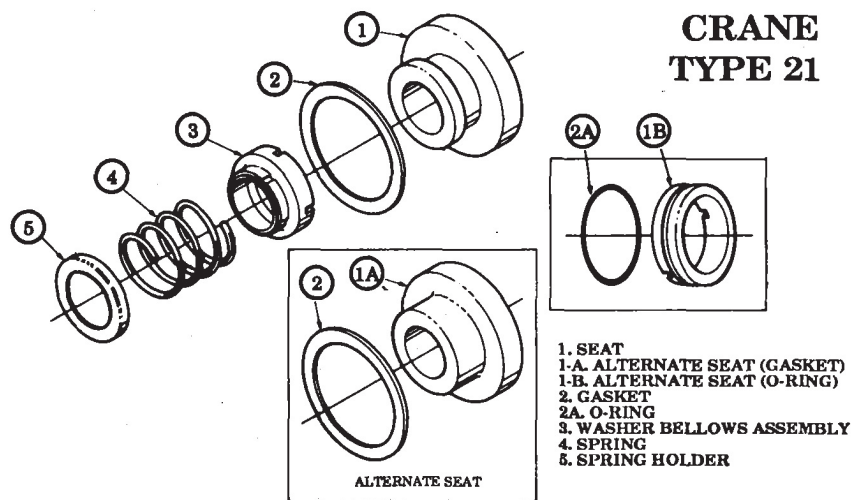

FIGURE 2. Crane Type 21 Seal

CRANE TYPE 9

- 1. SEAT
- 1-A. ALTERNATE SEAT
- 2. GASKET
- 2A. O-RING
- 3. SNAP RING
- 4. WASHER
- 5. CHEMLON RING
- 6. DISC
- 7. RETAINER
- 8. SET SCREW
- 9. SPRING
- 10. RETAINING CLIP

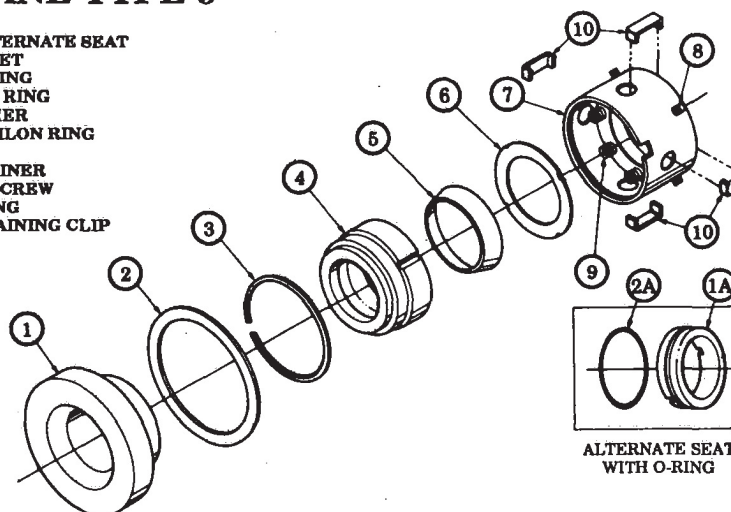

FIGURE 3. Crane Type 9 Seal

MAINTENANCE

PUMP DISASSEMBLY

NOTE

Refer to applicable pump drawing and parts list during pump disassembly and assembly. Obtain pump type from the nameplate then refer to Table 1 to identify applicable Assembly Drawing number and Figure number.

GENERAL: Close the inlet and outlet valves, lock and tag "Out of Service." De-energize pump driver motor controller and tag "Out of Service." Vent all pressure from pump case. Disconnect coupling and remove pump from driver and coupling hub from pump. Remove coupling key (016).

FIGURE 4 PUMP DISASSEMBLY

Remove bolts (010) and cover (026) with O-ring (008). Remove bolts (023) and lockwasher (024). Removal of bolt (023) will remove thrust plate (021) and spacers (022). Slide idlers (019) from pump housing (002).

NOTE

Rotate idlers (019) when removing from housing (002).

Remove bolt (018) and retainer (017). Pull power rotor (011) from cover (009). Removal of power rotor will include removal of truarc rings (013 and 035), ball bearing (015), spacer (014), and the mechanical seal (025).

Remove truarc ring (013) nearest key slot in power rotor (011). Using a bearing puller or bench press, remove ball bearing (015). Remove remaining truarc ring (013), spacer (014) mechanical seal (025) and truarc ring (035) from power rotor (011).

Remove inboard cover (009) by removing bolts (010) and pulling cover from case. Remove O-ring (007) from cover. Remove spacer (027). Remove O-ring (005) from tube pin located in inboard cover (009).

NOTE

Tube (004) is installed in inboard cover (009) using Loctite hardening compound and should not be removed as it is not serviced separately from inboard cover (009).

Remove mechanical seal (025) seat gasket from inboard cover (009) mechanical seal bore. Remove spirolox ring (052) from pump case (001).

Slide housing (002) from case. Housing (002) is removed by pushing from inboard end of pump and pulling housing out the inlet end of case. Remove O-ring (006) from housing (002).

FIGURES 5 AND 6 PUMP DISASSEMBLY

Remove bolts (010), cover (026) and gasket (098). Remove truarc ring (052) and slide cage (088) from case (001). Slide idler balance piston housing (020) from each idler (019). Rotate idlers (019) and pull each idler (019) from housing (002).

Remove bolts (018) and retainer (017). Remove power rotor (011) from housing (002) by pulling power rotor (011). Removal of power rotor (011) will include removal of truarc rings (013), ball bearing (015), spacer (014), mechanical seal (025) and sleeve (089).

Remove truarc ring (013) nearest key slot in power rotor (011). Using a bearing puller or bench press, remove ball bearing (015). Remove remaining truarc ring (013) and slide spacer (014), mechanical seal (025) and sleeve (089) from power rotor. Remove gasket from mechanical seal bore of cover (009).

Remove bolts (010), inboard cover (009) and gasket (098). Pull balance piston housing (094) from case (001). Remove O-ring (006) from balance piston housing (094) and O-ring (005) from tube located in balance piston housing (094).

NOTE

Tube is installed in balance piston housing (094) using Loctite hardening compound and should not be removed as it is not serviced separately from housing.

Remove stop pin (097) with Dyna-seal (096) from case (001) and housing (002). Push housing (002) out of case (001) in outboard end direction. Remove tube (004) from either housing (002) or cage (088). Remove O-rings (005) from tube (004). Remove O-ring (006) from housing (002).

NB3DVS-275 Pump only: Remove truarc ring (068), spacer (067) with O-ring (066) and check valve (065) with O-ring (064) from case (001). **NOTE:** Check valve (065) is replaced as a unit and is not serviced separately.

PUMP ASSEMBLY

NOTE

Assembly steps are outlined in paragraph form in the correct assembly procedure. All steps are to be followed in the outlined sequence unless a specific pump Figure is identified. When a specific Figure number is identified, the procedure is applicable only to the pumps identified by the Figure number. Refer to Table 1 for the Series N3D pump assembly and Figure number for your specific pump model.

GENERAL: Inspect, clean and wipe all bolts and internal or rotating parts with light lubricating oil immediately before assembly. Do Not open seal on bearing packages until they are to be installed. A new mechanical seal should be installed if the old seal has been disturbed. A new bearing should be installed when a seal is replaced or if unit has been in operation for an extended length of time. Replace all O-rings. Rotate the power rotor (011) frequently during installation to assure freedom of rotation.

FIGURE 4 PUMP ASSEMBLY

Coat case (001) and housing bores with oil. Install O-ring (006) in O-ring groove in housing (002). Slide housing (002) in case (001) with rotor bores in a horizontal plan. Install Spirolox ring (052) in case (001).

Slide spacer (027) over tube and install O-ring (005) on tube located in inboard cover (009). Coat all machined surfaces of inboard cover (009) with oil. Slide O-ring (007) on inboard cover (009). Align inboard cover (009) and tube with tube bore of housing (002) and bolt holes in case (001). Slide inboard cover (009) in case (001) and install bolts (010). Torque bolts (010) to 70 ft. lbs. (± 5 ft. lbs.). If plug (003) was removed during disassembly install same.

Assemble power rotor (011) as follows:

N3DBS-250 Pump only (Crane Type 21 Seal). Install truarc ring (035) on power rotor. Slide mechanical seal (025) rotating parts (3, 4 and 5, Figure 2) and seat (1, Figure 2) on power rotor with spring holder (5, Figure 2) next to installed truarc ring (035). Slide spacer (014) on power rotor (011) and install truarc ring (013) in ring groove furthest from power rotor (011) key slot. Install ball bearing (015) on power rotor (011) by pressing only on inner race of bearing, using a sleeve. Install truarc ring (013) next to ball bearing in ring groove of power rotor (011).

N3DHS-250 Pump only (Crane Type 9 Seal). Install truarc ring (035) on power rotor (011). Slide mechanical seal (025) rotating parts (3 through 10, Figure 3) and seat (1, Figure 3) on power rotor (011). With seal retainer (7, Figure 3) next to truarc ring (035), tighten set screws (8, Figure 3). Remove and discard retaining clips (10, Figure 3). Slide spacer (014) on power rotor (011) and install truarc ring (013) in ring groove furthest from power rotor (011) key slot. Install ball bearing (015) on power rotor (011) by pressing

only on inner race of bearing using a sleeve. Install truarc ring (013) next to ball bearing in ring groove of power rotor (011).

Install gasket (2, Figure 2 or Figure 3) in seal bore of inboard cover (009). Slide assembled power rotor (011) in inboard cover (009) centering each part as it enters. Align retainer (017) with bolt holes in inboard cover (009) and install with bolts (018). Torque bolts (018) to 20 ft. lbs. (± 2 ft. lbs.).

Coat idlers (019) with oil and rotate while installing each idler (019) in housing (002) rotor bores. Slide lock washers (024), thrust block (021) and spacer (022) over bolts (023). Install bolt assembly in housing and torque bolts (023) to 15 ft. lbs. (± 2 ft. lbs.)

Install O-ring (008) in O-ring groove of cover (026). Install cover (026) on case (001) with bolts (010). Torque bolts (010) to 70 ft. lbs. (± 5 ft. lbs.).

FIGURES 5 AND 6 PUMP ASSEMBLY

Coat case (001) and housing (002) bores with oil. Slide O-ring (006) in housing O-ring groove. Slide housing (002) in case (001) and align stop pin groove with stop pin bore of case. Install stop pin (097) with Dyna-Seal (096) in case (001) and housing (002).

Coat balance piston housing (094) with oil and install O-ring (006) in balance piston housing (094) O-ring groove. Slide O-ring (005) on tube fitted in balance piston housing (094) and slide balance piston housing (094) in case (001).

Align gasket (098) and inboard cover (009) bolt holes with case (001) bolt holes. Install gasket (098) and inboard cover (009) on case using bolts (010). Torque bolts (010) to 70 ft. lbs. (± 5 ft. lbs.).

Coat power rotor (011) with oil. Slide sleeve (089) on power rotor (011). Slide rotating parts (3, 4 and 5, Figure 2) and seat (1, Figure 2) of mechanical seal (025) on power rotor (011) with spring holder (5, Figure 2) next to sleeve (089). Slide spacer (014) on power rotor (011) and install truarc ring (013) in ring groove of power rotor (011) furthest from key slot. Install ball bearing (015) on power rotor (011) by pressing only on inner race of bearing using a sleeve. Install remaining truarc ring (013) on power rotor (011) next to bearing (015).

Install gasket (2, Figure 2) in seal bore of inboard cover (009). Slide assembled power rotor (011) in inboard cover and housing centering each part as it enters the pump. Align retainer (017) bolt holes and install using bolts (018). Torque bolts (018) to 24 ft. lbs. (± 2 ft. lbs.).

Rotate while sliding idlers (019) in housing (002) idler bores. Coat with oil and slide an idler balance piston housing (020) on each idler. Align cage (088) to receive tube (004) and slide cage (088) in case (001). Install truarc ring (052) in ring groove of case (001).

Align gasket (098) and cover (026) bolt holes with case (001) and install using bolts (010). Torque bolts (010) to 70 ft. lbs. (± 5 ft. lbs.).

NB3DVS-275 Pump only. Coat check valve (065) with oil and install O-ring (064) on check valve. Slide check valve (065) in case (001). Coat spacer (067) with oil and slide O-ring (066) in ring groove of spacer (067). Slide spacer (067) in case (001) and install truarc ring (068).

**PARTS LIST
FIGURE 4 PUMPS**

ITEM	PART DESCRIPTION	ITEM	PART DESCRIPTION
001	Case	019 (2)	Idler Subassembly
002 (2)	Housing		(includes items 020 and 054) (2)
003	Plug 1/4 SHP	020 (3)	Idler Balance Piston Housing
004 (3)	Tube (part of item 009)		(part of item 019)
005 (1)	O-ring	021 (2)	Thrust Plate
006 (1)	O-ring	022	Spacer (2)
007 (1)	O-ring	023	Bolt 3/8 x 6 (2)
008 (1)	O-ring	024	Lockwasher 3/8 (2)
009	Inboard Cover Subassembly	025 (1)	Seal
	(includes items 004 and 034)	026	Cover
010	Bolt 3/4 x 1 3/4 (8)	027	Spacer
011 (2)	Power Rotor Subassembly	028	Name Plate
	(includes items 012 and 055)	029	Drive Screw U#6 x 1/4 (6)
012 (3)	Piston (part of item 011)	034 (3)	Inboard Cover
013 (1)	Truarc Ring (2)		(part of item 009)
014	Spacer	035 (1)	Truarc Ring
015 (1)	Ball Bearing	052 (2)	Spirolox Ring
016	Key	053	Name Plate
017	Retainer	054 (3)	Idler (part of item 019)
018	bolt 1/2 x 1 1/4 (4)	055 (3)	Power Rotor
			(part of item 011)

NOTES:

- (1) Items required for Minor Repair kit
- (2) Items required for Major Repair kit (includes (1) item)
- (3) Not serviced separately. All quantities are one except when noted in parentheses after part description.

SPECIAL NOTE:

The IMO Pump Division recommends that repair parts be ordered by Minor or Major Repair kit. When ordering kit, identify Minor or Major repair, pump model and serial number.

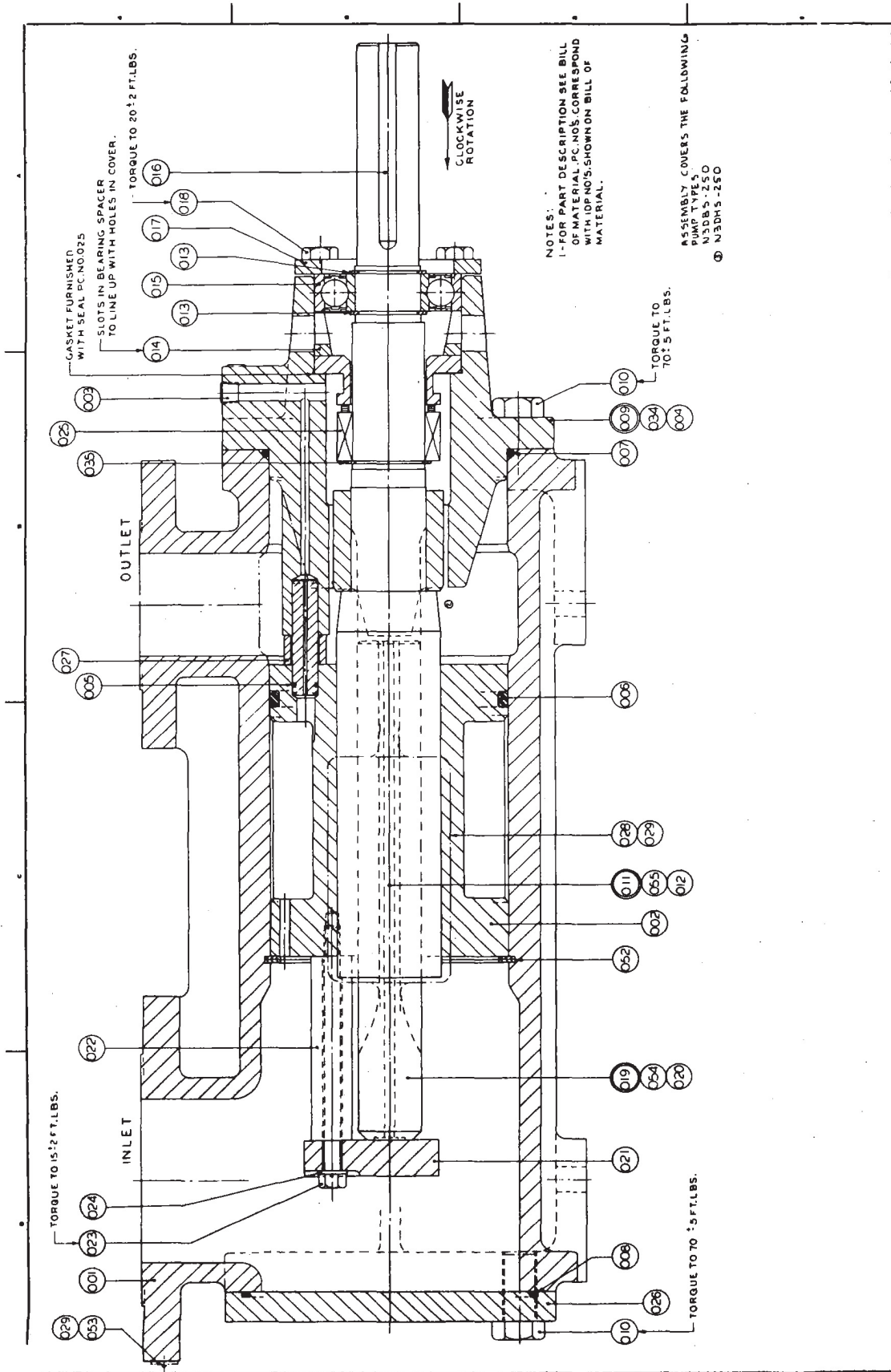

NOTES:
 1- FOR PART DESCRIPTION SEE BILL OF MATERIAL. P.C. NOS. CORRESPOND WITH P.C. NOS. SHOWN ON BILL OF MATERIAL.
 ASSEMBLY COVERS THE FOLLOWING PUMP TYPES:
 N3DB5-250
 N3DB5-250
 N3DB5-250

FIGURE 4. Pump Assembly Drawing SD-5546

**PARTS LIST
FIGURES 5 AND 6 PUMPS**

ITEM	PART DESCRIPTION	ITEM	PART DESCRIPTION
001 (3)	Case Subassembly (includes items 035 through 038)	037 (4) (5)	Pipe (part of item 001)
002 (2)	Housing	038 (4) (5)	Elbow 90° SW 1 1/4 (part of item 001)
003	Plug 1/4 SHP	052 (2)	Truarc Ring
004	Tube	053	Name Plate (Suction)
005 (1)	O-ring (3)	058	Name Plate (Rotation)
006 (1)	O-ring (2)	064 (1) (4)	O-ring
009	Inboard Cover	065 (2) (4)	Check Valve
010	Bolt 5/8 x 1 1/2 (16)	066 (1) (4)	O-ring
011 (2)	Power Rotor Subassembly (includes items 033 and 099)	067 (4)	Spacer
013 (1)	Truarc Ring	068 (2) (4)	Truarc Ring
014	Spacer	088 (2)	Cage Subassembly (includes items 034 and 095)
015 (1)	Ball Bearing	089	Sleeve
016	Key	090	Cap Plug #53
017	Retainer	091	Cap Plug #1063
018	Bolt 5/8 x 1 1/4 (4)	092 (5)	Tube (part of item 094)
019 (2)	Idler (2)	093 (5)	Balance Piston Housing (part of item 094)
020 (2)	Idler Balance Piston Housing (2)	094 (2)	Balance Piston Housing Subassembly (includes items 092 and 093)
025 (1)	Seal	095 (5)	Drive Screw U #10 x 3/8 (part of item 088) (2)
026	Cover	096 (1)	Dyna-Seal
028	Name Plate (Serial)	097 (2)	Stop Pin
029	Drive Screw U#6 x 1/4 (8)	098 (1)	Gasket 0.015 (2)
033 (5)	Power Rotor (part of item 011)	099 (5)	Piston (part of item 011)
034 (5)	Cage (part of item 088)		
035 (4) (5)	Case		
036 (4) (5)	Valve Body (part of item 001)		

NOTES:

- (1) Items required for Minor Repair kit
- (2) Items required for Major Repair kit (includes (1) item)
- (3) NA3DVS-275 pump item 001 description in case only
- (4) NB3DVS-275 pump only
- (5) Not serviced separately

All quantities are one except when noted in parentheses after part description.

SPECIAL NOTE:

The IMO Pump Division recommends that repair parts be ordered by Minor or Major Repair kit. When ordering kit, identify Minor or Major repair, pump model and serial number.

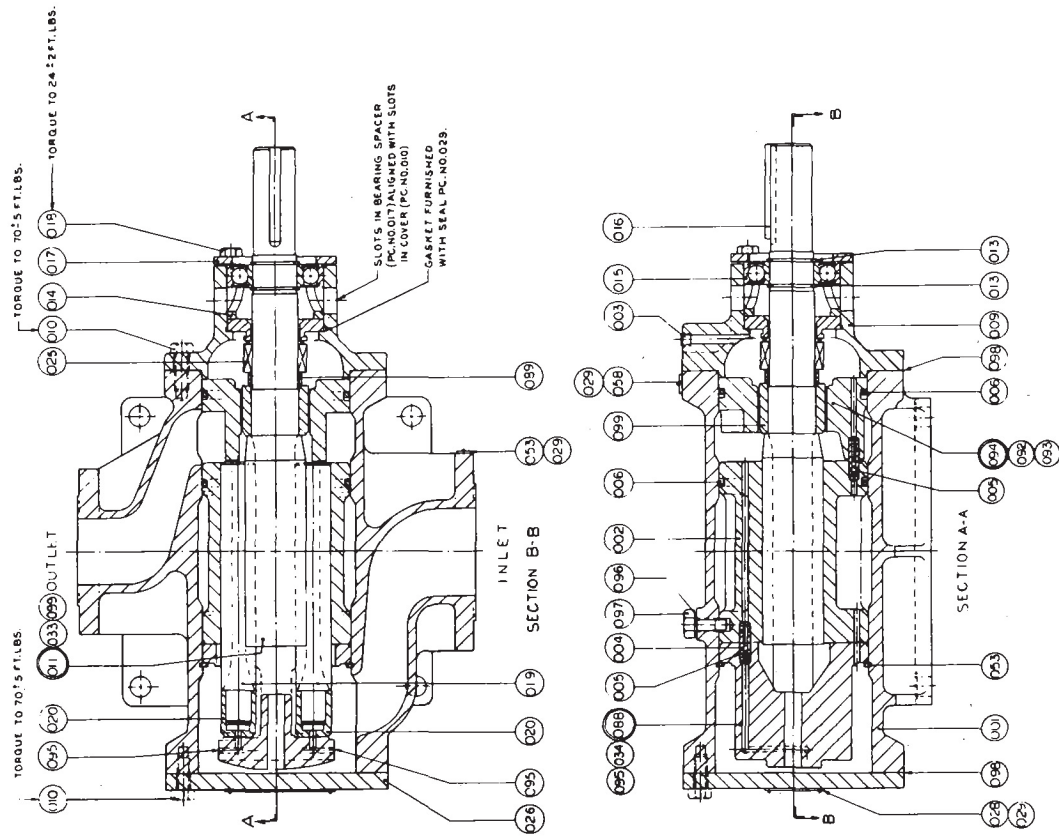

NOTES:
 1. BALANCE EYESTON, PC NO. 089 NOT SERVICED SEPARATELY FURNISHED AS PART OF POWER ROTOR SUB-ASSEMBLY PC NO. 011 CONSISTING OF (1) EACH PC NO. 083 AND 088.
 2. FOR PART DESCRIPTION SEE STD. OR PURPOSE BILL OF MATERIAL PART NOS. CORRESPOND WITH DFE NOS. SHOWN ON BILL OF MATERIAL.

PUMP WEIGHT 336 LBS. (EST.)

NA3DVS-275

FIGURE 5. Pump Assembly Drawing SF-5633

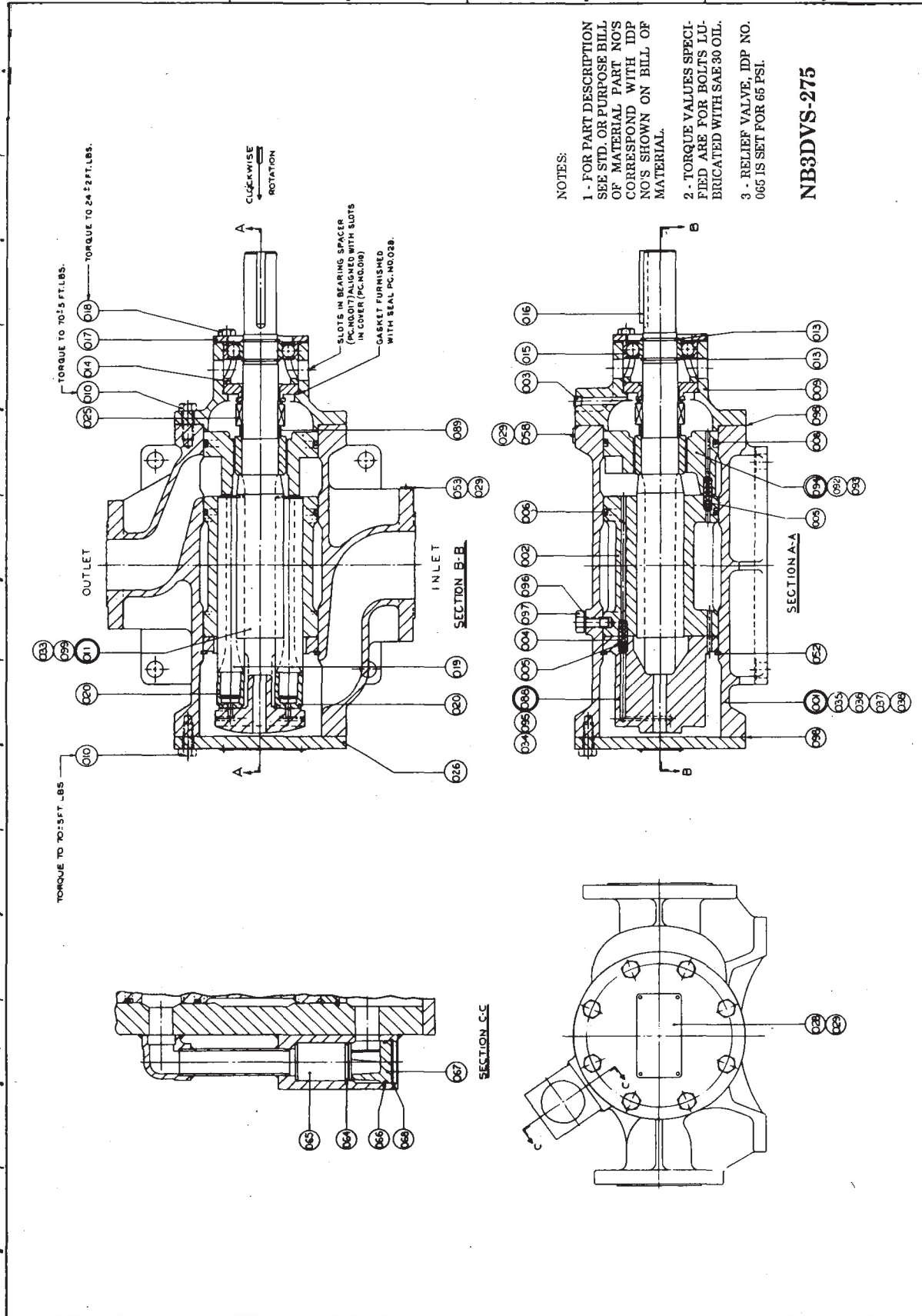

- NOTES:
- 1 - FOR PART DESCRIPTION SEE STD. OR PURPOSE BILL OF MATERIAL PART NOS CORRESPOND WITH IDP NO'S SHOWN ON BILL OF MATERIAL.
 - 2 - TORQUE VALUES SPECIFIED ARE FOR BOLTS LUBRICATED WITH SAE 30 OIL.
 - 3 - RELIEF VALVE, IDP NO. 065 IS SET FOR 65 PSI.

NB3DVS-275

FIGURE 6. Pump Assembly Drawing SF-5704

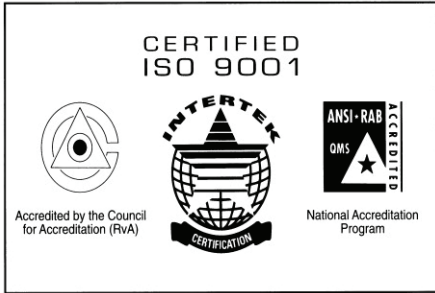

CIRCOR

1710 Airport Road
PO Box 5020
Monroe, NC USA
28111.5020

Tel: +1. 877.853.7867

Email: cc@circor.com

Web: www.circorpt.com

