

# Imo Series 8L Pump: Product Enhancement

## Colfacts

Colfax Americas

Imo Pump introduces the "GLH" upgrade for the installed base of 8L pumps. Effective January 1st 2007, Imo will exclusively quote and supply only "GLH" version repair kits for the 8L series product line. For field conversion of existing 8L series pumps, Imo will supply a modification kit that will allow the user to upgrade to the "GLH" design. Purchase of the mod kit is a one time occurrence and will require the installation of a "GLH" major repair kit during overhaul.

The "GLH" upgrade enhances the hydraulic thrust arrangement with a combination of design modifications to the idler rotors, rotor housings and thrust plate. This will result in extending the performance of a pump line that has proven itself with over two decades of successful experience in fuel experience in crude oil and fuel applications worldwide.

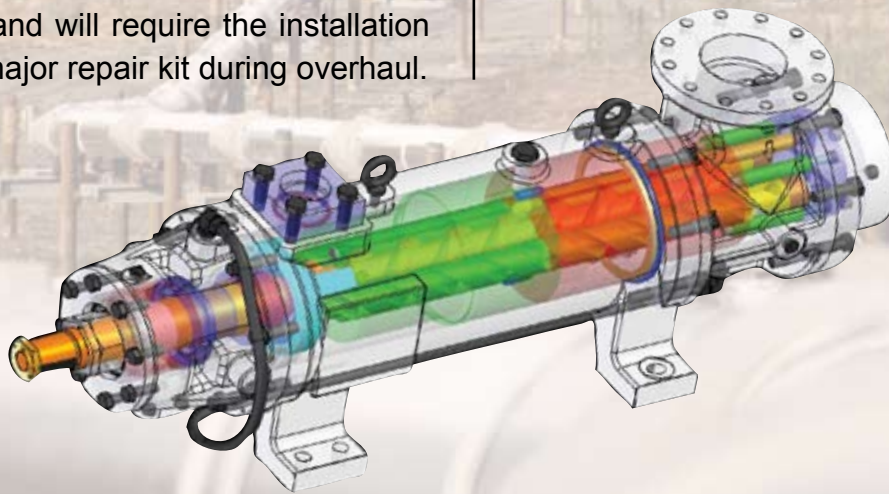

### Installation Location:

Western Canada

### Pump Model:

GLH8LDDT-462

### Rotating Speed:

1150

### System Pressure:

1400 psig

### Flow Rate:

420 gpm

### Fluid:

Crude Oil



**Colfax**  
Corporation



© 2007 Colfax Corporation  
All Rights Reserved  
COLFACT 8L-01/07

# Imo Series 8L Pump: Product Enhancement

## Colfacts

Colfax Americas

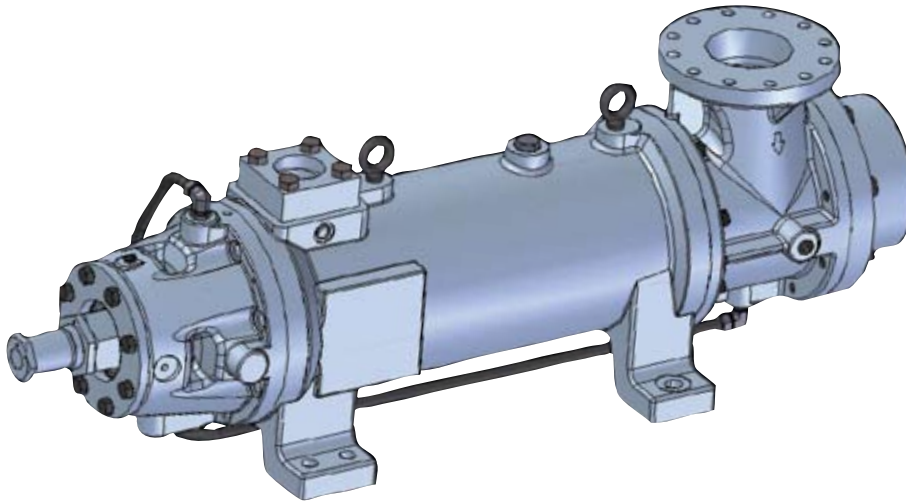

### Series GLH8L Operating Capabilities:

- Flow rates to 40,000 bbls/day (1170 gpm)
  - Crude Oil viscosities from 60 ssu
- Standard pump discharge pressures to 1500 psig.  
Higher pressures available on special units.

#### Colfax Americas

PO Box 5020 (28111-5020)  
1710 Airport Road  
Monroe, NC 28110 USA  
Phone: 704-289-6511  
Fax: 704-289-9273  
E-mail: [imo.pump@colfaxcorp.com](mailto:imo.pump@colfaxcorp.com)  
Internet: [www.imopump.com](http://www.imopump.com)



© 2007 Colfax Corporation  
All Rights Reserved  
COLFACT 8L-01/07