



## Smart Sense Intelligent Pump Control System

Know what's going on inside your pumping system.



You've come to expect precision, long life and maximum energy efficiency from Imo, Allweiler, Houttuin, Warren and other Colfax Americas pump solutions.

Now you can monitor your fluid transfer system performance, adjust to changing conditions and order its own replacement parts - all without human supervision. The Smart Sense intelligent pump control system assures continual, precision pumping performance in applications where minimizing downtime and maximizing pump life is critical.

The Colfax Smart Sense System continually monitors a host of sensors on your pump system including temperature, pressure, wear, cavitation, and integrity of the mechanical seal. Based on the condition of the pump, the system controls pump parameters to maximize system performance. It can operate by itself at a remote pumping location or be connected to a network of pumps managed at a central office.

Colfax software includes a preventive maintenance calendar and - based on foreseen needs or detected problems - the ability to determine which parts need to be replaced, and even as an option, automatically issuing a purchase order for them. The software also maintains precise records in an electronic log book that operators can use to track performance trends over time.

Smart Sense gives you the performance edge you demand:

### Precise flow control, optimization and measurement which delivers:

- Reduced energy consumption;
- Lower energy costs.

### Condition based monitoring systems that enable:

- Minimal maintenance stops/down time;
- Reduced maintenance costs;
- System diagnosis;
- Increased efficiency of system.

### Remote operation and maintenance monitoring for:

- Reduced costs for on-site supervision and maintenance;
- Greatly increased personnel safety.



Built in monitoring and process control for your mission critical applications

- **Gather real-time operational data**
  - Determines the operational envelope of your pump.
  - Maximizes pipeline throughput efficiency.
  - Automatically adjusts flow rate to prescribed levels.
- **Report operational trends**
  - Determine output performance, volumetric and overall efficiency.
  - Schedule service events.
  - Maintain operational effectiveness.
- **Remote monitoring, warnings, and alarms**
  - Understand performance parameters and performance trends.
  - Measure pump wear, shaft seal leaks.
  - Monitor upset conditions, such as cavitation.



### Smart Sense Overview

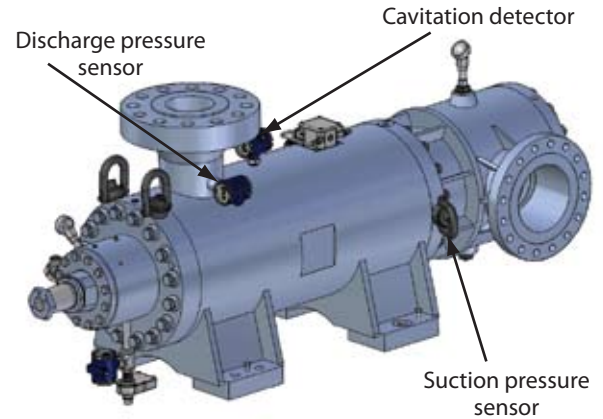

### Power Rotor Bore Cutaway

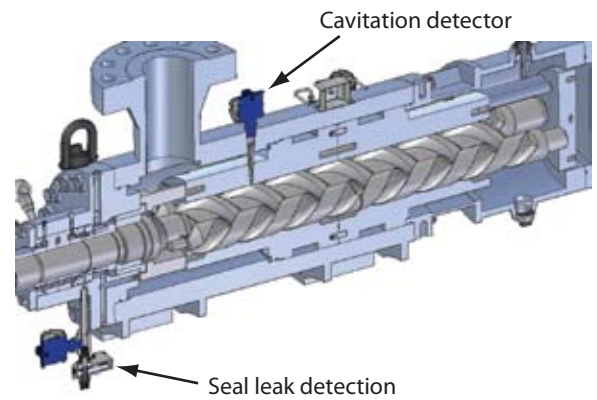

### Idle Rotor Bore Cutaway

