



INSTRUCTIONS and PARTS LIST

SERIES 6LB

WARNING

**READ THIS INSTRUCTION BOOK AND CA-1 BEFORE
INSTALLATION, OPERATION OR MAINTENANCE**

Instructions 6LB (R-4)

This manual now is
identified as part no.
SRM00028

**Imo Delaval Inc.
IMO Pump Division
P.O. Box 5020
Airport Road
Monro , NC 28110-0527
USA**

June 1987

FOREWORD

This manual covers all basic models of the 6LB Series Pumps. The model of a particular pump may be found on the nameplate. Basic types of 6LB pumps are identified as follows:

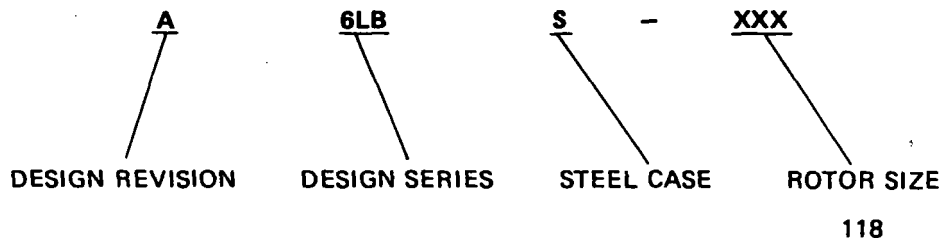

118

The shaft seal of the 6LB series pumps consists of a Viton bellows mechanical face type seal (carbon face on an iron seat).

SPECIAL INSTALLATION INSTRUCTIONS

Mounting

CAUTION

When the inlet head is turned, care must be taken to keep the thrust plate in original position to maintain oil flow to rear of idlers.

OPERATIONAL SAFETY PRECAUTIONS

Structural Limits

Operating conditions, such as speed, fluid viscosity, inlet pressure, discharge pressure, temperature, filtration, duty cycle, mounting, drive type, etc. are interrelated. Due to these variable conditions, the specific application limitation may be different from that of the structural limitations. This equipment must not be operated without verification that operating requirements are within published capabilities as shown in the appropriate pump data book (available from local IMO Pump Division offices and representatives).

Under no circumstances are the following structural limitations to be exceeded.

Maximum Discharge Pressure – 2000 PSIG

Maximum Inlet Pressure – 100 PSIG @ 3600 RPM or less

Maximum Fluid Temperature – 160°F

DISASSEMBLY & ASSEMBLY PROCEDURES

Disassembly of Pump

Step 1 — Remove outboard end cover (035) and thrust plate (036). Separate these parts by removing cap screws (041). Remove "O" rings (013 and 018).

Step 2 — Remove inlet head (020) and laminated shim (004) by first removing cap screws (037) and lock washer (054).

Step 3 — Remove cups (033) from idler rotors (032). Screw idler rotors out along with shoes (034) which are pressed on at assembly.

Step 4 — Remove bearing retainer (028). Remove power rotor (022) from inboard end together with mechanical seal (023), bearing spacer (025), retaining ring (024), ball bearing (027), lockwasher (031) and locknut (030). This assembly may be left intact unless it is necessary to service either the mechanical seal or ball bearing. If they are to be left assembled, wrap carefully to protect from dirt and damage and proceed to step 5. For disassembly instructions refer to page 4.

Step 5 — Remove inboard end cover (011) with "O" ring (006), backup ring (005), bushing (014), idler stop (016) and snap ring (055). Remove "O" ring (018) from groove in case. To remove bushing (014), first remove snap ring (055) and idler stop (016).

Housing bores and rotors may be examined at this time. If it is necessary to remove rotor housing (003), proceed as follows:

Step 6 — Remove plug (010) and "O" ring (009). Remove housing stop pin (008) using 1/4" — 20 tapped hole provided for that purpose.

Step 7 — Push housing (003) with "O" ring (006) and backup ring (005) out of inboard end of pump case (001).

R assembly of Pump

Inspect and clean all parts before starting reassembly. New "O" rings, gaskets and seals should be installed whenever the pump is built. Light lubricating oil should be used to assist pump reassembly. DO NOT USE GREASE.

Step 1 — Install new "O" ring (006) and backup ring (005) into groove on rotor housing (003). Backup ring is located toward outboard end of pump when housing is installed.

Step 2 — Apply light coat of oil to housing and insert into pump case (001) from outboard end until stop pin slot is aligned with hole in case. Install rotor housing stop pin (008) making sure it is properly seated in slot. Install plug (010) and "O" ring (009) on top of stop pin.

Step 3 — Install bushing (014) into inboard end cover (011). Install idler stop (016) and snap ring (055).

Step 4 — Install new "O" ring (006) and backup ring (005) into groove on inboard end cover (011). Backup ring should be toward inboard end of pump when cover is assembled on case. Install "O" ring (018) in groove in case. Apply a light coat of oil and slide cover into case making sure that discharge hole is aligned with discharge opening of case. Fasten cover to case with eight capscrews (017).

Step 5 – Assembly of the power rotor will be covered on page 5. If power rotor assembly did not require servicing proceed with step 6.

Step 6 – Insert gasket furnished with the mechanical seal into counterbore of the end cover (011). Apply a light coat of oil to power rotor (022) and insert into case from inboard end. Bolt bearing retainer (028) to cover with four hex head bolts (029).

Step 7 – Insert idler rotors (032) into housing and install cups (033) over the shoes (034) which are pressed on at assembly.

Step 8 – Make sure the rotor housing (003) is pushed tightly against the inboard end of the pump case (001). Measure the distance from the outboard face of the pump case to the housing. Install the laminated shim (004) to give .005"/.015" clearance from the face of the case to the laminated shim (004).

Step 9 – Install new "O" rings (012 and 018) into grooves on the outboard face of the pump case (001). Bolt the inlet head (020) to the case in desired position. Secure with lockwashers (054) and capscrews (037).

Step 10 – Install new "O" rings (013 and 018) into grooves on outboard end cover (035) and bolt the cover to the inlet head (020) with eight capscrews (038) and Dyna Seals (039). Make sure the thrust plate (036) which is bolted to the cover, is properly aligned so that the two oil holes are in line with the idler rotors (032).

The inlet head (020) position may be changed but care must be taken that the thrust plate (036) is in the correct position.

NOTE: Name plate arrow (052) on cover (035) must align with the name plate arrow (052) on case (001) for proper cover position.

Step 11 – Check that the rotors turn freely in place before installing the pump.

Reinstall the pump in accordance with instructions given in Instruction Manual CA-1. Check section dealing with "OPERATION" when putting pump back into service.



Figure 1

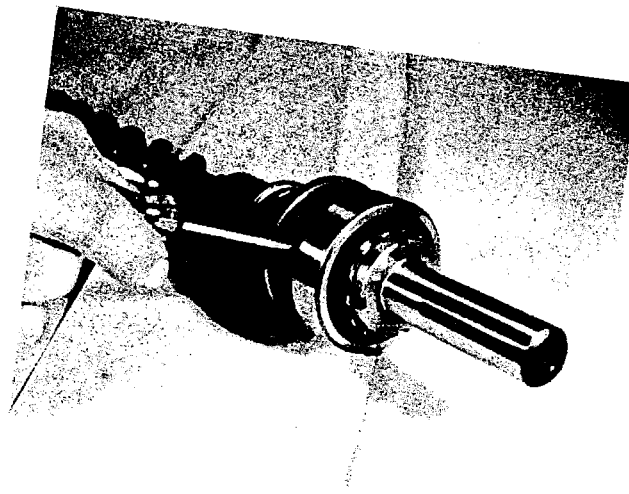

Figure 2

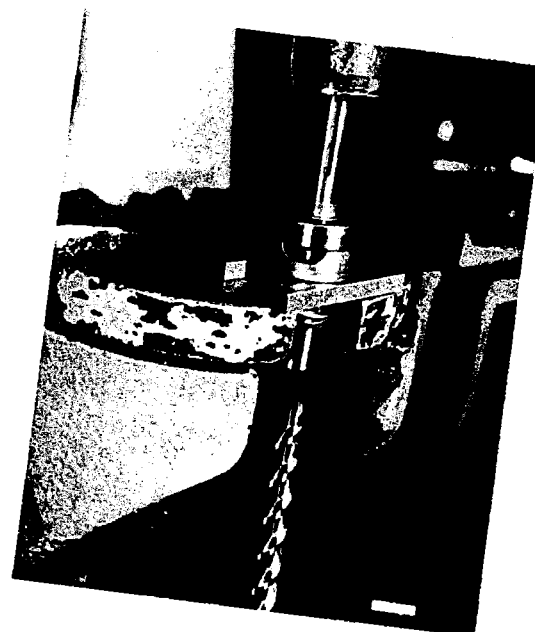

Figure 3

**Disassembly
Bearing and Type 21 Mechanical Shaft Seal**

- Step**
1. If it is still in place, remove the coupling hub from the drive shaft.
 2. Remove locknut and lockwasher with a spanner wrench. (fig. 1)
 3. Remove inner snap ring by prying with a screw driver thru the bearing space (fig. 2).
 4. Insert the power rotor assembly into a press and press off the bearing, bearing spacer, and stationary seat of the mechanical seal. (fig. 3)
 5. Remove seal subassembly from under the stationary seat.
 6. Inspect the shaft. If the shaft is pitted or badly scratched or the retaining ring grooves damaged, replace the power rotor.
 7. Discard the old seal, bearing and retaining rings.

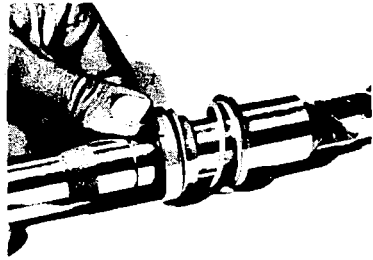

Figure 4

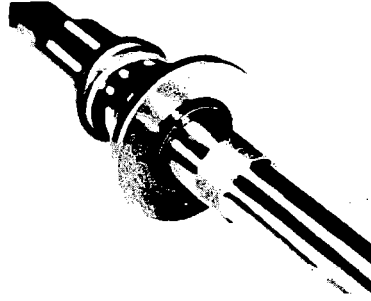

Figure 5

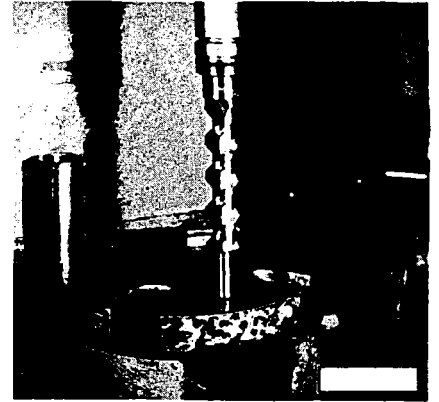

Figure 6

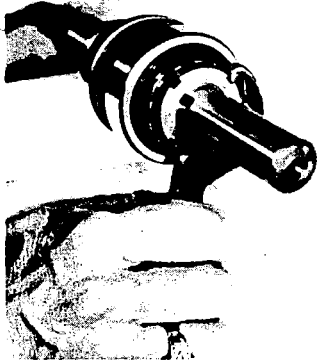

Figure 7

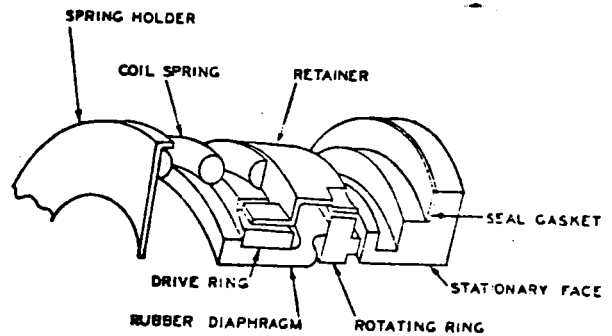

Figure 8

**Assembly
Bearing and Type 21 Mechanical Shaft Seal**

Step

1. Clean the power rotor shaft and snap ring grooves prior to installing the new seal, bearing and retaining rings.
2. Lubricate the shaft with clean hydraulic fluid.
3. Place the spring holder and spring on the shaft.
4. Using a rotating motion gently slide the seal subassembly over the shaft (fig. 4). Use care not to cut the flexible diaphragm and drive ring. A piece of shim stock wrapped around the power rotor shaft to cover the snap ring grooves and shoulder of the seal diameter may be used for the purpose. If shim stock is used, twist the seal subassembly in the same direction as the wrap of the shim stock when installing it.
5. Lubricate the face of the carbon ring in the mechanical seal and place the stationary seat on the power rotor. Install inner retaining ring (fig. 5).
6. Place the bearing spacer onto the shaft.
7. Place the ball bearing on the shaft. Using a hollow tube and pressing on the inner race, set the bearing firmly against the inner race (fig. 6). Do not press the bearing on the outer race.
8. Install lock washer and lock nut using a spanner wrench (fig. 7).
9. Reference fig. 8 for detailed drawing of Crane Type 21 Mechanical Shaft Seal.

PARTS LIST
 SERIES 6LB
 DRAWING SF-5430

Pt. No.	Name	Pt. No.	Name	Pt. No.	Name
001	Pump Case	024	Retaining Ring X	043	
003	Rotor Housing XX	025	Bearing Spacer	044	
004	Laminated Shim XX	026	Coupling Key	045	
005	Backup Ring X (2)	027	Ball Bearing X	046	
006	"O" Ring X (2)	028	Bearing Retainer	047	Inlet & Outlet
008	Rotor Housing Stop Pin XX	029	Hex Head Bolt (4)	048	Adapter Assemblies
009	"O" Ring X	030	Lock Nut XX	049	
010	Plug XX	031	Lock Washer XX	050	
011	Inboard End Cover	032	Idle Rotor XX (2)	051	Name Plate
012	"O" Ring X	033	Cup XX (2)	052	Name Plate
013	"O" Ring X	034	Idle Shoe	053	Rivet
014	Balance Piston Bushing XX	035	Outboard End Cover	054	Lockwasher
016	Idle Stop XX	036	Thrust Plate Sub-Assy. XX	055	Snap Ring XX
017	Cap Screw (8)		Includes Pt. 021	056	Idle Rotor Assy.
018	"O" Ring X (4)	037	Cap Screw (8)		consisting of Pts.
019	Soc. Head Pipe Plug (5)	038	Cap Screw (8)		032 & 034 XX (2)
020	Inlet Head	039	Dyna Seal X (8)	057	Name Plate (Rotation)
021	Soc. Head Pipe Plug	040	Washer (4)	058	Name Plate (Suction)
022	Power Rotor XX	041	Cap Screw (4)	062	Spacer
023	Mechanical Seal X	042	Soc. Head Pip Plug	063	Pin
				070	Gasket X

RECOMMENDED SPARE PARTS

All parts marked X make up a minor repair kit.

All parts marked X & XX make up a major repair kit.

Quantity is for one piece except as noted in parentheses.

57-5430

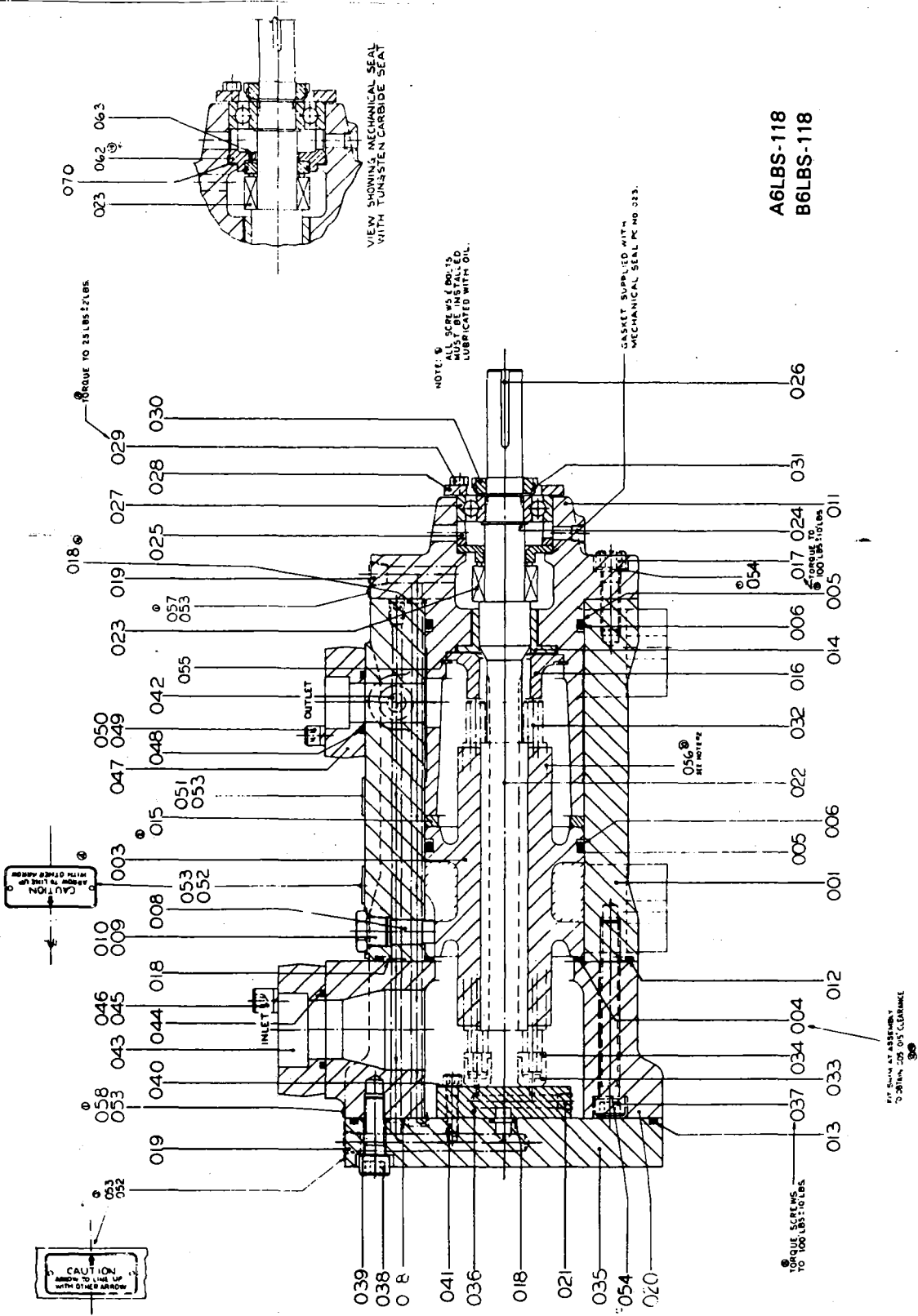

A6LBS-118
B6LBS-118

SERIES 6LBS PUMP DIMENSIONS

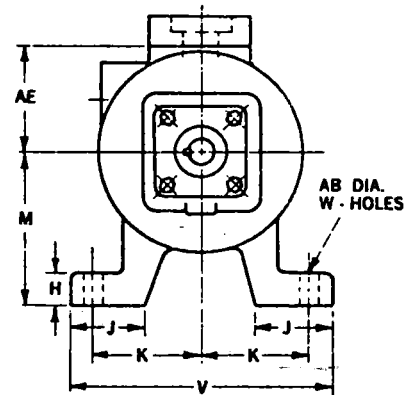
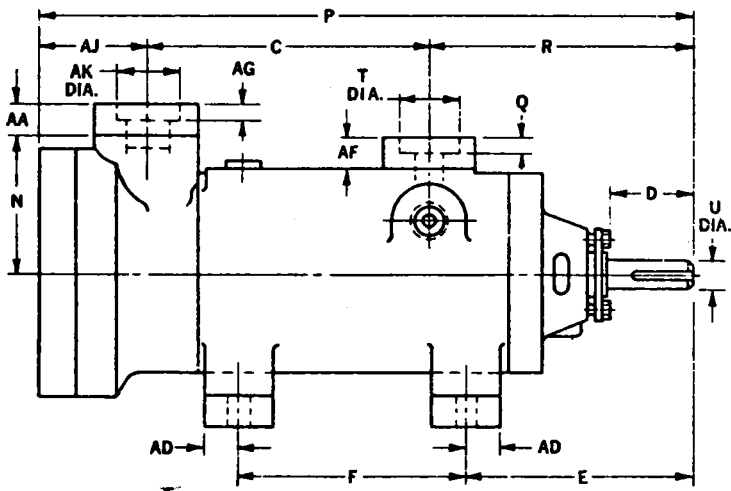
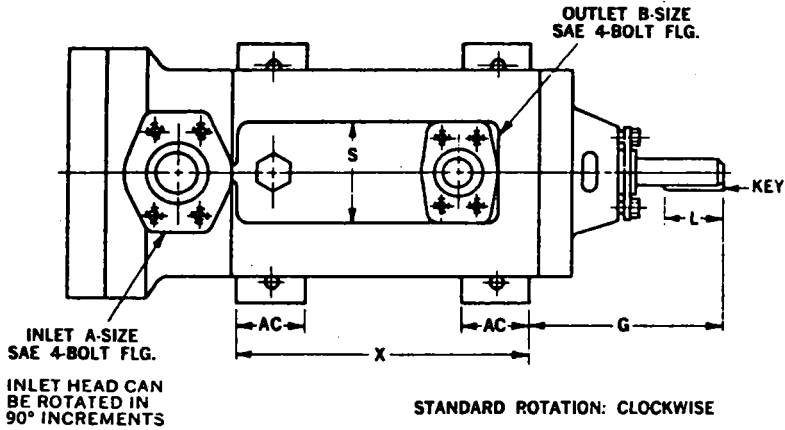

ALL DIMENSIONS ARE IN INCHES.

TYPE 6LBS	A	B	C	D	E	F	G	H	J	K	L	M	N	P	Q	R	S	T	WEIGHT LBS.
118	1 1/2	1	7 3/8	2 3/4	7 1/8	6	6 1/8	1	2 1/2	3 1/2	1 7/8	4	4 1/2	19 5/8	5/8	8 1/2	3 1/16	1 21/64	160
TYPE 6LBS	KEY		U	V	W	X	Z	AA	AB	AC	AD	AE	AF	AG	AH	AJ	AK	WEIGHT LBS.	
118	3/16 x 3/16		.8750 .8745	8 1/2	4	8	—	1 3/16	5/8	2 1/4	1	3 1/2	7/8	3/4	—	3 1/2	1 5/8	160	

NOTE #1: Dimensions "AK" and "T" are weld sockets (welds by customer).
NOTE #2: Top inlet position is standard.