



INSTRUCTIONAL MANUAL

Series C324A
ROTOR SIZES 275-300

WARNING

**READ THIS INSTRUCTION MANUAL AND CA-1 BEFORE
INSTALLATION, OPERATION, OR MAINTENANCE**

Instructions C324A-B (R-1)

This manual now is
identified as part no.
SRM00044

Imo Delaval Inc.
IMO Pump Division
P.O. Box 5020
Airport Road
Monroe, NC 28110-0527
USA

June 1987

The instructions given herein cover generally the operation and maintenance of subject equipment. Should any questions arise which may not be answered specifically by these instructions, they should be referred to the IMO Pump Division for further detailed information and technical assistance.

This manual cannot possibly cover every situation connected with the operation, adjustment, inspection, test, overhaul and maintenance of the equipment furnished. Every effort is made to prepare the text of the manual so that engineering and design data is transformed into the most easily understood wording. The IMO Pump Division, in furnishing this equipment and this manual, must presume that the operating and maintenance personnel assigned thereto have sufficient technical knowledge and experience to apply sound safety and operational practices which may not be otherwise covered herein.

In applications where the IMO Pump Division furnished equipment is to be integrated with a process or other machinery, these instructions should be thoroughly reviewed to determine the proper integration of the equipment into the overall plant operational procedures.

FOREWORD

This instruction manual covers Series C324A, rotor sizes 275 and 300, pumps. Because of the large number of operating conditions, it is necessary to have a variety of construction and material combinations to meet job requirements. The model of each pump is identified on the pump nameplate.

NOTE

This manual identifies pump types and sealing designs by figure numbers only. For maintenance, disassembly and re-assembly procedures, ensure that the specific pump type is identified with correct Figure Number(s). Refer to Table 1 and Figures 8 through 14 for proper identification of specific models.

Series C324A pumps are upgraded versions of the basic A324A and B324A designs. One of the product refinements of the C324A Series, rotor sizes 275 and 300, is the tapered design of the power rotor shaft. Initial designator A and B pump types are equipped with a 1° tapered power rotor. More recent C designator pumps are equipped with a 3/4-inch per foot taper on the power rotor shaft for ease of connecting and disconnecting coupling hubs. Table 1 identifies A and B pump type designators with corresponding C pump type designators. Definitions of model designators are given in Figure 1.

DESCRIPTION

The 324A series are positive displacement, rotary, screw-type pumps. Fluid entering the suction inlet divides and flows to the end of the rotors. At rotor ends, fluid enters the rotor set, and the smooth intermeshing of these rotors propels the fluid axially in a smooth flow, without churning, pocketing or pulsation to the central discharge chamber. The fluid entering from both ends keeps the rotors in axial hydraulic balance. The moving parts are lubricated by the fluid being pumped.

The basic C324A series pumps are supplied with an iron case and covers with packing. For special applications, pumps are supplied with a steel case and covers and/or with a steam jacketed case. Special high temperature packing or mechanical seals are used for high temperature applications.

Each model of this series is equipped with a seal piping connection between pump discharge and seal housing or packing gland. When the pump is operated with a suction lift, liquid under pressure is delivered to the pump-side of either the packing or mechanical seal, depending on pump type. On packing type pumps, air is prevented from leaking into the pump by a slow-flowing liquid seal. Flow control is regulated by a needle valve. The needle valve opening should be great enough to allow a slow leak of liquid past the packing while the pump is in operation and is pre-set for normal conditions before being shipped. As a precaution, the valve is slotted to avoid full closure.

SERIES 324A-424A INSTRUCTION MANUALS

Rotor Size	Instructions
162-250	C324A-424A-A
275-300	C324A-B
325-412	C324A-C
Double Extended	C324A-D

**TABLE 1
324A PUMP TYPES
ROTOR SIZES 275 AND 300**

INITIAL DESIGNATORS			PUMP FIG. NO.	SEALING DESIGN FIG. NO.	SEAL SEAT DESIGN FIG. NO.
A, B, BA SB or C	CB, CC CAB or CSB	C324A			
A324A	CB324A	C324APF	8	8	
A324AA	CB324AA	C324AHF	8	3 or 6 (2)	9 or 10 (3)
A324AS	CB324AS	C324BF	8	4 (2)	9 or 10 (3)
B324AS	CB324AS	C324ABF	8	4 (2)	9 or 10 (3)
	CB324AW	C324AEF	8	8	
A324AX	CB324AX (4)	C324AX (4)	8	8	
A324AAX	CB324AAS	C324AHFS	8	3 or 6 (2)	9 or 10 (3)
B324ASX	CB324AAS	C324AHFS	8	3 or 6 (2)	9 or 10 (3)
	CB324AFS	C324AXS (4)	8	11 (2)	11
	CB324AGX (4)	C324ARTFS	8	5 (2)	12
A324ASX	CB324ASS	C324ABFS	8	4 (2)	9 or 10 (3)
B324AWS	CB324AWS	C324AEFS	8	8	
A324AAXT	CB324AAST	C324AHTFS	8	3 or 6 (2)	9
A324ASXT	CB324ASST	C324ABTFS	8	4 (2)	9
C324A	CC324A	C324AX (4)	8	8	
A324A	CAB324A	C324APFJ	13	13	
A324AX	CAB324AX (4)	C324APFJ	13	13	
A324AAX	CAB324AAS	C324AHFJ	13	3 or 6 (2)	9 or 10 (3)
	CAB324ASS	C324ABFJ	13	4 (2)	9 or 10 (3)
BA324AWX	CAB324AWS	C324AEFJ	13	13	
	CAB324AAST	C324AHTFJ	13	3 or 6 (2)	9
	CSB324A	C324APFY	13	14	
	CSB324AX (4)	C324APFY	13	13	
SB324AWX	CSB324AWS	C324AEFY	13	13	

- (1) Pump model precedes rotor size. Example: CB324A-275
- (2) Figures 8 and 13 pumps can be equipped with a variety of mechanical seals as illustrated in Figures 9 through 12.
- (3) Mechanical seal, Figures 3 and 4, can be equipped with either seal seat as illustrated in Figures 9 or 10.
- (4) Special pump designs, denoted by X in model designators, have Bill of Material suffix (three or four digits) following rotor size designator.

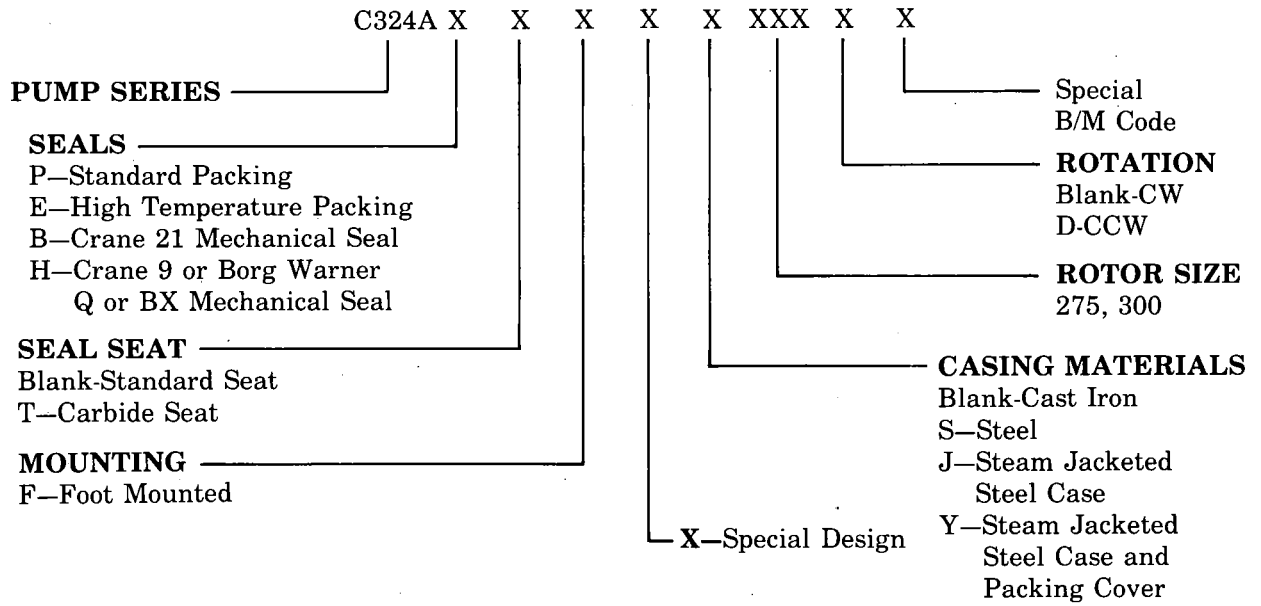

FIGURE 1. Definition of Model Designators for C324A Pumps

ORDERING INSTRUCTIONS

All correspondence pertaining to renewal parts for Series 324A pumps must refer to this instruction book number and should be addressed to the nearest IMO Pump Division Sales office or representative listed in CA-1 manual.

The following directions should be followed for renewal part orders:

- 1—Give the number of this instruction book.
- 2—Give the pump type and serial number of the pump from which part(s) is ordered.
- 3—Give the figure number(s) on which the pump type and sealing design part(s) are shown.

STRUCTURAL LIMITS

Operating conditions such as speed, fluid viscosity, inlet pressure, temperature, filtration, duty cycle, mounting, drive type, etc. are interrelated. Due to variable conditions, specific application limitations may vary from structural limitations. *This equipment must not be operated without verification that operating requirements are within published capabilities as shown in the appropriate pump data manuals* (available from local IMP Pump Division offices and representatives listed in manual CA-1).

Under no circumstances are the following structural limitations to be exceeded.

MAXIMUM SPEED: Contact the IMO Pump Division for rating Tables. For residual, crude oil and other fluids known to contain fine abrasives, pump speed should not exceed 1800 RPM.

VISCOSITY: 8.0 cst (50 SSU) Minimum. Consult factory for lighter viscosities.

Maximum for type B - 3000 SSU. For viscosities above 3000 SSU use packed pump or type H. Contact the IMO Pump Division for minimum allowable operating viscosity at specific speeds and pressures. Do not use packed pump for viscosity below 100 SSU.

TEMPERATURE:	Type P	0-250° F.
	Type E	0-500° F.
	Type B	0-160° F.
	Type H	0-250° F.

DRIVE: Direct only

FILTRATION: Light fluids—60 mesh
Heavy fluids— $\frac{1}{8}$ to $\frac{3}{16}$ -inch

PRESSURE: 500 PSIG

SUCTION: 25 PSIG Maximum

DISASSEMBLY AND ASSEMBLY PROCEDURES

UNIT REMOVAL

STEP 1. Deenergize electrical system and attach a "WARNING" Out-of-Service Tag. Disconnect steam or water piping and drain piping and pump.

STEP 2. Shut, lock and tag Out-of-Service the suction and discharge valves. Remove tubing (052) that must be replaced in its original installed position.

STEP 3. Disconnect coupling and remove pump from mounting.

STEP 4. Locate pump in a clean working area for disassembly.

DISASSEMBLY PROCEDURES

SPECIAL NOTE

Disassembly and assembly procedures are given for pump types and sealing designs by Figure Numbers only. Ensure that pump type is identified by proper Figure(s) for correct disassembly and assembly procedures. Refer to Table 1 for identification of pump types and applicable Figure Number(s).

STEP 1. *All Pumps:* Remove checknut (029), setscrew (030), key (055), and coupling hub from power rotor (013).

STEP 2. *Figures 8 and 13 only:* Remove nuts (005), bolts (006), and drip cup (019).

STEP 3. Remove packing or mechanical seal as follows:

Figures 8, 13 and 14: Remove nuts (023) and washers (024), turn gland bolts (022), remove capscrews (020) and slide gland sub-assembly (021) from power rotor (013). Using a "packing puller" or a sharp pointed brass or copper rod, remove the five installed packing rings (037).

Figures 8 and 13: Remove bolts (002) and packing box cover sub-assembly (017). Removal of packing box cover sub-assembly (017) includes removal of spring pins (028), plugs (009), plugs (051), check valve (052), washer (027), bushing (016), pins (035) and block (033). Slide washer (027) from cover (017). Remove block (033) and busing (016) from cover (017) if bushing is to be replaced. Unless check valve (052) must be replaced, no further disassembly of cover sub-assembly (017) is necessary.

Figure 14 only: Remove bolts (003) and packing box cover sub-assembly (017). Removal of packing box cover sub-assembly includes removal of spring pins (028), plugs (091), washer (027), busing (016), pins (035) and block (033). Slide washer (027) from cover (017). If bushing is to be replaced, remove block (033) and bushing (016) from cover (017).

Figures 9, 10, 11 and 12: Remove bolts (057) and seal cover sub-assembly (056). Removal of seal cover (056) includes removal of spring pin (085), seal seat and O-ring (Figures 9, 11 and 12) or seal seat and grommet (Figure 10), no-flare connector (049) and plugs (051). Remove seal seat with O-ring (1 and 2, Figure 3, 4, 5 or 6) or seal seat with grommet (1A and 2A, Figure 3 and 4) from seal cover (056). Slide mechanical seal (059), shim (062) and spacer (061) from power rotor (013). Remove gasket (058).
NOTE: If mechanical seal has setscrews, loosen setscrews to remove seal.

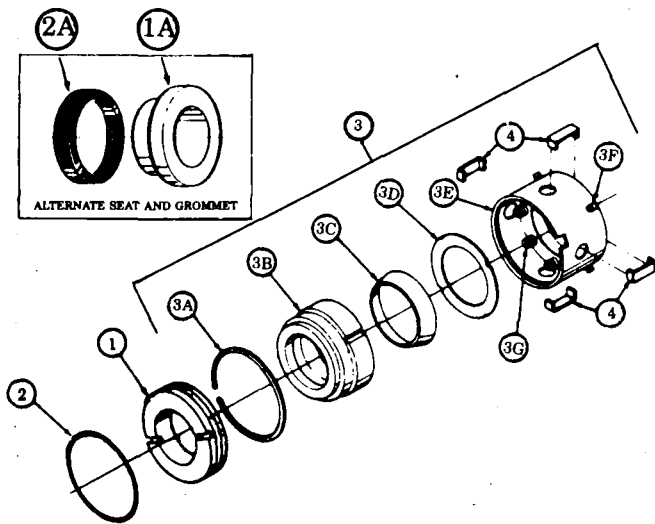

- 1. SEAT
- 1A. ALTERNATE SEAT
- 2. O-RING
- 2A. GROMMET
- 3. ROTATING ASSEMBLY
- 3A. SNAP RING
- 3B. WASHER
- 3C. CHEMLON RING
- 3D. DISC
- 3E. RETAINER
- 3F. SETSCREW
- 3G. SPRING
- 4. RETAINING CLIPS

FIGURE 3. Crane Type 9 Mechanical Seal.

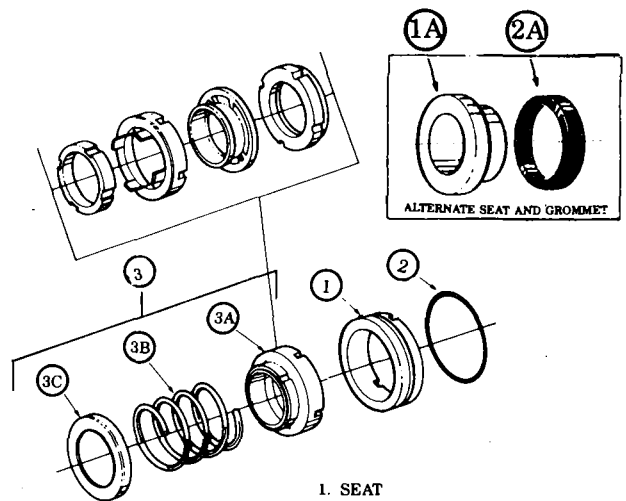

- 1. SEAT
- 1A. ALTERNATE SEAT
- 2. O-RING
- 2A. GROMMET
- 3. ROTATING ASSEMBLY
- 3A. WASHER BELLOWS ASSEMBLY
- 3B. SPRING
- 3C. SPRING HOLDER

FIGURE 4. Crane Type 21 Mechanical Seal.

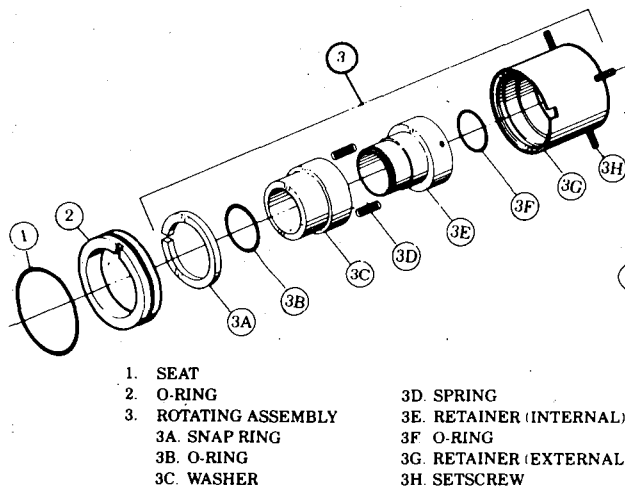

- 1. SEAT
- 2. O-RING
- 3. ROTATING ASSEMBLY
- 3A. SNAP RING
- 3B. O-RING
- 3C. WASHER
- 3D. SPRING
- 3E. RETAINER (INTERNAL)
- 3F. O-RING
- 3G. RETAINER (EXTERNAL)
- 3H. SETSCREW

FIGURE 5. Crane Type 8B3 Mechanical Seal.

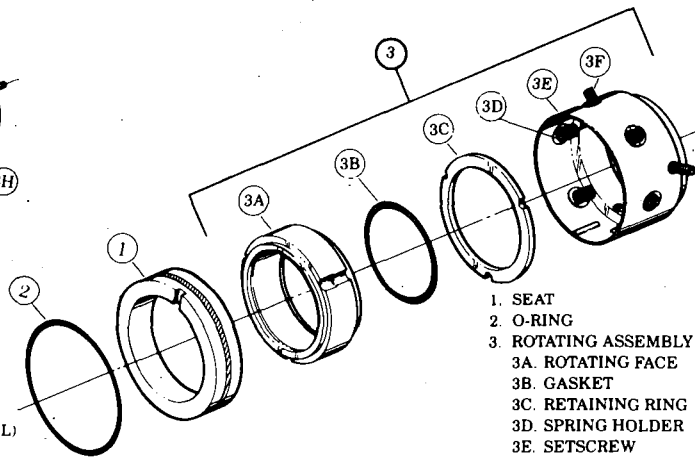

- 1. SEAT
- 2. O-RING
- 3. ROTATING ASSEMBLY
- 3A. ROTATING FACE
- 3B. GASKET
- 3C. RETAINING RING
- 3D. SPRING HOLDER
- 3E. SETSCREW
- 3F. SPRING

FIGURE 6. Borg Warner Type Q Mechanical Seal

Figure 12 only: Remove spacer (086) and gasket (058).

Figures 9, 10, 11 and 12: Remove bolts (003), inboard cover sub-assembly (065) and gasket (007). Removal of inboard cover (065) includes removal of spring pins (028), check valve (052), bushing (016), pins (035) and block (033). If bushing is to be replaced, remove block (033) and bushing (016) from cover (065). Unless check valve is to be replaced, no further disassembly of cover sub-assembly (065) is necessary.

NOTE: Disassembly procedures described in Steps 4 through 10 are identical for all pumps, Figures 8 through 14.

STEP 4. Remove inboard collar (043) with key (040).

STEP 5. Remove bolts (004), cover (031), gasket (008) and ring (044).

STEP 6. Remove bolts (003) and outboard cover (015). Removal of cover (015) will also remove bushing (025), pins (034 and 035) and block (032). If bushing is to be replaced, remove block (032) and bushing (025) from cover (015).

STEP 7. Remove outboard collar (042) with key (040) and shim (041) from power rotor (013).

STEP 8. Remove power rotor (013) and idlers (014) as an assembly from inboard end of pump. NOTE: As rotors slide from housings, wrap rotor assembly with a sling to prevent accidental dropping and to assist in holding rotors in mesh for easy removal.

STEP 9. Remove plugs (012) and stop pins (011) from case (001), ensuring that stop pins (011) are properly marked for position and alignment. If stop pins are to be replaced, or if match marks are not visible, make new markings before removal of pins. If new housings are required, new stop pins are also required. Tag each stop pin (011) to identify installed position.

STEP 10. Slide housings (010) from case (001). Removal of housings (010) will remove capscrews (038) and jam nuts (039). Unless new housings are required, capscrews (038) and jam nuts (039) should not be removed from housings. Slide spacer (026) from case (001).

ASSEMBLY PROCEDURES

SPECIAL NOTE

Prior to assembly of pump, all parts should be cleaned and inspected for burrs or nicks. Replace all worn or damaged parts. The IMO Pump Division recommends automatic replacement of gaskets, packing or mechanical seals when these parts are disturbed from their previously installed positions. Wipe all parts with light lubricating oil prior to assembly. Refer to Table 1 to identify correct Figure Numbers(2) for pump types. Assembly procedures are given for pump types and sealing designs by Figure Number(s) only.

STEP 1. *All Pumps:* Wipe spacer (026) with oil and slide spacer (026) into pump case (001). Align one open port of spacer (026) with outlet opening of pump case (001).

STEP 2. *All Pumps:* Wipe inboard housing (010) with oil; align stop pin slot and slide housing (010) into case inboard end until housing (010) contacts spacer (026). With housing (010) stop pin slot aligned with case (001) stop pin slot, install stop pin (011) and plug (012) in inboard end. Wipe outboard housing (010) with oil and install in outboard end of pump case as described above. Install stop pin (011) and plug (012) in outboard end. NOTE: If new housings are installed, new stop pins must be fitted and installed to ensure proper housing alignment. To fit new stop pins, file or grind one or both flat surfaces of stop pin until pin fits snugly into housing slot. DO NOT over grind flat surfaces. If stop pins do not fit snugly to housing, housings may rotate out of position during operation, causing damage to rotor assembly.

NOTE: To ensure proper housing alignment, slide idlers (014) into idler bores of housing (010) and slide idlers back and forth to check for binding, indicating misalignment of housings. Remove idlers when housing alignment is verified.

STEP 3. Assemble inboard cover as follows:

Figures 8, 13 and 14: Coat bushing (016) with oil and place bushing (016) in inboard cover sub-assembly (017). Align block (033) with spring pin (035) in bushing (016) and spring pin in cover sub-assembly (017) and install block (033) on inboard cover sub-assembly (017).

Figures 9, 10, 11 and 12: Coat bushing (016) with oil and place bushing (016) in inboard cover sub-assembly (065). Align block (033) with spring pin (035) in bushing (016) and spring pin in cover sub-assembly (065) and install block (033) on inboard cover sub-assembly (065).

NOTE: (All Pumps) If check valve (052) was removed during disassembly, install check valve (052) in inboard cover.

STEP 4. All Pumps: Coat bushing (025) and spacer (044) with oil and slide bushing (025) and spacer (044) in outboard cover (015). Align block (032) with spring pins (034 and 035) in bushing (025) and outboard cover (015) and install block (033) on cover (015). Install gasket (008) and cover (031) on outboard cover (015) using bolts (004). Torque bolts (004) to 28 lbs ft. (± 2 lbs. ft.).

STEP 5. All Pumps: Adjust screws (038) on inboard and outboard ends of housings as outlined in Figure 7. Correct adjustment should be verified for inboard end before adjusting screws on outboard end. Place bluing or fuse wire on heads of capscrews (038). Install inboard cover (assembled in Step 3) as follows:

Figures 8, 13 and 14: Attach inboard cover sub-assembly (017) and gasket (007) on case (001) using bolts (002, Figures 8 and 13) or (003, Figure 14). Torque bolts (002 or 003) to 85 lbs ft. (± 5 lbs. ft.).

Figures 9, 10, 11 and 12: Attach inboard cover sub-assembly (065) and gasket (007) on case (001) using bolts (003). Torque bolts (003) to 85 lbs ft. (± 5 lbs. ft.).

All Pumps: Install assembled outboard cover (015) (assembled in step 4) and gasket (007) to case (001) using bolts (003). Torque bolts (003) to 85 lbs ft. (± 5 lbs. ft.). Remove inboard cover and verify capscrew (038) contact on block (033). Adjust capscrews (038) as necessary. Ensure jam nuts (039) are locked tight. Install inboard cover as outlined above per Figure Numbers. Torque bolts (002) to 85 lbs ft. (± 5 lbs. ft.) on Figures 8, 13 and 14. Torque bolts (003) to 85 lbs ft. (± 5 lbs. ft.) on Figures 9, 10, 11 and 12. With proper adjustment verified for inboard end capscrews (038), perform procedure outlined for adjusting screws on outboard end, Figure 7. Remove outboard cover (015) and check for contact between block (032) and screws (038). Adjust capscrews (038) as necessary. Ensure jam nuts (039) are locked tight. Outboard cover (015) will be re-installed in Step 8. **CAUTION:** Do not exceed 0.003" pressure on capscrews (038) to avoid distortion of rotor housing bores.

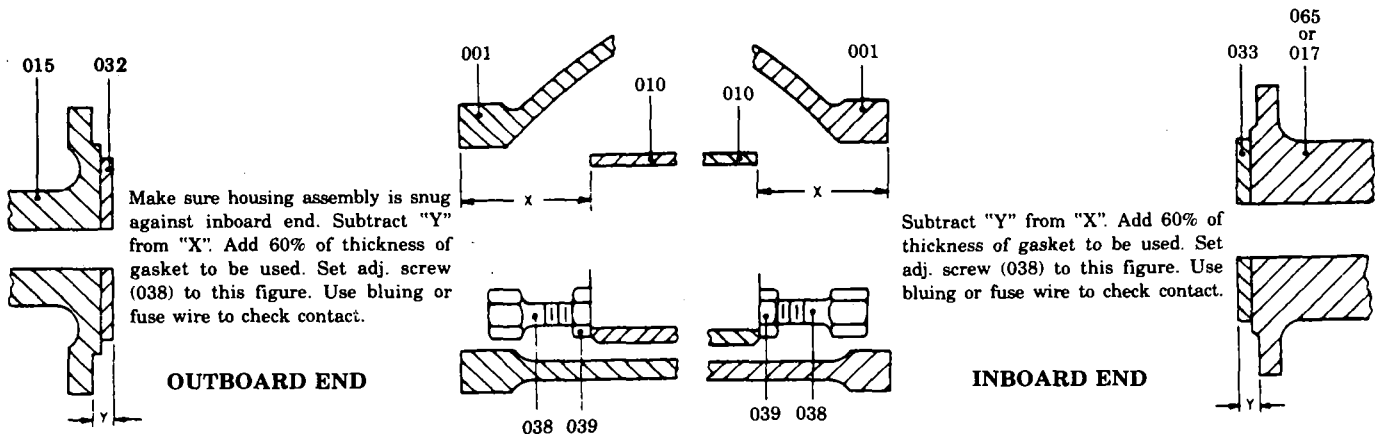

FIGURE 7. Setting of Housing Adjusting Screws

STEP 6. All Pumps: Place key (040) in inboard key slot of power rotor (013). Align inboard collar (043) with key (040) and slide collar (043) on power rotor (013). Slide shim (041) on outboard end of power rotor (013). Place key (040) in power rotor outboard end key slot. Align outboard collar (042) with key (040) and slide collar (042) on power rotor (013).

STEP 7. All Pumps: Coat assembled power rotor (013) and idlers (014) with oil. Slide rotor assembly, power rotor (013) and idlers (014), in pump from outboard end. Power rotor and idlers should be in mesh for ease of insertion into rotor bores.

STEP 8. All Pumps: Install assembled outboard cover (015) and gasket (007) to case (001) using bolts (003). Torque bolts (003) to 85 lbs ft. (± 5 lbs. ft.).

STEP 9. All Pumps: Mount a dial indicator on inboard cover to measure power rotor (013) end clearance (axial movement). Axial movement should be $\frac{1}{16}$ -inch ($+\frac{1}{64}$ -inch, -0) for packing pumps (Figures 8, 13 and 14) or 0.030-inch ($+0.005$ -inch, -0) on pumps equipped with a mechanical seal (Figures 9, 10, 11 and 12). If end clearance must be adjusted, remove outboard cover (015) collar (042) and key (040). Add or remove layers of shim (041) to obtain desired clearance. Replace key (040) and outboard collar (042). Replace outboard cover (015) and torque bolts (003) to 85 lbs ft. (± 5 lbs. ft.).

STEP 10. Install Packing or Mechanical Seal and cover. NOTE: Figures 8, 13 and 14 are packing pumps. Figures 9, 10, 11 and 12 are pumps with mechanical seals.

Figures 8, 13 and 14: Slide washer (027) in inboard cover (017). Install five new packing rings (037) in gland sub-assembly (021). Set each packing ring individually and firmly in place, starting with one ring of hard packing, followed with one ring of soft packing, etc. to end with another ring of hard packing. Slide packing gland sub-assembly (021) on power rotor (013). Install capscrews (020) in glands (086 and 087). Turn gland bolts (022) parallel with power rotor (013) and slide packing gland sub-assembly (021) to packing bore of power rotor (013). Slide washers (024) on gland bolts (022) and install nuts (023). Tighten gland nuts (023) evenly and hand tight. NOTE: If plugs (009) and 051, Figures 8 and 13) or (091, Figure 14) were removed during disassembly, install plugs in case (001).

NOTE: When pump is operating, adjust gland nuts (023) to allow packing gland seepage of approximately 8 drops per minute for rotor lubrication. DO NOT overtighten packing, or damage will occur to power rotor.

Figure 12: Install gasket (058) and spacer (086) on inboard cover (065).

Figures 9, 10, 11 and 12: Install gasket (058) and seal cover (056) on inboard cover (065) using bolts (057). Torque bolts (057) to 55 lbs ft. (± 5 lbs. ft.). Pull power rotor in axial direction until inboard collar (043) is in contact with block (033). Mark power rotor shaft where it starts to extend through seal cover (056) to use as a reference point for setting operating length of mechanical seal. Remove bolts (057), seal cover (056) and gasket (058). Slide spacer (061) and shim (062) on power rotor (013) until spacer is in contact with step-cut shoulder of power rotor. Measure distance from power rotor scribe mark back to nearest surface of spacer (061). Identify measured distance as "X" to be used in determining seal working length. Determine required working length of mechanical seal from Table 2 and identify length as distance "S." Continue assembly per applicable Figure Number.

**TABLE 2
MECHANICAL SEAL WORKING LENGTH**

SEAL FIG. NO.	SEAL SEAT FIG. NO.	SEAL WORKING LENGTH
3 or 4	9 or 10	$1\frac{3}{8}$ -inch ($\pm \frac{1}{64}$ -inch)
5	12	$2\frac{1}{8}$ -inch ($\pm \frac{1}{64}$ -inch)
6	10	$1\frac{11}{16}$ -inch ($\pm \frac{1}{64}$ -inch)
11	11	$1\frac{7}{16}$ -inch ($\pm \frac{1}{64}$ -inch)

Figures 9, 10, 11 and 12: Install O-ring (2, Figures 3, 4, 5 or 6) on seal seat (1, Figures 3, 4, 5, or 6) or grommet (2A, Figures 3 or 4) on seal seat (1A, Figures 3 or 4). Slide assembled seal seat in seal cover sub-assembly (065).

NOTE: O-ring (Figure 11) may be located on seal seat or in seal cover (056, Figure 12).

Measure thickness of power rotor bore of seal cover (056) including mechanical seal thickness and identify measured thickness as distance "Y." Determine required thickness of shim (062) by adding seal working length "S" to thickness of seal cover bore "Y" and subtracting the total from power rotor length "X."

$$\text{SHIM THICKNESS (062)} = X - (Y + S)$$

Add or subtract layers of shim (062) until required thickness is obtained for proper seal working length. Slide shim (062) on power rotor (013). Install mechanical seal rotating parts as follows:

Crane 9 (Figure 3), Crane 8B3 (Figure 5) and Borg Warner Q (Figure 6) Mechanical Seals: Slide mechanical seal rotating assembly (3) on power rotor (013) with rotating assembly in contact with shim (062). Tighten setscrews. Remove and discard retaining clips (004) if provided prior to final tightening of set screws.

Crane 21 Mechanical Seal (Figure 4): Slide mechanical seal rotating assembly (3) on power rotor (013) with spring holder (3C) next to shim (062).

Sealol Seal (Figure 11): Slide mechanical seal (059) rotating assembly on power rotor (013) with drive collar fitted next to shim (062) and tighten set screws.

STEP 11. *Figures 9, 10, 11 and 12:* Install gasket (058) and seal cover sub-assembly (056) using bolts (057). Torque bolts (057) to 55 lbs ft. (\pm 5 lbs. ft.).

STEP 12. *Figures 8 and 13 only:* Install drip cup (019) with bolt (006) and nut (005).

STEP 13. *All Pumps:* Install key (055) in key slot of power rotor and slide coupling hub on power rotor (013). Install setscrew (030) and checknut (029).

UNIT ASSEMBLY

STEP 1. Mount pump on base plate and follow mounting instructions in the CA-1 manual.

STEP 2. Install tubing (050). Connect pump piping and install all drain plugs.

STEP 3. Open suction and discharge valves. Remove "Out-of-Service" Tags and locks. Rotate pump shaft by hand to fill pump with fluid and expel all air.

STEP 4. Energize electrical system.

STEP 5. Adjust flow control needle valve (048) as required to ensure proper cooling in packing/seal chamber.

TABLE 3
LIST OF MATERIAL FOR FIGURES 8 THROUGH 14

ITEM	PART DESCRIPTION	ITEM	PART DESCRIPTION	ITEM	PART DESCRIPTION
001	Case	027	Washer	055	Key
002	Bolt (8)	028	Spring Pin (2) (Part of	056	Seal Cover Sub-Assy.
003 (3)	Bolt (8)		Item 017 or 065)		(Includes Items 084
004	Bolt (4)	029	Check Nut		and 085)
005	Bolt	030	Setscrew	057	Bolt (4)
006	Nut	031	Cover	058 (1)	Gasket
007 (1)	Gasket (2)	032 (2)	Block	(059) (1)	Seal
008 (1)	Gasket	033 (2)	Block	061 (2)	Spacer
009	Plug (4)	034 (2)	Pin (4)	062 (1)	Shim
010 (2)	Housing (2)	035 (2)	Pin (2)	065	Inboard Cover Sub-
011 (2)	Stop Pin (2)	036	Nipple		Assy. (Includes Items
012	Plug (2)	037 (1)	Packing		028 and 066)
013 (2)	Power Rotor	038 (2)	Capscrew (4)	066	Inboard Cover (Part of
014 (2)	Idler (2)	039 (2)	Jam Nut (4)		Item 065)
015	Outboard Cover	040 (2)	Woodruff Key (2)	068	Drive Screw (3)
016 (2)	Bushing	041 (2)	Shim (3)	070	Cap (4)
017	Packing Box Cover	042 (2)	Outboard Collar	080	Valve (Part of Item
	Sub-Assy. (Includes	043 (2)	Inboard Collar		048)
	Items 028	044	Ring	081	Elastic Nut (Part of
	and 054)	045	Name Plate		Item 048)
018	Spring Pin (2)	046	Name Plate	082	Pin (part of Item 048)
019	Drip Cup	047	Name Plate	083	Body (Part of Item
020	Capscrew (2)	048	Needle Valve Sub-Assy.		048)
	(Part of Item 021)		(Includes Items 080,	084	Seal Cover (Part of
021	Gland Sub-Assy.		081,082, and 083)		Item 056)
	(Includes Items 020,	049	No Flare Connector (2)	085	Spring Pin (Part of
	086, and 087)	050	Tubing		Item 056)
022	Gland Bolt (2)	051	Plug (2)	086 (4)	Gland (Part of Item
023	Nut (2)	052 (2)	Check Valve		021)
024	Washer (2)	053	Drive Screw (4)	087	Gland (Part of Item
025 (2)	Bushing	054	Packing Box Cover		021)
026	Spacer		(Part of Item 017)	091	Plug (3)

(1) Minor Repair Kit Items.

(2) Major Repair Kit Items. Items marked (1) are also included in Major Repair Kit.

(3) Quantity of item 003 is 16 for pumps with mechanical seals.

(4) Figure 12 part description — Spacer.

Quantities are one (1) except when noted in parentheses after part description.

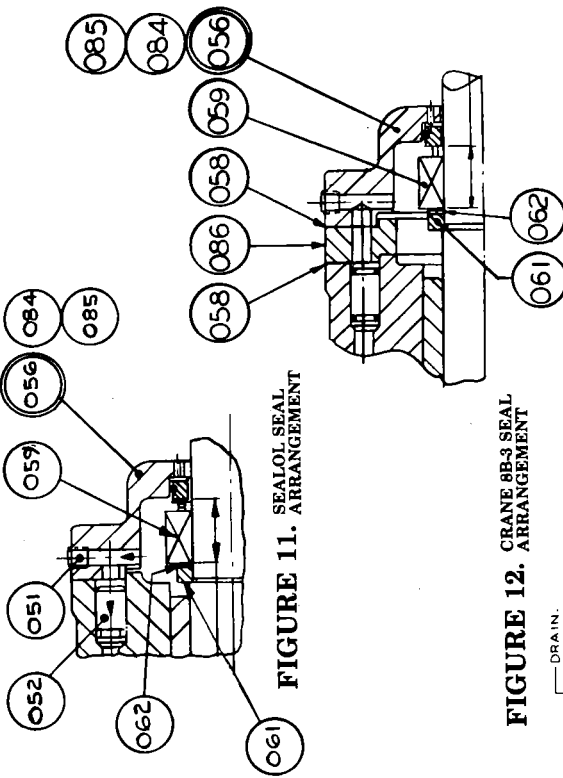

FIGURE 12. CRANE 8B-3 SEAL ARRANGEMENT

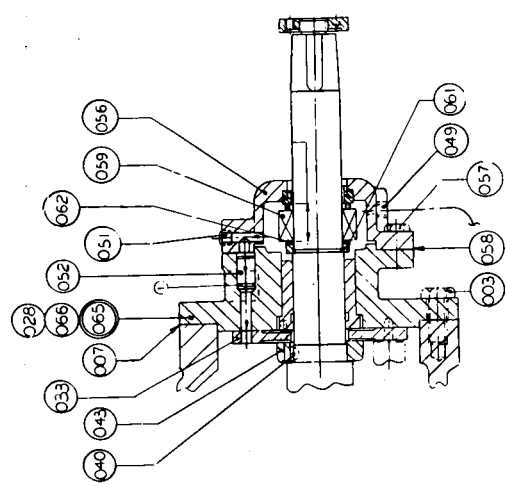
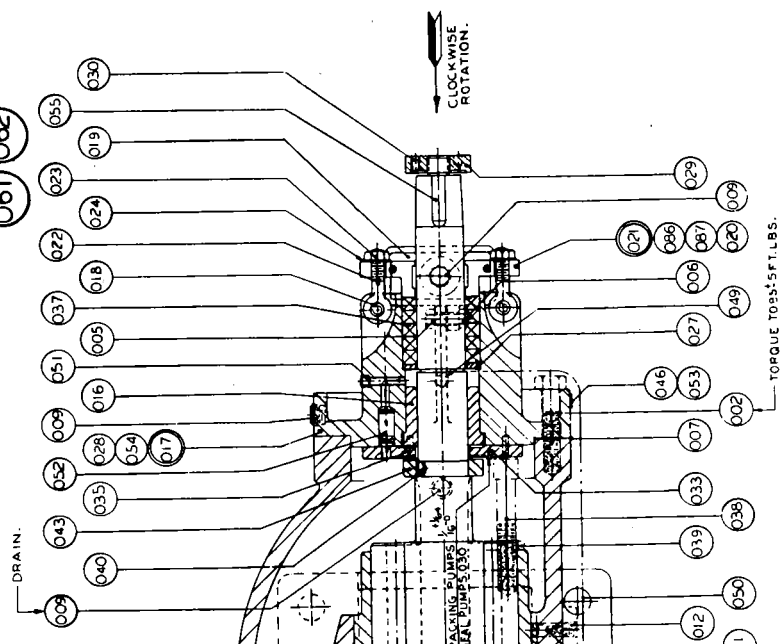

FIGURE 10. VIEW OF INBOARD END COVER SEAL WITH SQUARE RING SEAT

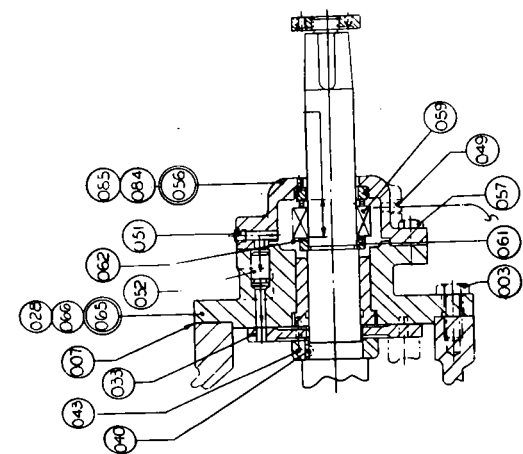
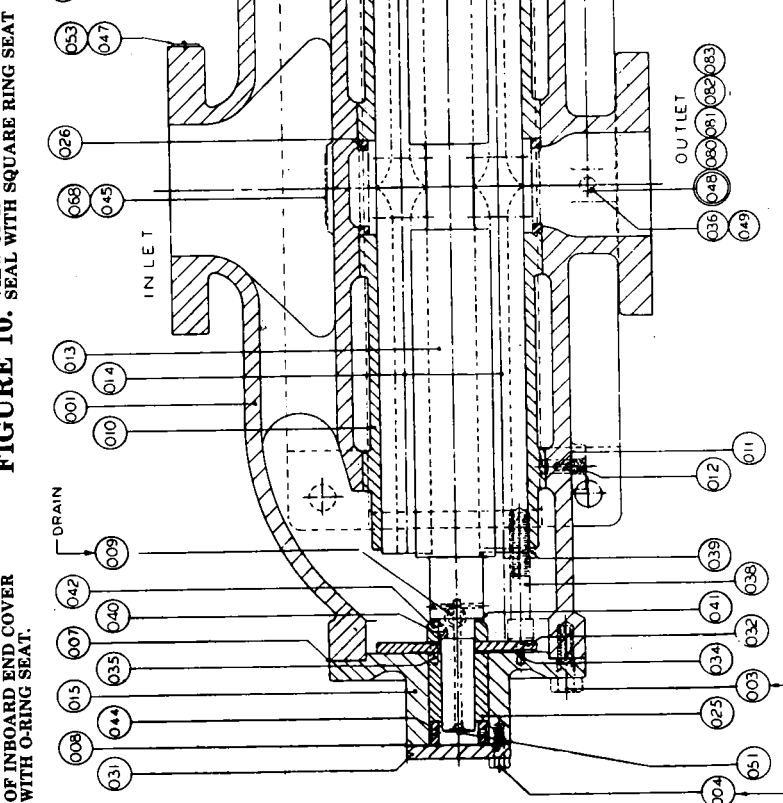

FIGURE 8.

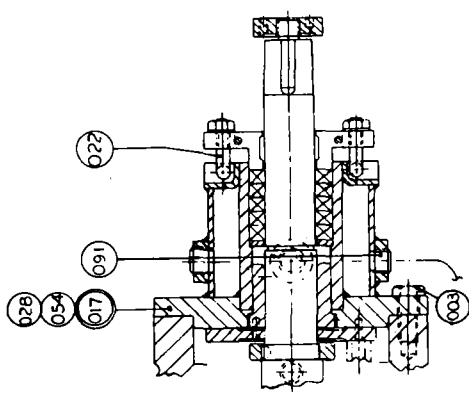

FIGURE 14. VIEW OF INBOARD END WITH WELDED PACKING BOX COVER

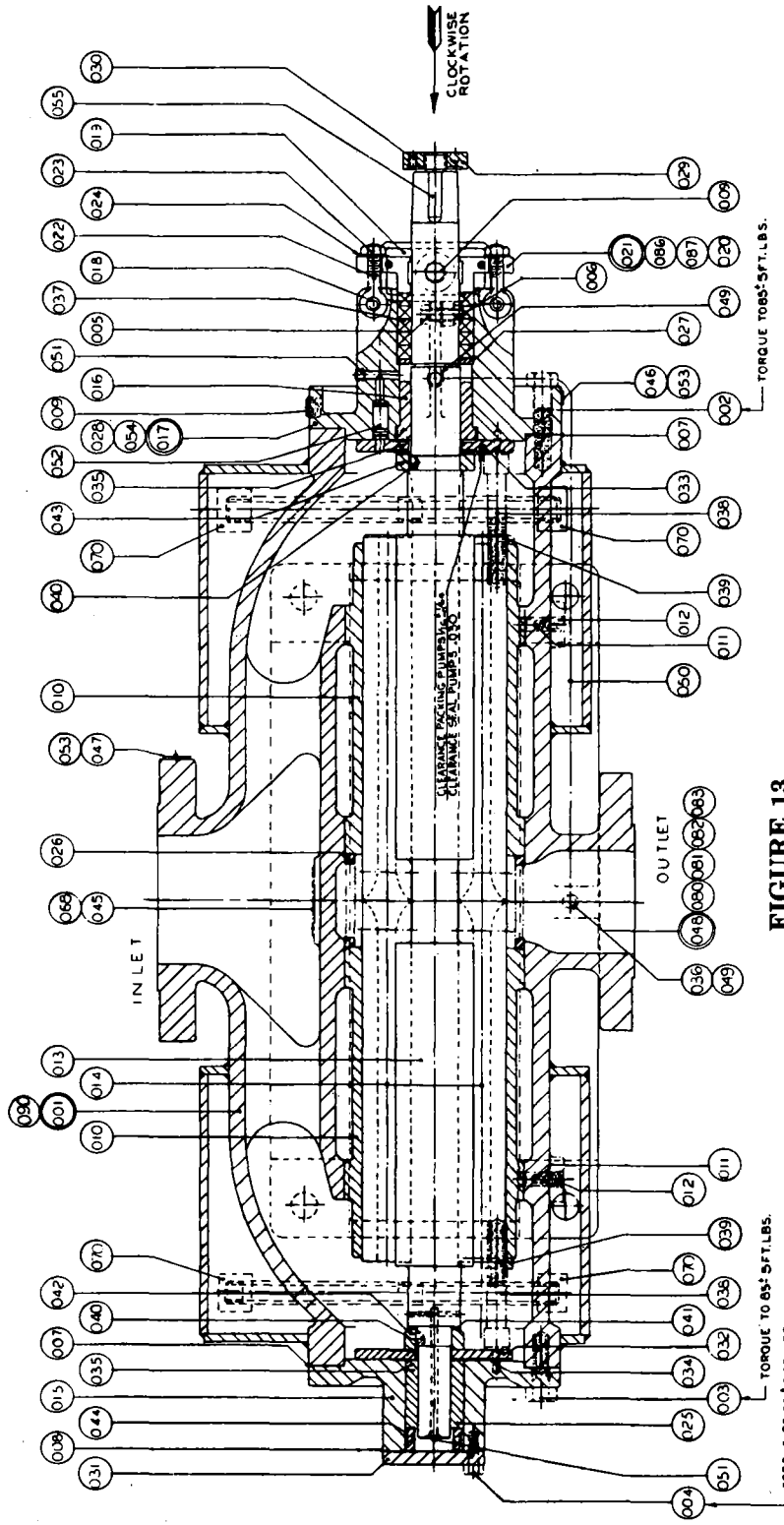

FIGURE 13.