



## INSTRUCTIONS AND PARTS LIST

# SERIES TA324N-400 & 400P

### WARNING

**READ CA-1 AND THIS INSTRUCTION MANUAL PRIOR TO  
INSTALLATION, OPERATION OR MAINTENANCE**

**Instructions TA324N Rev. 0**

This manual now is  
identified as part no.  
SRM00068

**Imo Pump**  
1710 Airport Road  
PO Box 5020  
Monroe, NC  
28111.5020

tel 704.289.6511  
fax 704.289.9273

**April, 1997**

The instructions given herein cover generally the operation and maintenance of subject equipment. Should any questions arise which may not be answered specifically by these instructions, they should be referred to the Imo Pump for further detailed information and technical assistance.

This manual cannot possibly cover every situation connected with the operation, adjustment, inspection, test, overhaul and maintenance of the equipment furnished. Every effort is made to prepare the text of the manual so that engineering and design data is transformed into the most easily understood wording. Imo Pump, in furnishing this equipment and this manual, must presume that the operating and maintenance personnel assigned thereto have sufficient technical knowledge and experience to apply sound safety and operational practices which may not be otherwise covered herein.

In applications where Imo Pump furnished equipment is to be integrated with a process or other machinery, these instructions should be thoroughly reviewed to determine the proper integration of the equipment into the overall plant operational procedures. On critical or dangerous equipment, provide suitable safety and emergency systems to protect personnel and property from injury due to pump malfunction. If pump handles flammable, toxic, corrosive, or explosive fluids, provide for safety in the event of pump leakage or malfunction.

If the installation, operation, and maintenance instructions are not correctly and strictly followed and observed, serious damage to the pump could result. Imo Pump cannot accept responsibility for unsatisfactory performance or damage resulting from failure to comply with instructions

## FOREWORD

This instruction manual covers Series TA324N, rotor sizes 400 and 400P, IMO pumps. Because of the large number of operating conditions, it is necessary to have different construction and material combinations in order to provide the proper pump for specific job specifications. Standard TA324N pumps are provided with bronze housings (figure 4). For special applications, bimetal housings are provided (figure 7). Figures 5 and 6 are the same pump construction as figure 4 except for the use of different mechanical seals. TA324N pumps can be supplied with a John Crane Type 21 mechanical seal (figure 1, illustrated on figure 4), Borg Warner Type Q (figure 2, illustrated on figures 6 and 7) or Borg Warner Type BXQ (figure 3, illustrated on figure 5). The model of each pump is identified on the pump nameplate.

This instruction manual identifies pump types and sealing designs by figure numbers only. For maintenance, disassembly and assembly procedures, ensure that specific pump type and mechanical seal type are identified with correct figure number. Disassembly and assembly procedures pertain to all pump types unless specifically noted for a particular figure number.

## ORDERING INSTRUCTIONS

All correspondence pertaining to renewal parts for Series TA324N pumps must refer to this instruction manual number and should be addressed to the nearest Imo Pump representative listed in Manual CA-1.

The following directions should be followed for renewal part orders:

1. Give the number of this instruction manual.
2. Give the pump type and serial number of the pump for which part(s) is ordered.
3. Give the figure number(s) on which the pump type and sealing design part(s) are shown.

## STRUCTURAL LIMITS

Operating conditions such as speed, fluid, viscosity, inlet pressure, temperature, filtration, duty cycle, mounting, driving type, etc. are interrelated. Due to variable conditions, specific application limitations may vary from structural limitations. **This equipment must not be operated without certification that operating requirements are within published capabilities as shown in the appropriate pump brochure** (available from local Imo Pump offices and representatives listed in Manual CA-1).

## DISASSEMBLY OF PUMP

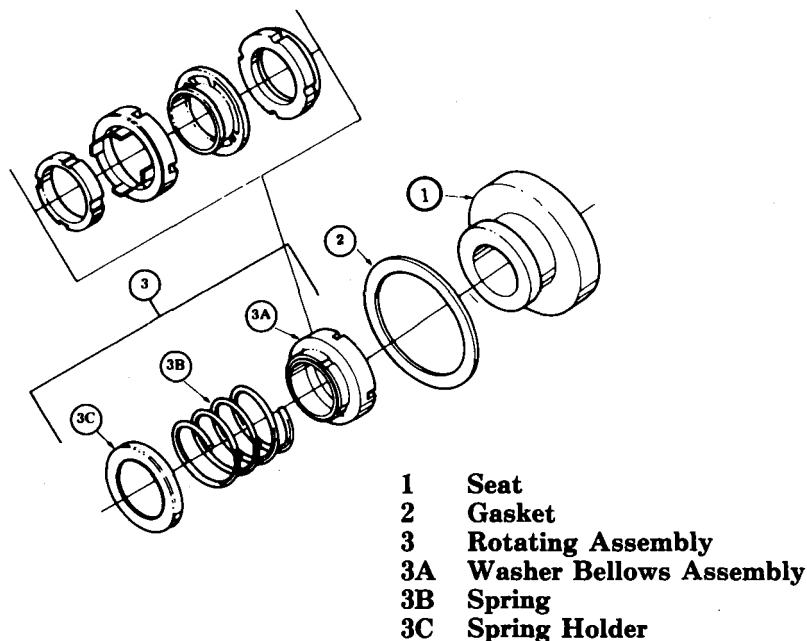
1. Deenergize electrical system and attach a WARNING, "Out-of-Service" tag. Close, lock and tag "Out-of-Service" the inlet and outlet valves. Vent pressure from pump. Remove plugs (060 and 010) and plug (030) with O-ring (031) and drain pump. Disconnect inlet and outlet flanges.
2. Loosen setscrew (044) and remove check nut (043). Remove coupling hub and key (045) from power rotor (025) shaft.
3. Remove pump mounting bolts, and remove pump from mounting or rotate pump on mounting so that sufficient space is available for removing pump parts.
4. Remove nuts (006), lockwashers (009) and bolts (005). Using slings to support weight and to keep rotors in mesh, pull assembled cover (002) and rotor assembly [power rotor (025) and idler rotors (026 and 027)] from pump. Use extreme caution to ensure that slings are attached as rotor assembly emerges from housing bores to support weight and to avoid dropping of any parts.

5. Remove idler rotors (026 and 027) from power rotor (025).

**NOTE**

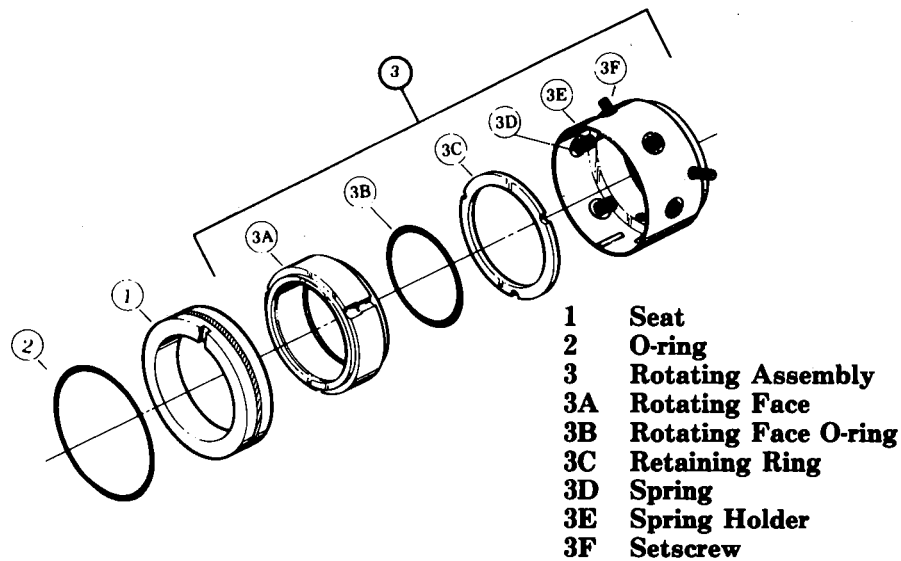
Idler rotors (026 and 027) are furnished as an assembly with flexible joints (figure 8) and should not be disassembled.

6. Remove gasket (011) from either flange of cover (002) or flange of case (001).
7. Remove bearing locknut (028) and bearing lockwasher (029) from power rotor (025) shaft.
8. Support cover (002) and press power rotor (025) from cover, using extreme caution to avoid damage to power rotor. Removal of power rotor (025) will also remove O-ring (036) and spacer (069). Remove O-ring (036) from groove of power rotor (025) shaft. If necessary for replacement, remove spacer (069) from power rotor (025) shaft.
9. Remove bolts (007) with lockwashers (008) and bearing retainer (004) from cover (002).
10. Remove ball bearing (034) from cover (002).
11. (Figure 4) Remove spacer (013), slinger (040) and spacer (035) from cover (002). Remove sleeve (032) from cover (002). Removal of sleeve (032) also removes spiral ring (039), and mechanical seal (038). Remove spiral ring (039) from groove of sleeve (032). Remove stationary seat (1, figure 1) and rotating assembly (3, figure 1) of mechanical seal (038) from sleeve (032). Remove gasket furnished with mechanical seal (038) from counterbore of cover (002).

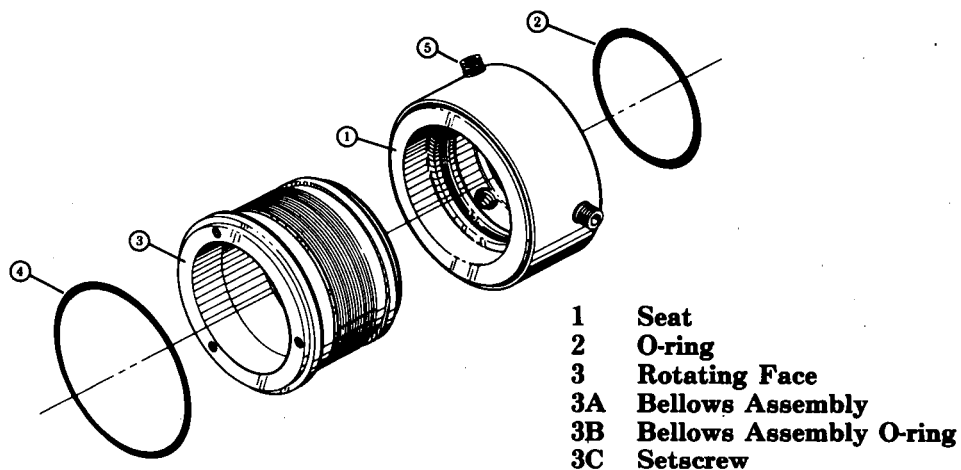


**FIGURE 1. John Crane Type 21 Mechanical Seal**

12. (Figures 5, 6 and 7) Remove spacer (013) and slinger (040) from cover (002). Remove sleeve (032) from cover (002). Removal of sleeve (032) will also remove spiral ring (039), seat subassembly (082, figures 5 and 6) or (015, figure 7), mechanical seal (038) and spacer (081, figure 5). Remove spiral ring (039) from groove of sleeve (032). Remove seat subassembly (082, figures 5 and 6) or (015, figure 7) from sleeve (032). Removal of seat subassembly (082 or 015) will also remove mechanical seal stationary seat and O-ring (1 and 2, figures 2 and 3). Remove stationary seat and O-ring (1 and 2, figures 2 and 3) from seat subassembly (082 or 015). Remove O-ring (2, figures 2 and 3) from stationary seat (1, figures 2 and 3). Loosen setscrews (3F, figure 2 and 3C, figure 3), and remove mechanical seal rotating assembly (3, figures 2 and 3) from sleeve (032). If necessary for replacement, remove spacer (081, figure 5) from sleeve (032). Remove gasket (014) from counterbore of cover (002).



**FIGURE 2. Borg-Warner Type Q Mechanical Seal**



**FIGURE 3. Borg-Warner Type BXQ Mechanical Seal**

13. Remove capscrews (066) and stops (071) from cover (002).
14. Remove nuts (006), lockwashers (009) and bolts (005). Remove cover (003) with stop (065). Remove capscrews (066) and stop (065) from cover (003). Remove gasket (011) from either flange of cover (003) or flange of case (001).
15. Remove plugs (024), O-rings (023) and housing stop pins (022).
16. Remove outer spiral rings (016) from grooves of inboard and outboard ends of case (001).
17. (Figure 7) Remove spacers (080) from inboard and outboard ends of case (001).
18. Install eyebolts into bores of housings (017) to aid in removal of housings. Remove outboard housing (017) from outboard end of pump case (001). Remove inboard housing (017) from inboard end of pump case (001).
19. (Figure 4) Removal of housings (017) will also remove O-rings (076) and spacers (073) with O-rings (074) and spiral rings (075). Remove spiral rings (075) from grooves of inboard and outboard housings (017). Remove spacers (073) from inboard and outboard housings (017). Remove O-rings (074) from grooves of spacers (073). Remove O-rings (076) from grooves of inboard and outboard housings (017).
20. (Figure 7) Removal of housings (017) will also remove O-rings (074). Remove O-rings (074) from grooves of inboard and outboard housings (017).

NOTE: Inner spiral rings (016) are installed for positioning of housings only and should not be removed.

### ASSEMBLY OF PUMP

Prior to assembly of pump, all parts should be cleaned and inspected for nicks and burrs. All worn or damaged parts should be replaced. IMO Pump Division recommends automatic replacement of ball bearing (034), mechanical seal (038), gaskets (011 and 014), O-rings (023, 031, 036, 074 and 076) and spiral rings (016, 039 and 075) when these parts are disturbed from their previous installed position. Wipe all parts with light lubricating oil prior to assembly. Do not permit removed parts to stand with machined surfaces exposed for extended periods of time. Check all oil passages to ensure that they are clean and free of debris.

1. (Figure 4) Install O-rings (076) in grooves of inboard and outboard housings (017). Install O-rings (074) in grooves of spacers (073). Install spacers (073) on inboard and outboard housings (017). Install spiral rings (075) in grooves of inboard and outboard housings (017).
2. (Figure 7) Install O-rings (074) in grooves of inboard and outboard housings (017).
3. Using eyebolts installed in housings in step 18 of Pump Disassembly, install outboard housing (017) from outboard end of pump case and inboard housing (017) from inboard end of case (001), aligning slots of housings with bores of case for stop pins (022). Use caution to avoid damage to installed O-rings. Remove eyebolts.
4. (Figure 7) Install spacers (080) in inboard and outboard ends of case (001).
5. Install outer spiral rings (016) in grooves of inboard and outboard ends of case (001).
6. Install housing stop pins (022). Install O-rings (023) and plugs (024).

7. If removed during pump disassembly for replacement, install spacer (069) on power rotor (025) shaft next to step-cut shoulder of shaft.
8. (Figure 4) Install rotating assembly (3, figure 1) of mechanical seal (038) on sleeve (032) next to step-cut shoulder of sleeve. Install stationary seat (1, figure 1) of mechanical seal (038) on sleeve (032) next to rotating assembly. Install spiral ring (039) in groove of sleeve (032) to retain mechanical seal. Install O-ring (036) in groove of power rotor (025) shaft. Install assembled sleeve (032) on power rotor (025) shaft, using caution to avoid damage to O-ring (036). Install spacer (035), slinger (040), and spacer (013) on power rotor (025) shaft.
9. (Figure 5) If removed for replacement, install spacer (081) on sleeve (032) next to step-cut shoulder of sleeve.
10. (Figures 5,6 and 7) Install rotating assembly (3, figures 2 and 3) on sleeve (032) next to step-cut shoulder of sleeve (figures 6 and 7) or installed spacer (081, figure 5). Tighten setscrews (3F, figure 2 and 3C, figure 3). Install O-ring (2, figures 2 and 3) on stationary seat (1, figures 2 and 3). Install assembled seat (1 and 2, figures 2 and 3) of mechanical seal (038) on seat subassembly (082, figures 5 and 6) or (015, figure 7), ensuring that spring pin (084, figures 5 and 6) or (018, figure 7) engages slot of seat (1, figures 2 and 3). Install assembled seat subassembly (082, figures 5 and 6) or (015, figure 7) on sleeve (032) next to mechanical seal rotating assembly. Install spiral ring (039) in groove of sleeve (032) to retain mechanical seal. Install O-ring (036) in groove of power rotor (025) shaft. Install assembled sleeve (032) on power rotor (025) shaft, using caution to avoid damage to O-ring (036). Install slinger (040) and spacer (013) on power rotor (025) shaft.
11. Slide ball bearing (034) on power rotor (025) shaft. Install bearing lockwasher (029) and bearing locknut (028) on power rotor (025) shaft. Tighten bearing locknut (028) to push ball bearing (034) onto power rotor shaft until bearing is properly seated.
12. Install gasket furnished with mechanical seal (figure 4) or gasket (014, figures 5, 6 and 7) in counterbore of cover (002).
13. Install cover (002) on assembled power rotor (025), using extreme caution to avoid damage to power rotor and installed mechanical seal and gasket installed in cover (002).

NOTE: If an oven is available, ball bearing can be heated to approximately 200 degrees F to assist in installation of ball bearing on power rotor shaft.

14. Install bearing retainer (004) on cover (002) using lockwashers (008) and bolts (007).
15. Install stops (071) on cover (002) using capscrews (066).
16. Install gasket (011) on flange of case (001).

#### NOTE

Idler rotors (026 and 027) are furnished as an assembly with flexible joints (figure 8) and must be installed as an assembly.

17. Install grease fitting into pipe plug bore (057, figure 8) (1/8-27 NPT thread) and fill flexible joint of idler rotors (026 and 027) with standard ball or roller bearing lubricant until grease begins to fill void in washer (058, figure 8) area.

18. Mesh threads of idler rotor (026 and 027) assemblies with threads of power rotor (025). Using slings to support weight and to keep threads of rotors in mesh, install rotor assembly [power rotor (025) and idler rotors (026 and 027)] and cover (002) from inboard end of pump case. Use caution to avoid damage to gasket (011) and parts installed on power rotor (025).
19. Install bolts (005) with lockwashers (009) and nuts (006) to fasten cover (002) to case (001).
20. Install stop (065) on cover (003) using capscrews (066). Install gasket (011) flat on outboard flange of case (001). Install cover (003) on case (001) using bolts (005) with lockwashers (009) and nuts (006). Use caution to avoid damage to gasket (011).

NOTE: Rotate power rotor (025) by hand to ensure freedom of rotation.

21. Install plug (030) with O-ring (031). Install plugs (060 and 010).
22. Install assembled pump on mounting. Install key (045) in key groove of power rotor (025) shaft. Install coupling hub. Install check nut (043) and setscrew (044) to lock coupling hub on power rotor (025) shaft.
23. Verify pump and driver alignment as outlined in Manual CA-1. Remove WARNING, "Out-of-Service" tags. Connect inlet and outlet flanges. Start pump as outlined in Manual CA-1.



## LIST OF MATERIAL

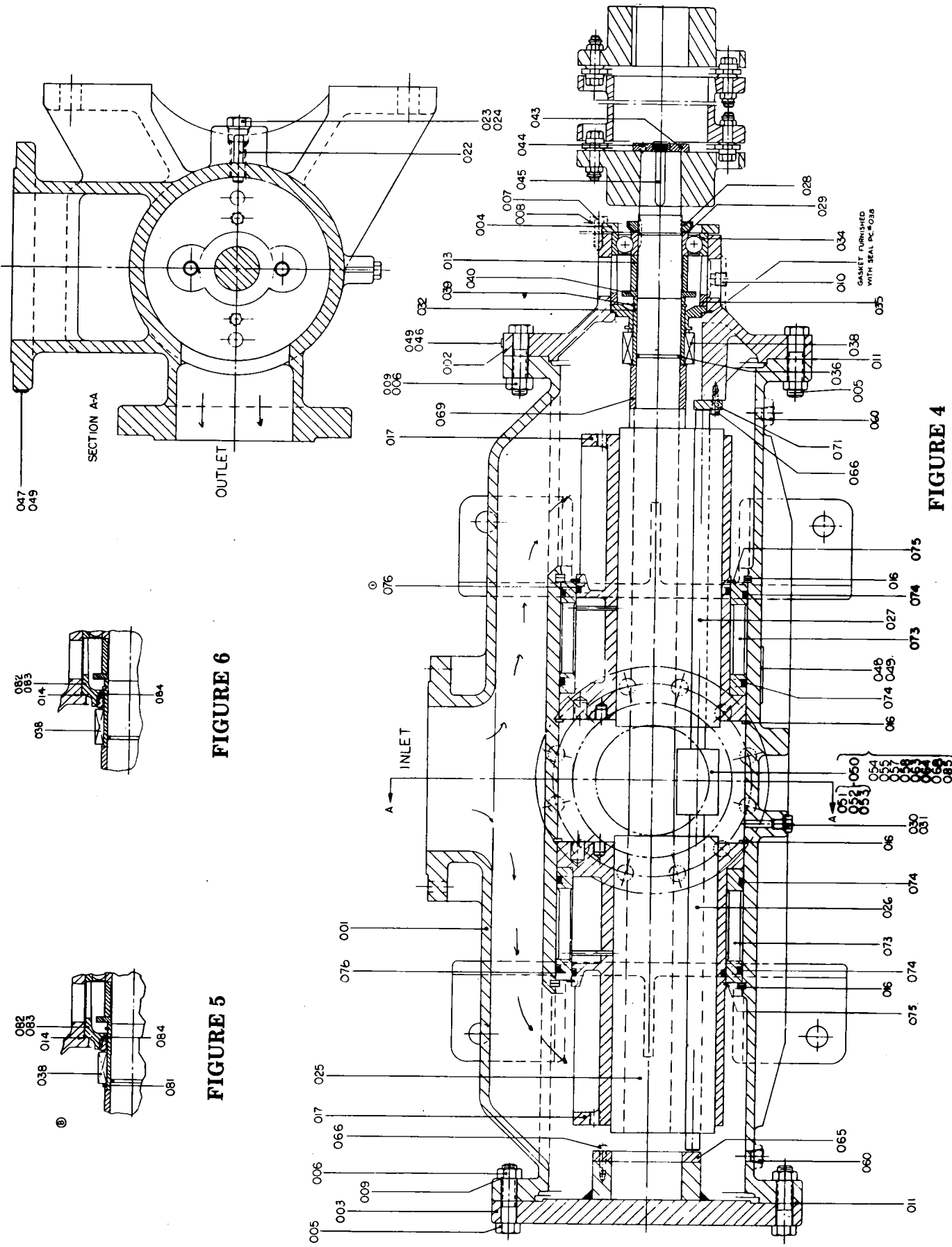
Part Number	Description	Part Number	Description
001	Case	040	Slinger
002	Cover	043	Check Nut
003	Cover	044	Setscrew
004	Retainer	045	Key
005	Bolt (16)	046	Nameplate
006	Nut (16)	047	Nameplate
007	Bolt (4)	048	Nameplate
008	Lockwasher (4)	049	Drive Screw (4)
009	Lockwasher (16)	050 (2) (3)	Seat Subassembly (4)
010	Plug	051 (2) (3)	Seat
011	(1) Gasket (2)	052 (2) (3)	Bushing
012	Drive Screw (3)	053 (2) (3)	Seat
013	Spacer	054 (2) (3)	Sleeve
014 (1)	Gasket	055 (2) (3)	Nut (4)
015	Seat Subassembly	057 (2) (3)	Pipe Plug (2)
016 (2)	Spiral Ring (6)	058 (2) (3)	Washer (4)
017	(2) Housing (2)	060	Plug (2)
018	Spring Pin	063 (2) (3)	Setscrew (4)
022 (2)	Stop Pin (2)	064 (2) (3)	Retainer (4)
023 (1)	O-ring (2)	065 (2)	Stop
024	Plug (2)	066	Capscrew (8)
025 (2)	Power Rotor	068 (2) (3)	Capscrew (16)
026 (2) (3)	Idler Rotor (2)	069	Spacer
027 (2) (3)	Idler Rotor (2)	071 (2)	Stop (2)
028 (2)	Bearing Locknut	073	Sleeve (2)
029 (2)	Bearing Lockwasher	074 (1)	O-ring (4, figure 4)
030	Plug	074 (1)	O-ring (2, figure 7)
031	O-ring	075 (2)	Spiral Ring (2)
032 (2)	Sleeve	076 (1)	O-ring (2)
034 (1)	Bearing	080	Spacer (2)
035	Spacer (figure 4)	081	Spacer
035	Seat (figure 7)	082	Seat Subassembly
036 (1)	O-ring	083	Seat
038 (1)	Seal	084	Spring Pin
039 (1)	Spiral Ring	085 (2) (3)	Cotter Pin

(1) Minor Repair Kit items.

(2) Major Repair Kit items. Items marked (1) also included in Major Repair Kit.

(3) Items furnished as an assembly. Cannot be purchased separately.

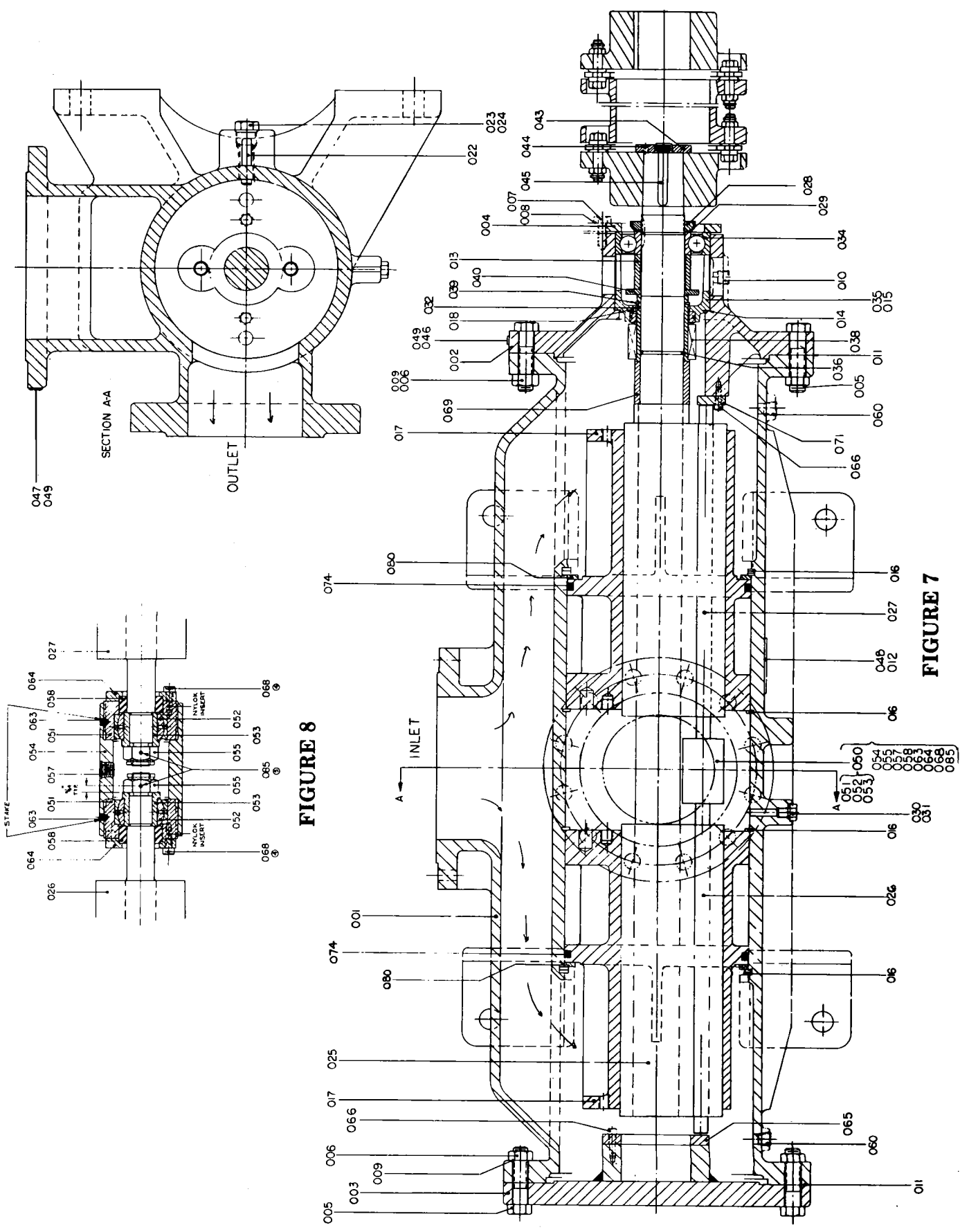
Quantities are one (1) except when noted in parentheses after description.



**FIGURE 4**

**FIGURE 5**

**FIGURE 6**



**FIGURE 8**

**FIGURE 7**