



Product Service Manual

For

AA3G Series Pumps

Size 187 Through 250



WARNING

The IMO General Installation Operation, Maintenance and Troubleshooting Manual, (No. SRM00046), this manual, and associated component manuals supplied with the unit should be read thoroughly prior to pump installation, start-up, operation, maintenance or troubleshooting.

Manual No. SRM00074

Rev. 05 (14-0090)

February 2014



READ THIS ENTIRE PAGE BEFORE PROCEEDING.

FOR SAFETY OF PERSONNEL AND TO PREVENT DAMAGE TO EQUIPMENT, THE FOLLOWING NOMENCLATURE HAS BEEN USED IN THIS MANUAL:

	DANGER	Failure to observe the precautions noted in this box can result in severe bodily injury or loss of life.
---	---------------	--

	WARNING	Failure to observe the precautions noted in this box can cause injury to personnel by accidental contact with the equipment or liquids. User should be provided protection to prevent accidental contact.
---	----------------	---

	CAUTION		ATTENTION	
Failure to observe the precautions noted in this box could cause damage or failure of the equipment.				

Non compliance of safety instructions identified by the following symbol could affect safety for persons:	Safety instructions where electrical safety is involved are identified by:	Safety instructions which shall be considered for reasons of safe operation of the pump and/or protection of the pump itself are marked by the sign:
		ATTENTION

CONTENTS

SAFETY AND TABLE OF CONTENTS.....	2
GENERAL INSTRUCTIONS, INTRODUCTION, MODEL DESIGNATORS	3
DESCRIPTION of EQUIPMENT	4
ORDERING INSTRUCTIONS & OPERATION	4
PARTS LIST, INPECTION & MAINTENANCE	5
PUMP DISASSEMBLY	6
PUMP REASSEMBLY	8
INSTALLATION, ALIGNMENT & TROUBLESHOOTING.....	9
FIELD & FACTORY SERVICE & PARTS.....	9
ASSEMBLY DRAWING	10, 11
Imo PUMP SALES OFFICE.....	12

DESCRIPTION OF EQUIPMENT

The AA3G Series pumps are positive displacement, rotary screw pumps consisting of a precision bored housing that encloses a drive screw (power rotor) and two intermeshing driven screws (idler rotors). These screws, when rotating, form a succession of closures or cavities. As they rotate, fluid is moved axially from inlet to outlet port in a continuous, uniform flow with minimum fluid pulsation and pump noise.

ORDERING INSTRUCTIONS

To order replacement pump or parts, contact an Imo sales office or representative with pump model number, serial number and part IDP number. This information can be found on pump nameplate and in this manual.

OPERATION

LIQUID LIMITATIONS

Never operate on water. Pump is designed for liquids having general characteristics of lubricating oil or distillate fuel oils.

OPERATING LIMITS

CAUTION	ATTENTION
<p>Operating conditions, such as speed, fluid viscosity, temperature inlet pressure, discharge pressure, filtration, duty cycle, drive type, mounting, etc., are interrelated. Due to these variable conditions, specific application limits may be different from operational limitations. This equipment must not be operated without verifying system's operating requirements are within pump's capabilities.</p>	

Under no circumstances are operating and structural limits (specified in Table 1) to be exceeded without specific approval from Imo Pump.

Table 1. Pump Operating and Structural Limits

MAXIMUM SPEED:	4000 RPM for 187/200 models and 3600 RPM for 250 models.
VISCOSITY:	15000 SSU (3200 cSt) Max./ 1500 SSU (325 cst) Max. for Relief Valve models. 2.0 cst Minimum For All Models
NOTE:	Consult factory for allowable operating viscosity at specific speeds and pressures. DO NOT alter design viscosity without prior consultation with Imo Pump.
TEMPERATURE:	0° to 225° F (-18° to 107° C).
INLET PRESSURE:	50 psig (3.4 Bar) Max.
DIFFERENTIAL PRESSURE:	250 psig (17.2 Bar) Max.
DISCHARGE PRESSURE:	300 psi (20.7 Bar) Max.
DRIVE:	Direct Drive only.
FILTRATION:	See General Installation Manual, CA-1
MOUNTING:	Foot or Flange Mounted.
SHAFT ROTATION:	Available in CW or CCW versions. Pump is NOT bi-rotational.

Models with Internal Relief Valves (Not available on Steel Version).

ATTENTION

The optional built-in relief valve is intended for momentary protection of pump against overpressure. It is not intended to be a pressure or flow control device. Continuous bypass of pumped liquid through this valve will cause the liquid to heat up very rapidly. Excessive temperature rise will damage pump.

	<div style="border: 1px solid black; padding: 5px; display: inline-block;">DANGER</div>	
<p>Relief valves are pre-set at factory. <u>DO NOT TAMPER WITH RELIEF VALVE.</u> Tampering with relief valve will void pump warranty and can cause bodily injury or loss of life. If relief valve must be adjusted, return pump to factory.</p>		

PARTS LIST TABLE

Table 2. Pump Parts List.

IDP	QTY	DESCRIPTION
1	1	Housing
2	1	Inlet Cover
3	8	Bolt
4	1	Inboard Cover
7	1	Shaft
8	2	Idler Rotor
11X	1	Ball Bearing
13	1	Key
15X	1	Retaining Ring

IDP	QTY	DESCRIPTION
16X	1	Seal
19X	1	Break Down Bushing (Steel Pumps Only)
20	1	Foot Mount Plate (Foot Mt. Pumps Only)
21	4	Bolt (Foot Mt. Pumps Only)
26X	1	Inlet Cover O-Ring
31X	1	Inboard Cover O-Ring
47	1	Pipe Plug ((2) on Weep Hole Pumps)
95	1	Pin

X = Minor Repair Kit Item

INSPECTION

The interval for inspection and replacement of worn parts varies with properties of pumped liquid and can only be determined by experience. All internal parts of 3G Series pumps are lubricated by pumped fluid. Pumping liquid that contains abrasive materials or liquid that is corrosive will significantly reduce service life and call for shorter service intervals. A worn pump will be noticeable by excessive vibration, noise, reduction in flow output and/or reduction in system pressure.

PUMP MAINTENANCE

	<div style="border: 1px solid black; padding: 5px; display: inline-block;">WARNING</div>	
<p>Failure to observe precautions while installing, inspecting, and maintaining pump can cause injury to personnel from accidental handling, e.g.: Liquids that may harm skin or clothing, fire hazard risks from flammable liquids, or injury from high pressure fluid jets</p>		



DANGER

BEFORE working on equipment, be sure all power to equipment is disconnected and locked-out.

GENERAL COMMENTS

Part number identifiers (IDPs) contained in Table 2 and shown within parenthesis such as “(8)” refer to circled numbers shown on Assembly Drawing.

NOTE: If upon disassembly, significant wear on power or idler rotors or rotor housing is found, Imo Pump recommends replacement of entire pump.

TOOLS REQUIRED.

The procedures described in this manual require common mechanics hand tools, an arbor press, a torque wrench and a suitable lifting device such as a sling for smaller pumps or a strap for larger models.

PUMP DISASSEMBLY

See seal drawings (Figures 2 and 3) and assembly drawings (Figures 4 and 5)



CAUTION

ATTENTION

Fluid leakage from disassembly of pump may make floor slippery and cause personal injury.

The following steps are required before starting any maintenance action:

- A) De-energize and lock out power to driver and tag power control box “**WARNING - OUT OF SERVICE**”.
- B) Close all inlet and outlet valves and tag valves “**WARNING - OUT OF SERVICE**”.
- B) Vent pressure from pump and drain pumping liquid.
- C) Remove pipe fittings/flanges at pump inlet and outlet openings.
- E) Remove bolts holding pump to its mounting.
- F) Remove coupling hub and key (13) from power rotor (7) shaft and locate pump on a suitable workbench.

NOTE: The 3G Series pumps incorporate highly finished precision parts that must be handled carefully to avoid damage to critical machined surfaces. Parts removed should be tagged for identification and their exact positions in pump carefully noted so that new or remove parts can be properly replaced.



CAUTION

ATTENTION

When removing inboard cover (4) from pump in step 1, below, **DO NOT** pull out rotors (7 & 8) They may drop to floor and be damaged. If rotors start to come out, hold them in place.

1. Remove bolts (3) from inboard cover (4) and then remove inboard cover (4) from pump housing (1).
2. Remove stationary seat {16B} of seal (16), on pumps with seals, and O-ring (31) from inboard cover (4).



CAUTION

ATTENTION

In next step, the rotors will be removed from pump. They will come out as a unit. Use care to support rotor set as it is withdrawn from housing so the idlers will not be dropped on floor

3. Remove power rotor (7) and idlers (8) by grasping shaft of power rotor and easing it out of housing (1). Set rotors aside.
4. For Elastomeric Bellows Type Seals (see Fig 2 below) – Slide rotating assembly {16A} of mechanical seal off of power rotor (7) with rotating motion.
5. For Metal Bellows Type Seals (see Fig 3 below) – Loosen set screw {16C} and slide rotating assembly {16A} from power rotor (7).

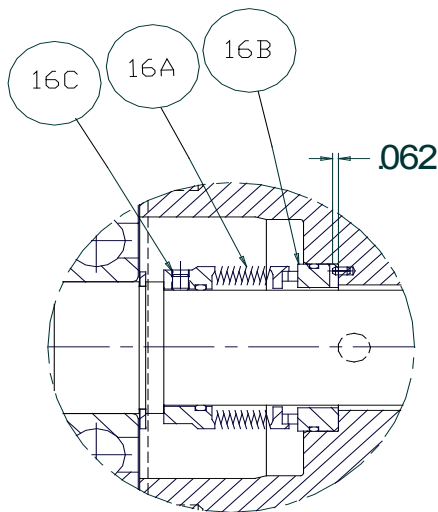

METAL BELLOWS MECHANICAL SEAL

Figure 3

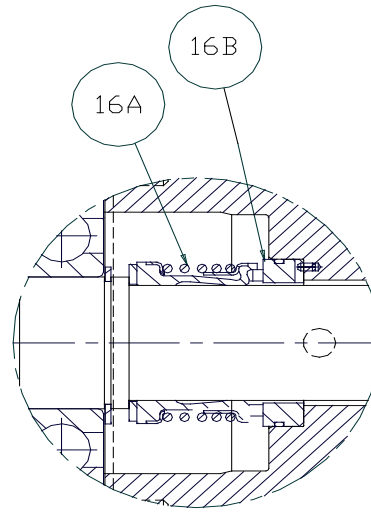

Elastomeric Bellows
Mechanical Seal w/Spacer

Figure 2

NOTE: If only replacing seals, pump disassembly is complete. For mechanical seal installation, complete steps 3 through 12 in reassembly procedure. If remainder of pump needs to be disassembled, proceed below.

6. Remove ball bearing (11) from power rotor (7) by first removing retaining ring (15) from groove in power rotor (7) shaft. Ball bearing (11) can then be removed with a gear puller or arbor press.

CAUTION

Removal of bearing by force applied to its outer ring could damage bearing.

NOTE: Imo Pump strongly recommends replacing ball bearing each time it's pressed off power rotor.

7. Note inlet cover (2) indexing. Remove inlet head (2) by removing four bolts (3).
8. Remove O-ring (26) from inlet head (2).
9. If steel pump, remove break down bushing (19) from inboard cover (4).

PUMP REASSEMBLY:

See seal drawings (Figures 2 and 3) and assembly drawings (Figures 4 and 5)

NOTE: Prior to pump assembly, all parts should be cleaned and inspected for nicks, burrs or gouges. When ready for assembly, wipe all parts, including bolts, O-rings and seal faces with clean, lubricating oil or pumped product, if applicable.

CAUTION

Bearing service life could be significantly reduced if bearing is pushed on by its outer race.

1. Install ball bearing (11) onto shaft (7) using an arbor press and sleeve by pushing on ball bearing (11) inner race only until ball bearing (11) is positioned against shoulder on power rotor (7).
2. Install retaining ring (15) in groove in power rotor (7).
3. Before installing seal (16), insure power rotor (7) shaft is clean and has no burrs or sharp edges.
4. **If seal has elastomeric rubber bellows, (see figure 2),** apply light film of oil to bore of bellows and install rotating assembly {16A} on power rotor (7) shaft with a twisting motion by pushing on seal retainer only with fingers. Do not touch carbon face with fingers. Clean carbon face of seal with alcohol and lint free cloth. Apply light film of clean lubricating oil to carbon face.
5. **If seal is metal bellows type, (see figure 3),** apply a light film of oil to rotating seat O-ring of seal and slide rotating assembly {16A} on power rotor shaft (7). Tighten setscrews {16C} Do not touch carbon seal face with fingers. Clean carbon face of seal with alcohol and lint free cloth. Apply light film of clean lubricating oil to carbon face.
6. Apply light film of clean lubricating oil on seat and O-ring of stationary seat {16B} of mechanical seal. Install stationary seat {16B} into bore in inboard cover (4) with fingers (do not touch seal face with any tools) so slot in face of seal is facing into inboard cover (4). Be sure stationary seat {16B} is all the way to bottom of bore in inboard cover (4) and slot in seal mates up to pin (95) in inboard cover (4).
7. Clean stationary seat of mechanical seal (16A) in inboard cover (4) with alcohol and soft, lint free cloth, and apply light film of clean lubricating oil to carbon face.

8. Mesh two idler rotors (8) and power rotor (7) together into a rotor assembly making sure idler rotors and balance piston are properly engaged.
9. Install rotors by positioning pump housing in a vertical position and sliding rotor assembly into housing bore (1) until ball bearing (11) bottoms out in housing bore.
10. Install O-ring (31) in groove in inboard cover (4).
11. If steel pump, install break down bushing (19) in inboard cover (4).
12. Install inboard cover (4) on housing being sure that inboard cover (4) is kept square with power rotor shaft.
13. Install four bolts (3) into inboard cover (4) and thread bolts into housing (1). Torque bolts to values shown on assembly drawing.
14. Install O-ring (31) in groove in inlet head (2).
15. Install inlet head (2) onto housing (1) with cap screws (3).
16. Installing key (13) into power rotor (7) keyway and coupling on shaft (7).

INSTALLATION, ALIGNMENT AND TROUBLESHOOTING

Install coupling to driver shaft and align pump and driver as detailed in the Installation Manual, CA-1.

After pump is connected to piping and inlet and outlet valves are open, be sure to vent air from seal chamber before starting pump by opening pipe plug at inboard end of pump until oil comes out. This will assure seals are lubricated at startup.

For detailed instructions regarding installation, alignment, operation and trouble shooting, see General Installation, Operation, Maintenance & Troubleshooting Manual, CA-1.

FIELD AND FACTORY SERVICE AND PARTS

Imo Pump maintains a staff of trained service personnel that can provide pump installation, pump start-up, maintenance/overhaul and troubleshooting supervision as well as installation and maintenance training.

Our factories provide maintenance as well as overhaul and test facilities in the event user prefers to return pumps for inspection or overhaul. Pumps that have been factory-overhauled are normally tested and warranted "as-new" for a period of one year from date of shipment.

For either field service or factory overhaul assistance, contact your local Imo Sales Office or representative at the Technical/Customer Service Department in Monroe, NC, USA.

Most pumps have minor repair kits available. Minor Repair Kits are used to repair leaking seals, bad bearings and/or for re-assembly after pump tear-down. They include (as applicable) pump shaft seals, packing, all gaskets/O-rings and bearings. Since kits have all the necessary parts, it is preferred that they be purchased rather than selecting individual parts. When parts are individually selected from Parts List, some needed components are often overlooked. In addition, mixing worn or used parts with new parts risks rapid wear and shortened service life from new parts.

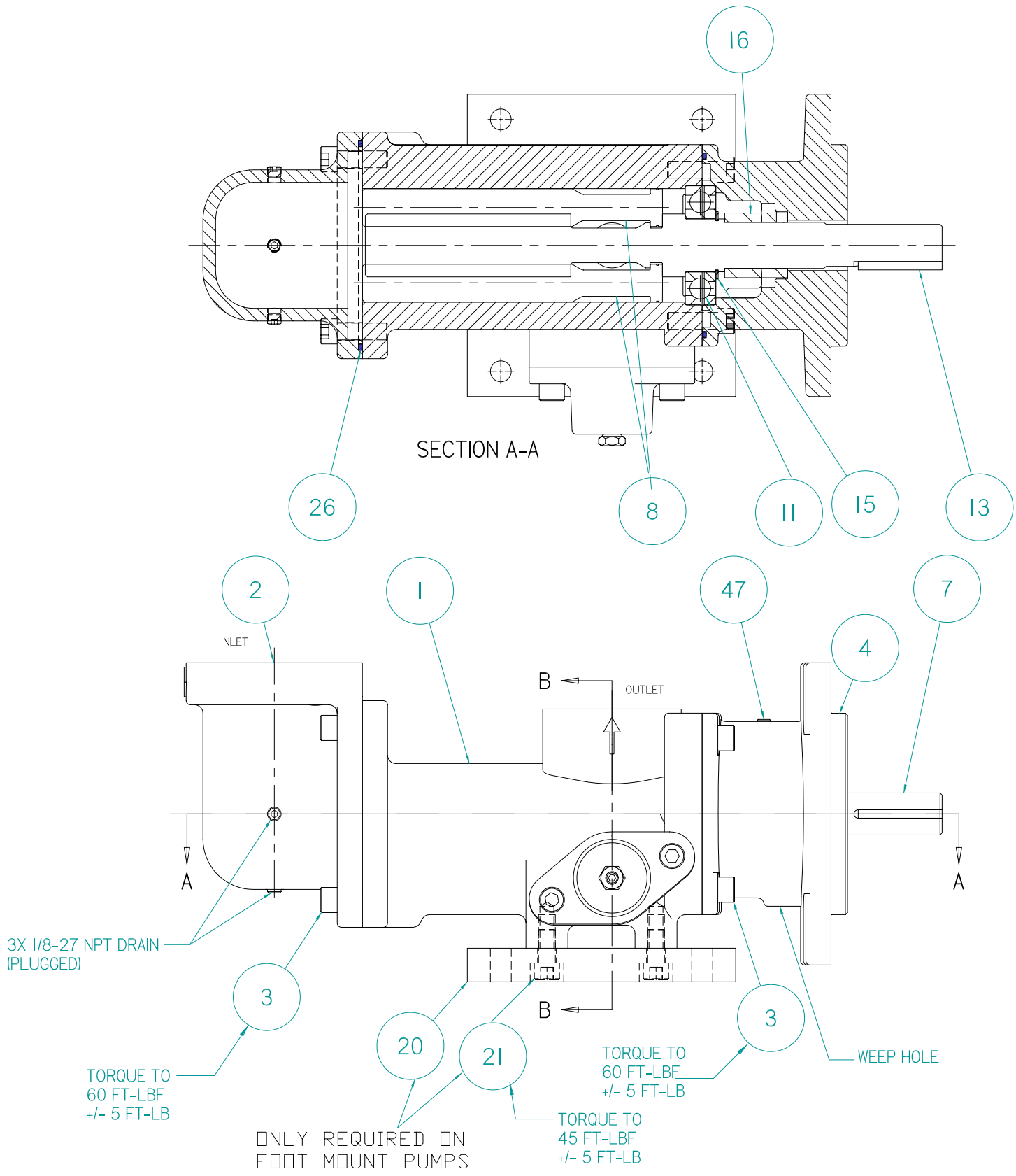

Fig 4 - IRON PUMP ASSEMBLY

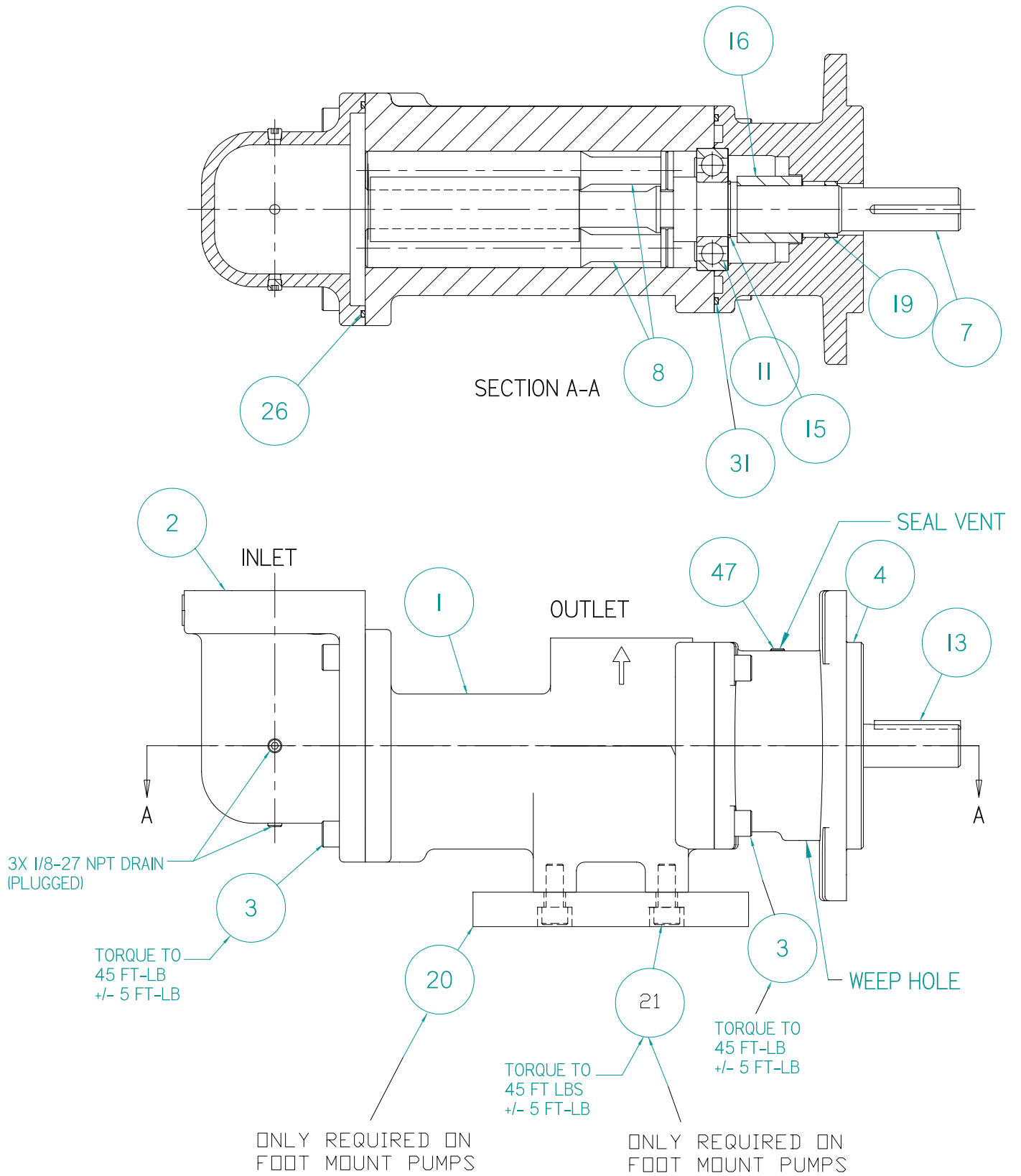
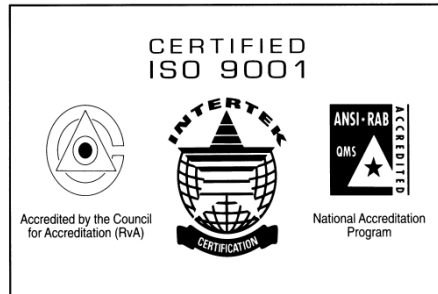

Fig 5 - Steel Pump Assembly

IMO Pump
1710 Airport Road -28110
PO Box 5020
Monroe, NC/USA 28111-5020
Tel: 1+(704) 289-6511
+1.877.853.7867
Fax: 1+(704) 289-9273
Email: imo.pump@colfaxcorp.com
Web: www.imo-pump.com



COLFAX
Fluid Handling

© 2012 Colfax Fluid Handling all rights reserved.

ALLWEILER® COT-PURITECHSM HOUTTUINTM IMO® LSCSM ROSSCOR® TUSHACO® WARREN®