

COLFAX

Fluid Handling

PRODUCT SERVICE MANUAL

FOR

G3D _-350 and 400 SERIES PUMPS (Idler Cup and Hydrostatic Thrust Designs)



WARNING

The Imo General Installation Operation, Maintenance, and Troubleshooting Manual, (No. SRM00046), as well as all other component manuals supplied with these type units should be read thoroughly prior to pump installation, start-up, operation, maintenance or troubleshooting.

Manual No. SRM00080

Rev. 04 (13-0321)

September 2013

Imo Pump

1710 Airport Road
PO Box 5020
Monroe, NC USA
28111.5020

Tel: +1.704.289.6511

Email: cc@colfaxcorp.com

Web: colfaxcorp.com

ALLWEILER® COT-PURITECHSM HOUTTUINTM IMO® LSCSM ROSSCOR® TUSHACO® WARREN®

IMPORTANT NOTE

The importance of seal chamber priming cannot be overemphasized. Due to the prevalence of seal damage and leakage caused by not filling the seal chamber with liquid before putting a pump in service, this page is located at the beginning of this document.

SEAL CHAMBER PRIMING

Fill mechanical seal chamber with liquid to insure seal does not start dry. This can be done by removing seal vent set-screw and pouring liquid into vent passageway before opening pump inlet. Alternately, seal chamber can be vented in situations where inlet pressure is above atmospheric by opening inlet and discharge valves and then loosening seal vent plug to allow positive inlet pressure to push air out of seal chamber until oil flows from it. **See figure below.**

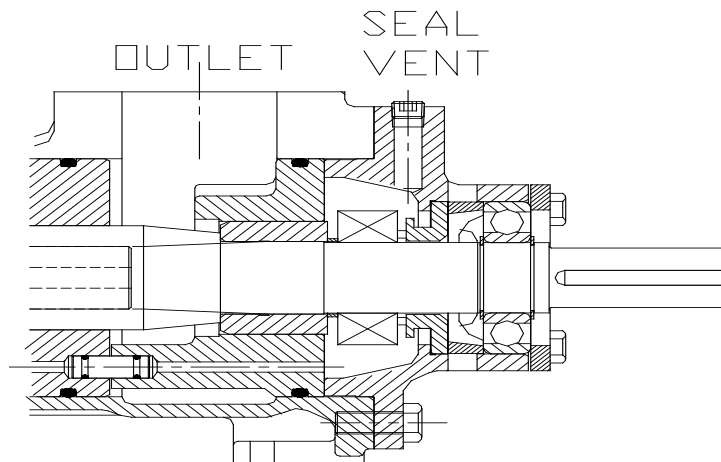





Filling or Venting Seal Cavity Using Seal Vent

CAUTION

Failure to fill or vent seal chamber as described above may cause damage to seal running faces which may result in seal leakage.

READ THIS ENTIRE PAGE BEFORE PROCEEDING

FOR SAFETY OF PERSONNEL AND TO PREVENT DAMAGE TO EQUIPMENT, THE FOLLOWING NOMENCLATURE HAS BEEN USED IN THIS MANUAL:

	DANGER		
Failure to observe precautions noted in this box can result in severe bodily injury or loss of life.			
	WARNING		
Failure to observe precautions noted in this box can cause injury to personnel by accidental contact with equipment or liquids. Protection should be provided by user to prevent accidental contact.			
CAUTION		ATTENTION	
Failure to observe precautions noted in this box can cause damage or failure of equipment.			
Non compliance of safety instructions identified by the following symbol could affect safety for persons: <div style="text-align: center;"></div>	Safety instructions where electrical safety is involved are identified by: <div style="text-align: center;"></div>	Safety instructions which shall be considered for reasons of safe operation of pump and/or protection of pump itself are marked by the sign: <div style="text-align: center;">ATTENTION</div>	
ATTENTION			
If operation of pump is critical to your business, we strongly recommend you keep a spare pump or major repair kit in stock at all times. As a minimum, a minor repair kit (o-rings, gaskets, shaft seal and bearings) should be kept in stock so pump refurbishment after internal inspection can be accomplished.			

CONTENTS

Seal Chamber Priming.....	2
Safety and Table of Contents.....	3
A. General Instructions.....	4
B. Introduction.....	4
C. Description of Equipment.....	4
D. Pump Model Identification.....	5
E. Ordering Instructions.....	5
F. Operation.....	6
G. Parts List and Noise Levels.....	7 thru 8
H. Pump Maintenance and Seal Drawing.....	8 thru 13
I. Troubleshooting.....	14
J. Field and Factory Service and Parts.....	14
K. Assembly Drawings.....	15 thru 18

A. GENERAL INSTRUCTIONS

Instructions found herein cover disassembly, assembly and parts identification of _G3D_-350 and 400 series pumps. Both original design with idler cups and newer design with hydrostatic idlers are covered where applicable.

NOTE: Individual contracts may have specific provisions that vary from this manual. Should any questions arise which may not be answered by these instructions, refer to Imo General Installation Operation, Maintenance, and Troubleshooting Manual, SRM00046, provided with your order. For further detailed information and technical assistance please refer to Imo Pump, Technical/Customer Service Department, at (704) 289-6511.

Manual cannot possibly cover every situation connected with installation, operation, inspection, and maintenance of equipment supplied. Every effort was made to prepare text of manual so that engineering and design data is transformed into most easily understood wording. Imo Pump must assume personnel assigned to operate and maintain supplied equipment and apply instruction manual have sufficient technical knowledge and are experienced to apply sound safety and operational practices which may not be otherwise covered by this manual.

In applications where equipment furnished by Imo Pump is to become part of processing machinery, these instructions should be thoroughly reviewed to ensure proper fit of said equipment into overall plant operational procedures.



WARNING

If installation, operation, and maintenance instructions are not correctly and strictly followed and observed, injury to personnel or serious damage to pump could result. Imo Pump cannot accept responsibility for unsatisfactory performance or damage resulting from failure to comply with instructions.

B. INTRODUCTION

This instruction manual covers series _G3D_-350 and 400 Imo pumps. This series of pumps has been designed for use in hydraulic, lubricating, seal, distillate, residual, fuel and crude oil applications. The model and design construction of each pump can be identified by the designator code on the pump nameplate. Definitions of model designators are identified in figure 1.

C. DESCRIPTION OF EQUIPMENT

G3D-350 and 400 Series pumps are positive displacement, rotary screw pumps consisting of a precision bored housing which encloses a driven screw (power rotor) and two intermeshing following screws (idler rotors). These screws when rotating form a succession of closures or cavities. As they rotate, fluid is moved axially from inlet port to outlet port in a continuous, uniform flow with minimum fluid pulsation and pump noise.

D. PUMP MODEL IDENTIFICATION

Instruction manual covers Imo Series _G3D-350 and 400 pumps. Model of each pump is identified on pump nameplate. Refer to figure 1 and table 1 for instructional keys when using manual.

Figure 1 – Model Designator Definitions

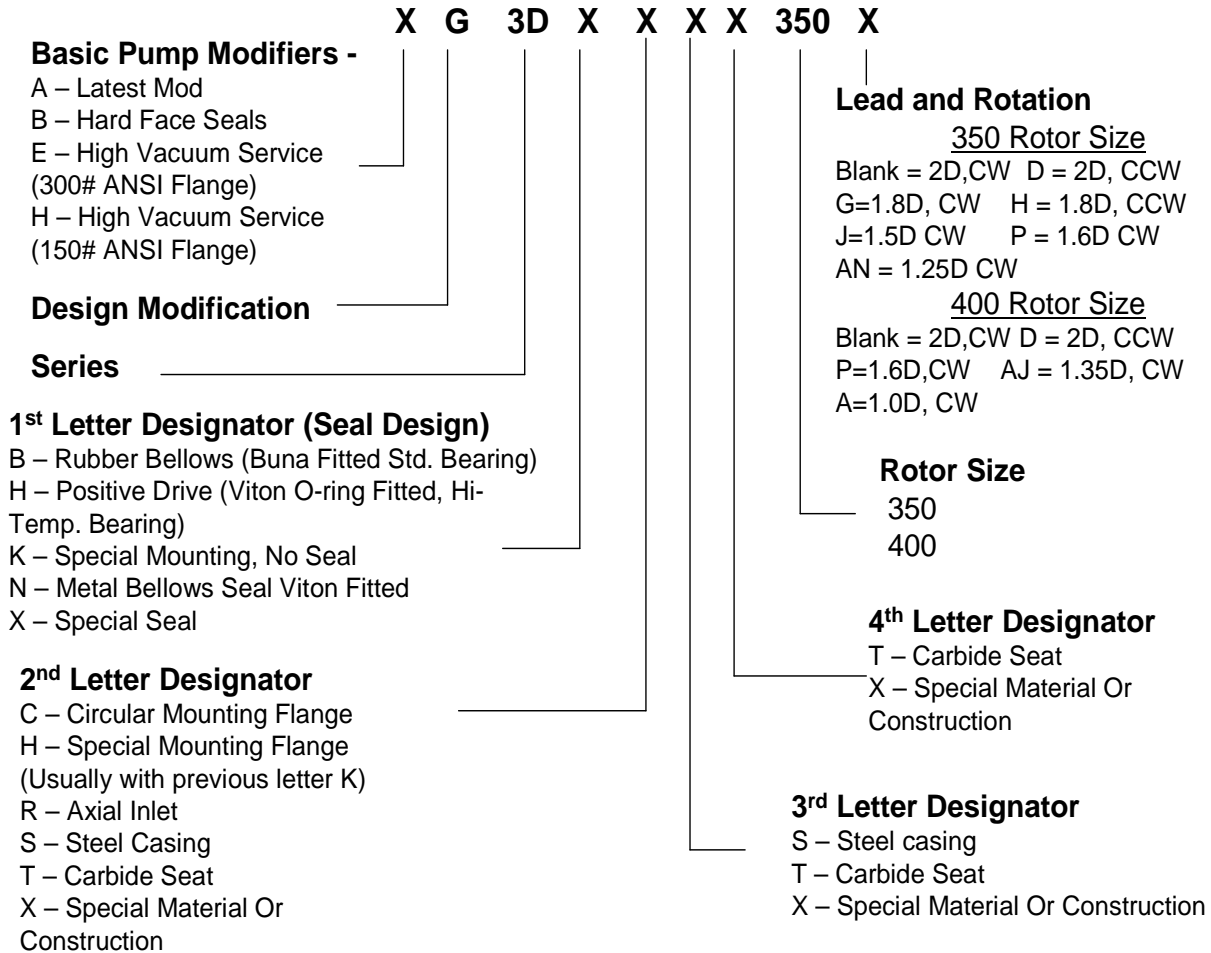

E. ORDERING INSTRUCTIONS

When corresponding with Imo Pump regarding Series _G3D_ _-350 and 400 series pumps, refer to pump nameplate, this instruction manual, and assembly drawing as instructed below:

1. From pump nameplate, record pump model number, serial number, and manufactured date.
2. Record instruction manual number, revision, and date.
3. From instruction manual, record figure numbers that apply to replacement part(s).
4. From assembly drawing or parts list (see table 2) provide IDP number(s) and names for replacement part(s).
5. Give above information to your Imo service representative.

Imo sales and service representatives are listed herein and in General Instruction Manual, SRM00046.

F. OPERATION

F.1 LIQUID LIMITATIONS

Never operate with thin liquids such as solvents or water. Pump is designed for liquids having general characteristics of oil.

F.2 OPERATING LIMITS

CAUTION	ATTENTION
<p>Operating conditions, such as speed, fluid viscosity, temperature, inlet pressure, discharge pressure, filtration, duty cycle, drive type, mounting, etc., are interrelated. Due to these variable conditions, specific application limits may be different from operational limitations. Equipment must not be operated without verifying system operating requirements are within pump's capabilities.</p>	

Under no circumstances are the following operating limits (specified in table 1) to be exceeded without specific approval from Imo Pump.

Table 1 – Normal Pump Operating and Structural Limits

Condition	Limit
Maximum Speed	2500 rpm
Minimum Viscosity	32 SSU
Maximum Viscosity (figure 1)	
1 st Letter Designator B	2500 SSU
1 st Letter Designator H	15000 SSU
Minimum Liquid Temperature	0°F
Maximum Liquid Temperature (figure 1)	
1 st Letter Designator B	180°F
1 st Letter Designator H	220°F
Maximum Inlet Pressure	50 psig
Maximum Discharge Pressure (Continuous Duty)	500 psig
Filtration	Refer to General Instruction Manual, CA-1
Drive	Direct or Belt
Mounting	Foot mounted in any attitude

F3 Airborne Noise Levels (dBA) –

F3a – Measuring Conditions

- Distance to Pump = 1 Meter
- Operation = Cavitation Free
- Tolerance ± 3 dB

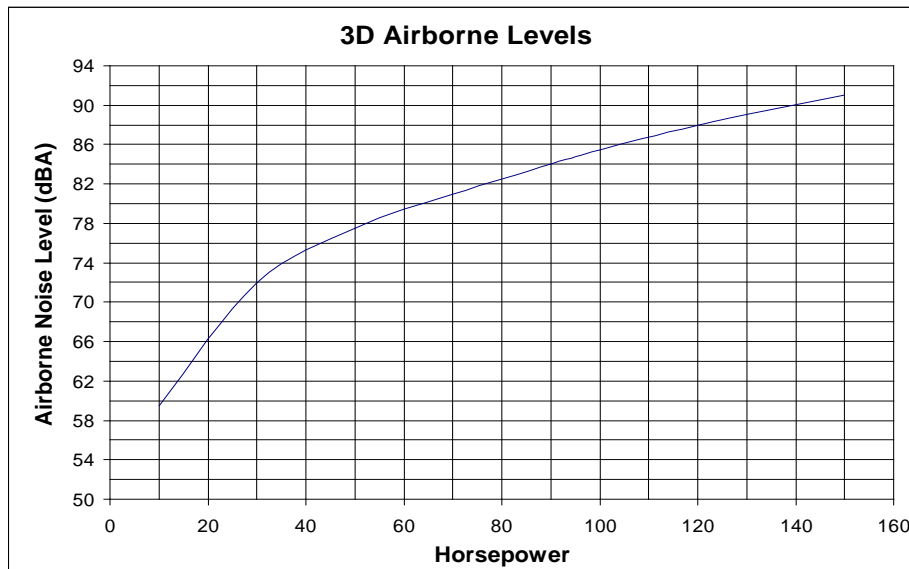

Figure 2 – Airborne Levels

G. PARTS LIST

Table 2 – _G3D_-350_Pump Parts List

IDP	QTY	DESCRIPTION	KIT	IDP	QTY	DESCRIPTION	KIT
1	1	Case		24	2	Washer	
2	1	Housing	XX	25	2	Mechanical Seal**	X
4	1	Anti-Rotation Tube		26	1	Inlet	
5	2	Tube O-rings	X	30	4	Washers (C-Face Only)	
6	2	Housing/Inboard Cover O-ring	X	32	2	Pipe Plug (Foot Mount Only)	
8	2	Gasket (1 on C-Face)	X	33	1	Balance piston Bushing (C-face pumps only)	XX
9	1	Inboard Cover		35	2	Pipe Nipple (C-Face Only)	
10	16	Hex Bolts		36	1	Pipe Coupling (C-Face Only)	
11	1	Power Rotor	XX	37	1	Tube Fitting (C-Face Only)	
13	2	Snap Rings	X	38	1	Seal Spacer *	
14	1	Spacer/Seal Seat Adapter	X	42	1	Tubing (C-Face Only)	
15	1	Bearing	X	43	1	Housing Spacer	
16	1	Key		44	1	Gasket (O-ring Seats Only)	X
17	1	Bearing Retainer		45	1	Fastener Seal	X
18	4	Bearing Retainer Hex Bolts		46	1	Pin Stop	XX
19	2	Idlers	XX	47	1	Balance Piston Housing (Not C-Face)	XX
20	2	Idler Cups (Idler Cup Design Only)	XX	57	1	90° Tube Fitting (C-Face Only)	
21	1	Thrust Plate	XX	88	1	Inlet O-ring (Axial inlet pumps only)	X
22	2	Thrust Spacer		92	16	Washers (C-Face Pumps Only)	
23	2	Hex Cap Screws					

X = Minor Repair Kit Items.
 XX = Major Repair Kit Items. (Items marked (X) are included in Major Repair Kit.)
 * = Not used in "DKH" pumps.

Table 3 – _G3D_-400_Pump Parts List

IDP	QTY	DESCRIPTION	KIT	IDP	QTY	DESCRIPTION	KIT
1	1	Case		43	1	Bearing Retainer	
2	1	Inlet		46	1	Inboard Cover	
4	8	Hex Bolt (Foot Mount Only)		47	4	Brg. Retainer Hex Bolts	
5	2	Pipe Plug (Foot Mount Only)		48	1	Bearing Spacer (J-Seat Seal and DKH Only)	
6	1	Pin Stop	XX	49	1	Bearing	X
7	1	Fastener Seal	X	50	1	Housing Spacer	
9	2	Gasket (1 for C-Face)	X	51	2	Thrust Spacer	
21	2	Idler	XX	52	2	Thrust Spring Lock Washer	
22	1	Balance Piston Housing (Foot Mount Only)	XX	53	2	Thrust Hex Bolt	
23	2	Cups	XX	54	8	Hex Bolts	
24	1	Rotor Housing	XX	63	1	Power Rotor	XX
25	1	Seal	X	64	1	Pipe Plug (Steel Only)	
26	1	Tube		71	1	Tubing (C Face Only)	
27	2	Tube O-ring	X	80	1	Seal Seat Adapter (O-ring Seat Seal only)	
28	2	Housing & Inboard Cover O-ring	X	83	1	Seal Gasket	X
29	1	Thrust Plate	XX	86	1	Power Rotor Balance Piston (C-Face Only)	XX
30	16	Washers (8 on C-Face)		79	2	90° Tube Fitting (C-Face Only)	
31	1	Key		88	1	Inlet O-ring (Axial inlet pumps only)	X
38	1	Seal Spacer*		95	8	Nuts (C-Face only)	
42	2	Retaining Ring	X				

X = Minor Repair Kit Items.
 XX = Major Repair Kit Items. (Items marked (X) are included in Major Repair Kit.)
 * = Not used in "DKH" pumps.

H. PUMP MAINTENANCE

	WARNING
<p>Failure to observe precautions while installing, inspecting and maintaining pump can cause injury to personnel from accidental handling of liquids that may harm skin or clothing, or fire hazard risks from flammable liquids, or injury from high pressure fluid jets.</p>	

	DANGER
<p>BEFORE working on equipment, make sure all power to equipment is disconnected and locked-out.</p>	

H.1 GENERAL COMMENTS

NOTE: Part number identifiers (IDP) contained within parenthesis, such as (9), refer to circled numbers shown in pump parts list Tables 2 and 3 and on assembly drawings (figures 3 through 7).

De-energize driver before starting with any maintenance action.

H.2 TOOLS REQUIRED

Procedures described in manual require common mechanics hand tools, a torque wrench, dial indicators for alignment and a suitable lifting device such as slings, straps, etc.

H.3 PUMP DISASSEMBLY PROCEDURES:

NOTE: _G3D_-350_ and 400 pumps incorporate highly finished precision parts that must be handled carefully to avoid damage to critical machined surfaces. Parts removed should be tagged for identification and their exact positions in pump carefully noted so new parts, or same parts, are properly replaced without damage.



CAUTION

Fluid leakage from disassembly of pump may make floor slippery and can cause personal injury

SPECIAL NOTE: To service mechanical seal and ball bearings ONLY perform H.3, Steps 1 through 5 and H.4, Steps 7thru 11 Only.

Determine pump model identification identified on pump nameplate to select applicable pump assembly shown in Figure 4 through 7. Refer to that assembly for following instructions.

1. Close suction and discharge piping to pump. Vent pressure from pump. Disconnect piping. Remove drain plugs (5 or 32) or seal tubing (35, 36, 57, 42, 71, 79) on C-face pumps, and drain unit. Remove pump from driver, coupling and base plate. Remove coupling hub and key (16 or 31).
2. Remove bearing retainer (17 or 43) from inboard cover (9 or 46) by removing bolts (18 or 47) (and lockwashers (30) if present).
3. Remove assembled power rotor (11 or 63) from inboard cover (9 or 46). Removal of power rotor (11 or 63) includes removal of snap rings (13 or 42), ball bearing (15 or 49), seal spacers (14 or 48), and mechanical seal (25).
4. Disassemble power rotor (11 or 63) as follows:
 - a. Using a flat nosed tool, such as a screw driver, remove snap rings (13 or 42) from groove in power rotor (11 or 63) on both sides of ball bearing (15 or 49).
 - b. Sealed ball bearing (15 or 49) is assembled to power rotor (11 or 63) with light press fit. Ball bearing (15 or 49) may be removed by using bearing puller or vertical arbor press. When using press, place two pieces of key stock through openings of mechanical seal seat adapter (14 or 48) underneath ball bearing (15 or 49) on both sides of power rotor shaft. Key stock should be long enough to support power rotor (11 or 63) as it is placed in press. Position press ram against power rotor (11 or 63) coupling end face. Gently press power rotor (11 or 63) through ball bearing (15 or 49). Ensure power rotor (11 or 63) does not fall to floor once ball bearing (15 or 49) is off of its diameter.
 - c. If pump has no seal (DKH design in figure 4 or 6), power rotor disassembly is complete. Remove spacer (14 or 48) and skip to step 6. If pump has mechanical seal, proceed with step (d).

For steps (d thru g), refer to figure 3, mechanical seal drawing.

- d. If stationary seal face is “J” type, remove spacer (14 or 48) and “J” type stationary seal seat from power rotor (11 or 63).
 - e. If seal is O-ring type, remove seal seat adapter (14 or 48) with stationary seal seat. Remove stationary seat with O-ring from seal seat adapter (14 or 48). Discard O-ring.
 - f. If single spring, rubber bellows seal, remove rotating seat from shaft (11 or 63), If multi-spring seal, disengage set screw and then remove rotating seal seat.
 - g. Remove spacer (38) from shaft.
5. Remove gasket (44 or 83) from inboard end cover (9 or 46).
 6. Remove inboard cover (9 or 46) by removing bolts (10 or 4) or nuts (95) if Size 400, C-face unit. Also remove washer (30 or 92) where applicable.
 7. Remove and discard gasket (8 or 9) from inboard cover (9 or 46) or O-ring (6 or 28) if pumps are C-face design.
 8. On C-flange pumps ONLY, press bushing (33 or 86) from cover (9 or 46). Cover may require heating to loosen Loctite before bushing (33 or 86) can be removed. Do not heat to more than 250°F.
 9. Remove inlet head (26 or 2) from case (1) by removing bolts (10 or 54) (and lockwashers (92 or 30) if present). Remove and discard gasket (8 or 9) or O-ring (88) from inlet head (26 or 2).
 10. Remove thrust plate (21 or 29) and spacers (22 or 51) by removing bolts (23 or 53) and lock washers (24 or 52)
 11. If idler cup design, remove cups (20 or 23) from idlers (19 or 21).
 12. Remove idlers (19 or 21) from housing (2 or 24) by unscrewing them from housing bores.

CAUTION

ATTENTION

Do not permit idlers (19 or 21) to drop as they emerge from housing (2 or 24).
--

13. Remove housing spacer (43 or 50) from case (1).
14. Remove pin stop (46 or 6) and fastener seal (45 or 7) from case (1).
15. If pumps are not C-face design, remove balance piston housing (47 or 22) with O-ring (6 or 28). This can be accomplished by pushing on suction end of housing (2 or 24) until balance piston (47 or 22) emerges.
16. Remove and discard balance piston O-ring (6 or 28).
17. Remove tube (4 or 26) with O-rings (5 or 27) from housing (2 or 24) or balance piston housing (47 or 22). Discard O-rings (5 or 27).

18. Remove housing (2 or 24) and O-ring (6 or 28) from inlet end of case (1). Discard O-ring (6 or 28).

H.5 PUMP ASSEMBLY

NOTE: Prior to assembly of pump, clean and inspect all parts for nicks and burrs. Replace all worn or damaged parts. Imo Pump recommends replacement of all O-rings (6, 28, 88), gaskets (8, 9, 44 or 83), mechanical seal (25) and ball bearing (15 or 49) when these parts are disturbed from their previously installed positions. Coat all parts with light lubricating oil to assist in assembly. Inspect power rotor (11 or 63) shaft and remove any nicks or burrs which are present. Polish power rotor shaft to remove any rust or oxidants that may be present under shaft sleeve.

1. Install O-ring (6 or 28) in groove in housing (2 or 24). Install O-rings (5 or 27) in grooves in tube (4 or 26) and install tube (4 or 26) in housing (2 or 24).
2. Install housing (2 or 24) O-ring end first, in pump case (1) from suction end until stop pin (46 or 6) slot is properly aligned. Install stop pin (46 or 6) with fastener seal (45 or 7) in case (1).
3. If pump is C-face version (Figure 5 and 7) proceed below. If pump is foot mount, skip to step 4:
 - a. Clean and dry inboard cover (9 or 46) and balance piston bushing (33 or 86) mating surfaces with solvent. Wipe Loctite "T747" Primer or equivalent onto the mating surfaces of bushing (33 or 86) and inboard cover (9 or 46). Allow 1 to 5 minutes until primer is visibly dry. Apply Loctite 609 or equivalent to bushing (33 or 86) and inboard cover (9 or 46) mating surfaces. Assemble bushing (33 or 86) into inboard cover (9 or 46). Allow 10 minutes to dry before proceeding with assembly.
 - b. Install O-ring (6 or 28) on inboard cover. Install inboard cover (9 or 46) into discharge port side of case (1) using bolts (10 or 95) (and lock washers (92 or 30) if present). Ensure seal vent (57 or 5) is facing up and pin (4 or 26) in housing mates with hole in inboard cover (9 or 46). Torque bolts (10 or 95) to value on assembly. Skip to step 7.
4. Install O-ring (6 or 28) on balance piston housing (47 or 22).
5. Install balance piston housing (47 or 22) in case (1) lining up hole in balance piston housing (47 or 22) with pin (4 or 26) in rotor housing (2 or 24).
6. Install gasket (8 or 9) on inboard cover (9 or 46).
7. Install inboard cover (9 or 46) into discharge port side of case (1) using bolts (10 or 4) (and lockwashers (92 or 30) if present). Ensure seal vent (32 or 5) is facing up. Torque bolts (10 or 4) to value on correct assembly drawing.
8. Assemble power rotor (11 or 63) and mechanical seal (25) as follows:

Note: If no mechanical seal (DKH design in figure 4 and 6), assembly spacer (14 or 48) in inboard cover (9 or 46) and skip to step (f) below. If pump has mechanical seal proceed with step (a) below.

- a. Assemble spacer (38) onto shaft (11 or 63).

For steps (b) – (e), refer to figure 3, mechanical seal drawing.

- b. If seal is a single spring type rubber bellows type, apply light coat of system fluid to inside diameter of bellows and slide mechanical seal rotating assembly on power rotor (11 or 63) until it seats against the shoulder of seal spacer (38). Wipe seal face with isopropyl alcohol and a lint free rag.
- c. If seal is a multi-spring seal, coat O-ring inside of rotating seat with system fluid and slide mechanical seal rotating assembly on power rotor (11 or 63) until it seats against the shoulder of seal spacer (38). Tighten rotating seat set screw. Wipe seal face with isopropyl alcohol and a lint free rag.
- d. If seal has a “J” type seat, clean it with isopropyl alcohol and a lint free rag. Then put a small amount of clean system fluid or light oil on its running face and install the running face against the stationary seat face.
- e. If seal has O-ring type stationary seat, install O-ring in groove of mechanical seal stationary seat. Install seat including O-ring in seal seat adapter (14 or 48) ensuring that groove in back of stationary seat mates to spring pin in seal seat adapter (14 or 48). Clean seal face with isopropyl alcohol and a lint free rag. Put a small amount of clean system fluid or light oil on seal running face. Install the rotating ring running face against the stationary seat face.
- f. Install inner snap ring (13 or 42) in groove of power rotor (11 or 63).
- g. Press bearing (15 or 49) on power rotor (11 or 63), pressing only on inner race of ball bearing (15 or 49) using an installation sleeve until it is located next to inner snap ring (13 or 42).

CAUTION	ATTENTION
Ball Bearing (49) will be damaged if installed by pressing on outer race.	

- h. Install outer snap ring (13 or 42) in groove of power rotor (11 or 63).
- 9. Install gasket (44 or 83) in inboard cover (9 or 46). Gasket may come with replacement seal. Gasket (44 or 83) not required with DHK pump (see assembly drawings 4 and 6)
- 10. Install assembled power rotor (11 or 63) in pump, centering all parts as they enter inboard cover (9 or 46). Align one of openings in spacer (14 or 48) over drain in inboard cover (9 or 46).
- 11. Install bearing retainer (17 or 43) on inboard cover (9 or 46) using bolts (18 or 47) (and lockwashers (30) if present). Torque bolts (18 or 47) to value on assembly drawing
- 12. Install idlers (19 or 21) into housing (2 or 24) by meshing threads with power rotor thread.
- 13. If idler cup design, install cups (20 or 23) on idlers (19 or 21).
- 14. Install spacer (43 or 50) on suction end of case (1) flush with edge of housing (2 or 24).
- 15. Install bolts (23 or 53) and lock washers (24 or 52) in thrust plate (21 or 29). Install spacers (22 or 51) on bolts (23 or 53).

16. Install thrust plate assembly including thrust plate (21 or 51), washers (24 or 52), bolts (23 or 53) and spacers (22 or 51) on housing (2 or 24). Torque bolts (23 or 53) to value on correct assembly drawing.
 17. Install gasket (8 or 5) or O-ring (88) in groove in inlet head (26 or 2).
 18. Install inlet head (26 or 2) using bolts (10 or 4) (and lockwashers (92 or 30) if present). Torque bolts to value on correct assembly drawing.
- NOTE:** Inlet head (26 or 2) can be rotated and repositioned in 90 degree increments to suit suction piping. To change inlet position remove bolts (10 or 54) and rotate inlet head to desired position. Install bolts (10 or 54) and torque to proper values indicated on assembly drawing.
19. Install coupling hub key (16 or 31). Install and align pump and driver as specified in General Instruction Manual, SRM00046.

FIGURE 3 – MECHANICAL SEAL DRAWING

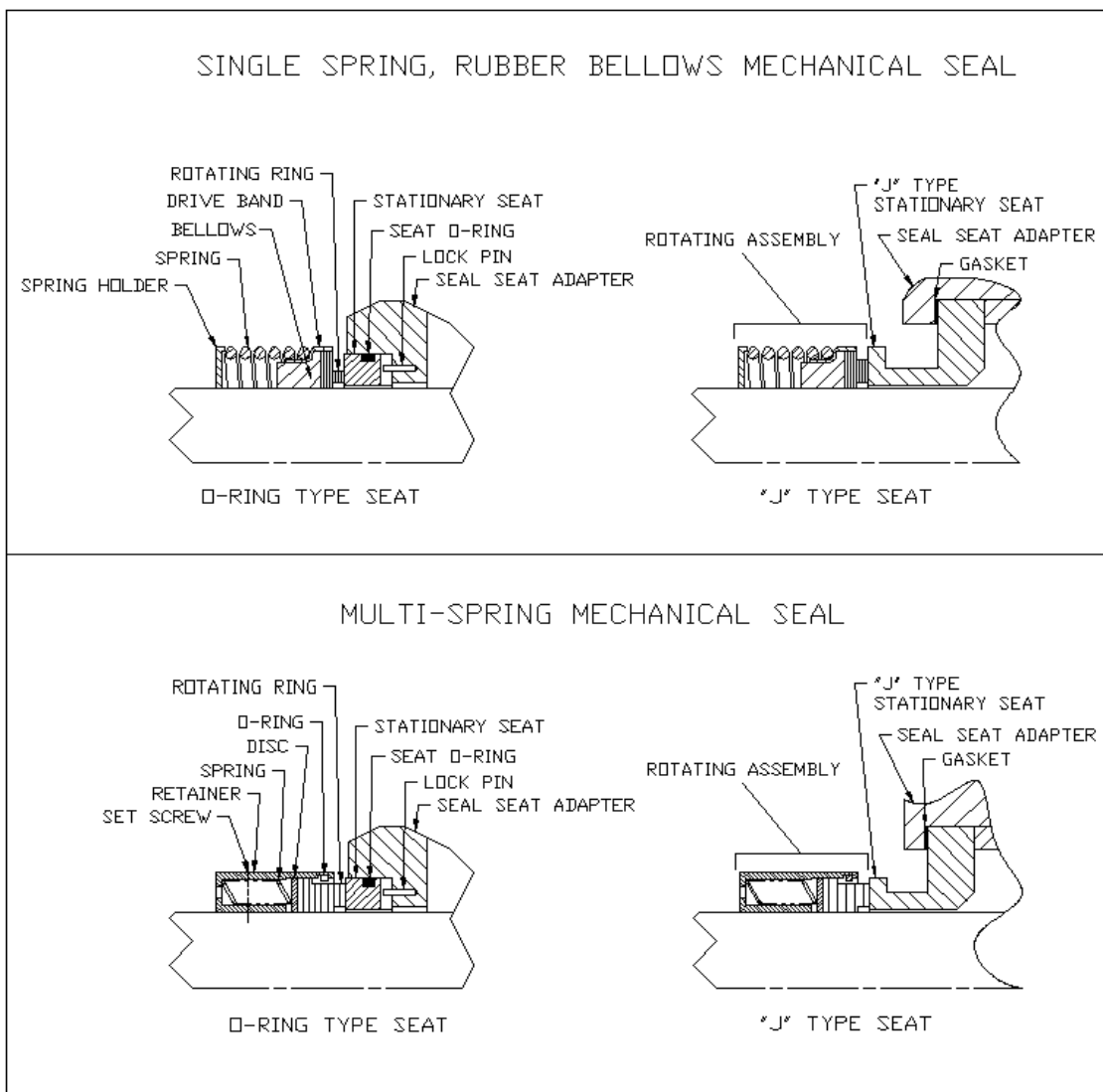

I. TROUBLESHOOTING

For assistance with troubleshooting see General Instruction Manual, SRM00046 or SRM00101 if pump is CE certified.

J. FIELD AND FACTORY SERVICE AND PARTS

Imo Pump maintains a staff of trained service personnel that can provide pump installation, pump start-up, maintenance/overhaul and troubleshooting supervision as well as installation and maintenance training.

Our factories provide maintenance as well as overhaul and test facilities the in event user prefers to return pumps for inspection or overhaul. Factory-overhauled pumps are normally tested and warranted "as-new" for a period of one year from date of shipment. For either field service or factory overhaul assistance, contact your local Imo Sales Office or representative at Technical/ Customer Service Department in Monroe, NC, USA.

Most pumps have repair kits available. Minor Repair Kits are used to repair leaking seals, bad bearings and/or for re-assembly after pump tear-down. They include (as applicable) pump shaft seals, packing, all gaskets/O-rings and bearings. Major Repair Kits are sufficient to rebuild completely worn-out pumps to "as-new" condition. They include all parts found in Minor Repair Kits plus all major internal parts subject to wear. Since kits have all necessary parts, kit purchase is preferred rather than selecting individual parts. When parts are individually selected from Parts List, some needed components are often overlooked. In addition, mixing worn or used parts with new parts risks rapid wear and shortened service life from new parts.

FIGURE 4 - AG,BG,EG,HG3D_(S) AND AG3DKH-350_ ASSEMBLY

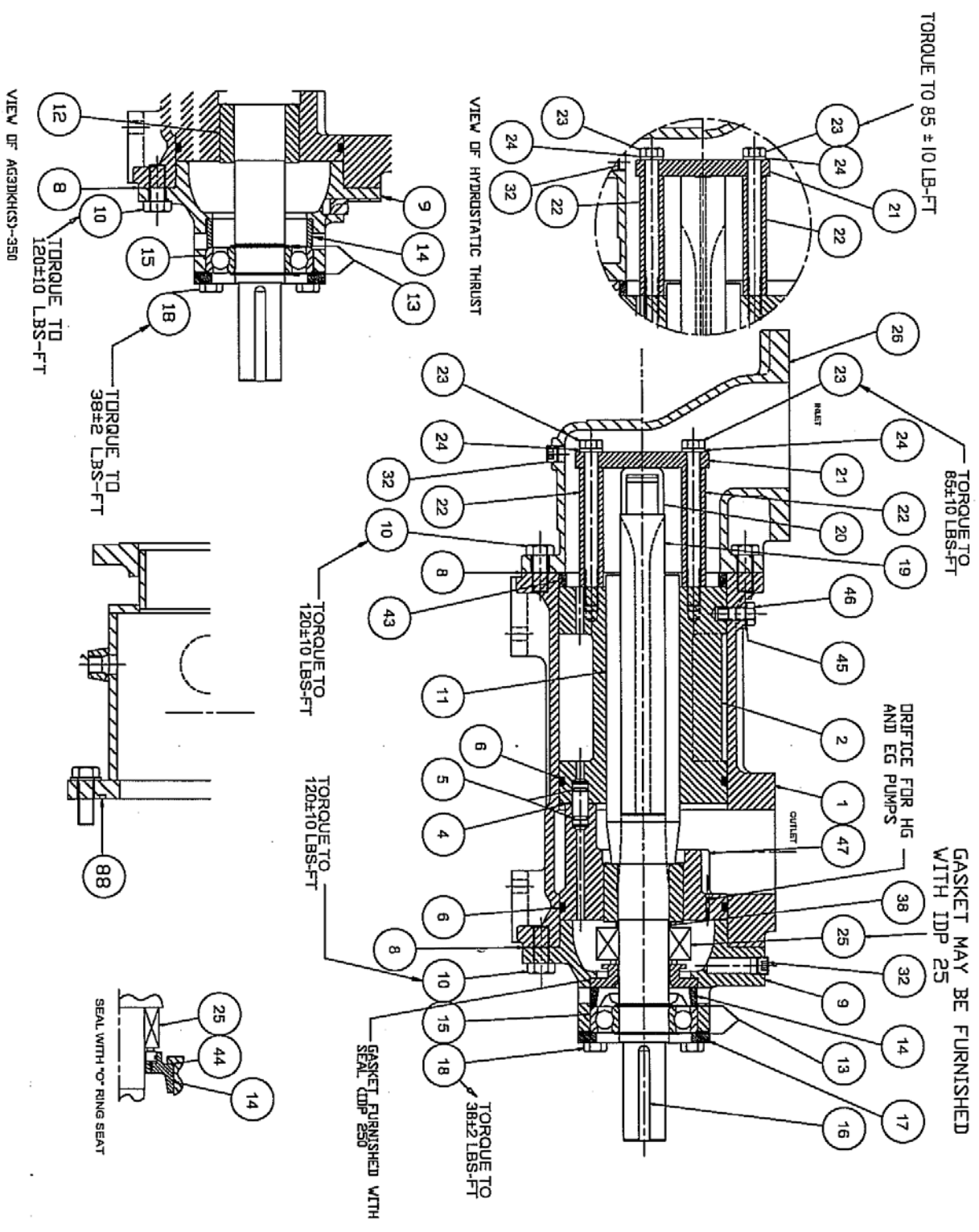
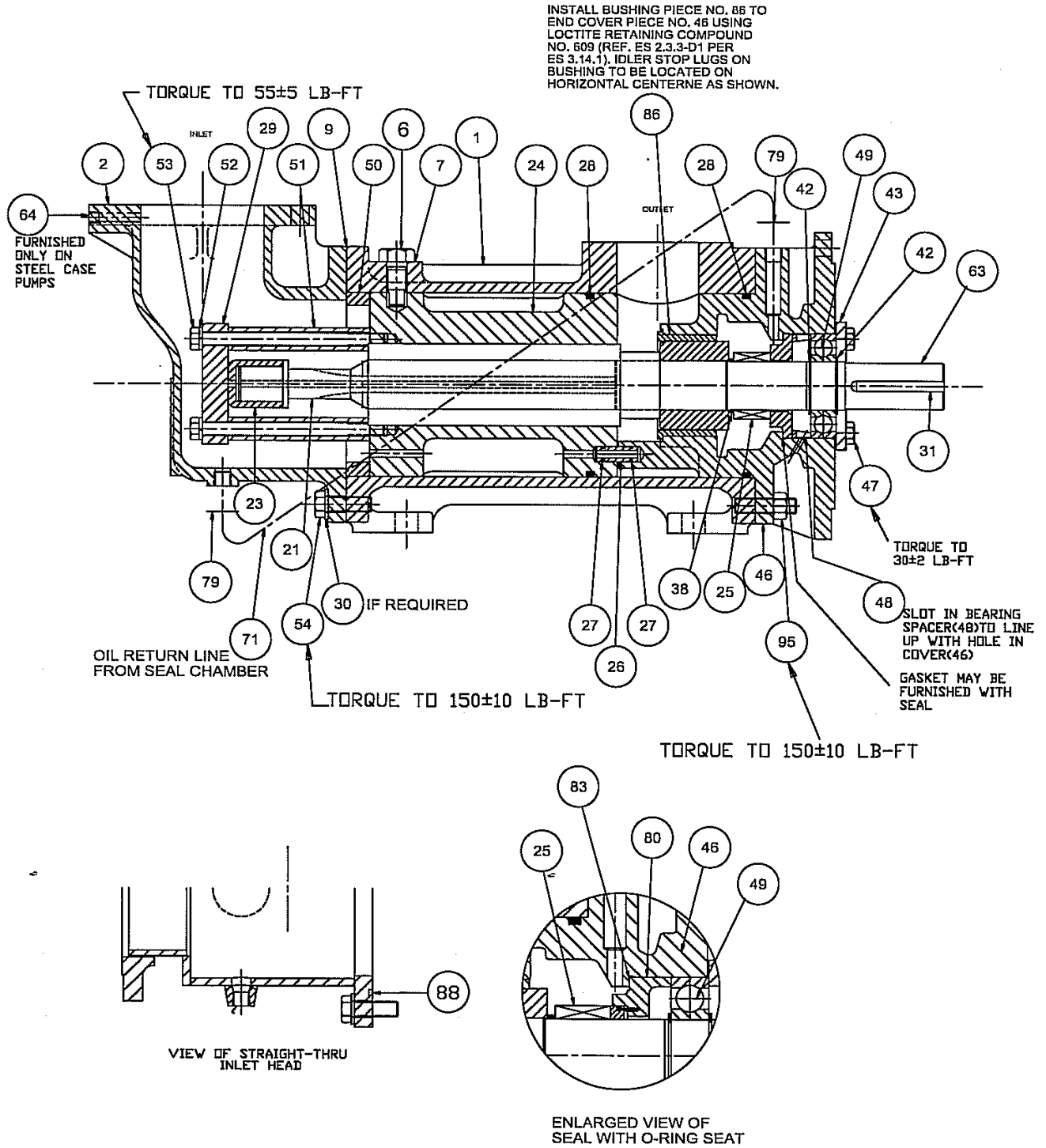
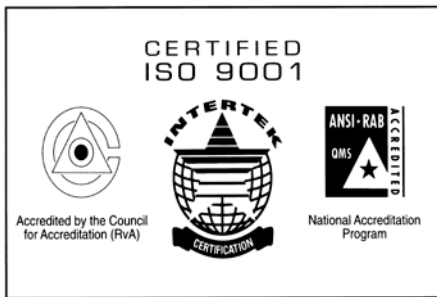

Figure 7: AG3D_C(S)-400 Assembly





COLFAX
Fluid Handling

Imo Pump

1710 Airport Road
PO Box 5020
Monroe, NC USA
28111.5020

Tel: +1.704.289.6511

Toll: +1.877.853.7867

Email: cc@colfaxcorp.com

Web: colfaxcorp.com

© 2012 Colfax Fluid Handling all rights reserved.

ALLWEILER® COT-PURITECHSM HOUTTUINTM IMO® LSCSM ROSSCOR® TUSHACO® WARREN®