







**Product Service Manual  
For  
DLH6DH(S)T-250, 312, 350, 400 PUMPS**

	<b>WARNING</b>	
<b>This manual and the “General Installation, Operation, Maintenance and Troubleshooting Manual” (SRM00046) should be read in their entirety prior to installing, operating or servicing this pump.</b>		

<b>Manual No. SRM00106</b>	<b>Rev. 01 (14-0290)</b>	<b>August, 2014</b>
----------------------------	--------------------------	---------------------

## READ ENTIRE PAGE BEFORE PROCEEDING

FOR SAFETY OF PERSONNEL AND TO PREVENT DAMAGE TO EQUIPMENT, THE FOLLOWING NOMENCLATURE HAS BEEN USED IN THIS MANUAL:

	<b>DANGER</b>	
Failure to observe precautions noted in this box can result in severe bodily injury or loss of life.		
	<b>WARNING</b>	
Failure to observe precautions noted in this box can cause injury to personnel by accidental contact with the equipment or liquids. Protection should be provided by the user to prevent accidental contact.		
<b>CAUTION</b>	<b>ATTENTION</b>	
Failure to observe the precautions noted in this box can cause damage or failure of the equipment.		
Non compliance of safety instructions identified by the following symbol could affect safety for persons:  	Safety instructions where electrical safety is involved are identified by:  	Safety instructions which shall be considered for reasons of safe operation of the pump and/or protection of the pump itself are marked by the sign:  <b>ATTENTION</b>

## CONTENTS

SAFETY AND TABLE OF CONTENTS .....	2
A. GENERAL INSTRUCTIONS .....	3
B. INTRODUCTION .....	3
C. DESCRIPTION OF PUMP FEATURES .....	3
D. PUMP MODEL IDENTIFICATION .....	4
E. ORDERING INSTRUCTIONS .....	4
F. OPERATION .....	4
G. PARTS LIST .....	5
H. PUMP MAINTENANCE (Assembly and Disassembly) .....	5
I. TROUBLESHOOTING .....	9
J. FIELD AND FACTORY SERVICE AND PARTS .....	9
K. ASSEMBLY DRAWINGS .....	10 thru 13

<b>ATTENTION</b>
<i>If operation of pump is critical to your business, we strongly recommend you keep a spare pump or major repair kit in stock at all times. As a minimum, a minor repair kit (o-rings, gaskets, shaft seal and bearings) should be kept in stock so pump refurbishment after internal inspection can be accomplished.</i>

## A. GENERAL INSTRUCTIONS

Instructions found herein cover disassembly, assembly and parts identification of Series DLH6D pumps.

**NOTE:** *Individual contracts may have specific provisions that vary from this manual. Should any questions arise which may not be answered by these instructions, refer to General Instructions Manual, SRM00046, provided with your order. For further detailed information and technical assistance please refer to Imo Pump, Technical/Customer Service Department, at (704) 289-6511.*

Manual cannot possibly cover every situation connected with installation, operation, inspection, and maintenance of equipment supplied. Every effort was made to prepare text of manual so that engineering and design data is transformed into most easily understood wording. Imo Pump must assume personnel assigned to operate and maintain supplied equipment and apply this instruction manual have sufficient technical knowledge and are experienced to apply sound safety and operational practices which may not be otherwise covered by this manual.

In applications where equipment furnished by Imo Pump is to become part of processing machinery, these instructions should be thoroughly reviewed to ensure proper fit of said equipment into overall plant operational procedures.



### WARNING

If installation, operation and maintenance instructions are not correctly and strictly followed and observed, injury to personnel or serious damage to pump could result. Imo Pump cannot accept responsibility for unsatisfactory performance or damage resulting from failure to comply with instructions.

## B. INTRODUCTION

This instruction manual covers Series DLH6D Imo pumps. This series of pumps has been designed for use in high pressure crude oil applications including those at low viscosities. Model, and design construction of each pump can be identified by designator code on pump nameplate. Definitions of model designators are identified in Figure 1.

## C. DESCRIPTION OF PUMP FEATURES

DLH6D Series pumps are positive displacement, rotary screw pumps consisting of a precision bored housing that encloses a driven screw (power rotor) and two intermeshing following screws (idler rotors). These screws, when rotating, form a succession of closures or cavities. As they rotate, fluid is moved axially from inlet port to outlet port in a continuous, uniform flow with minimum fluid pulsation and pump noise. Pumps contain a sealed, grease packed, ball bearing and carbide thrust and balance piston bushing for extended wear in contaminated fluids. .

## D. PUMP MODEL IDENTIFICATION

Instruction manual covers Imo Series DLH6D pumps. Model of each pump is identified on pump nameplate.

**Figure 1 – Model Designator Definitions**

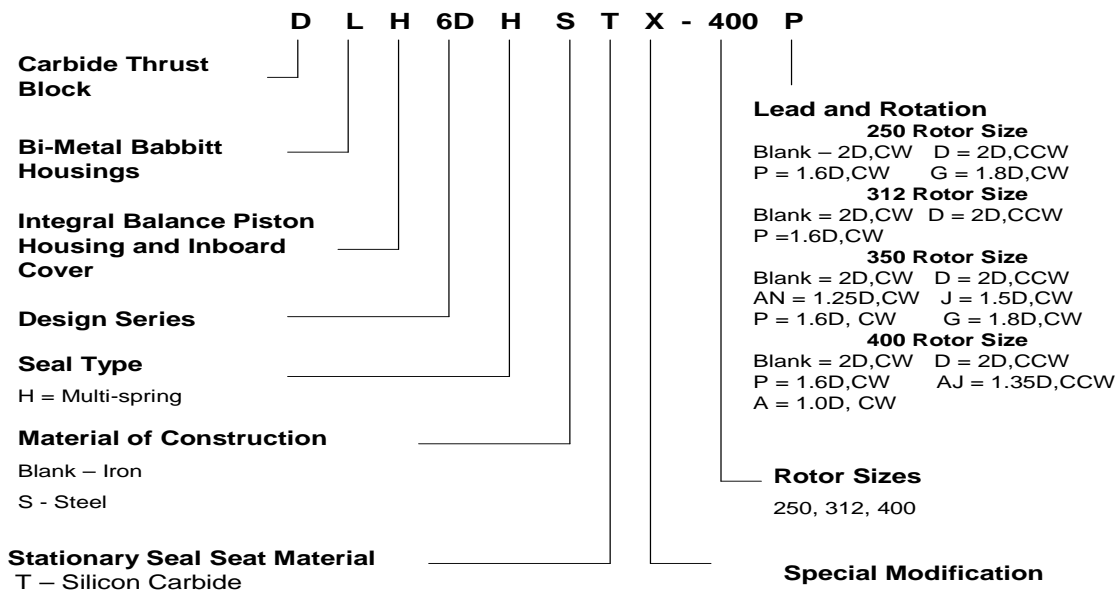

## E. ORDERING INSTRUCTIONS

When corresponding with Imo Pump regarding Series DLH6D pumps, refer to pump nameplate, this instruction manual, and assembly drawing as instructed below:

1. From pump nameplate, record the pump model number, serial number and manufactured date.
2. Record instruction manual number, revision and date.
3. From the assembly drawing and/or parts list (Table 2) in manual, provide IDP number(s) and names for replacement part(s).
4. Give above information to your Imo service representative. Please call 1-877-853-7867 for further guidance.

## F. OPERATION

### F.1 LIQUID LIMITATIONS

Never operate with thin liquids such as solvents or water. The pump is designed for liquids having general characteristics of oil.

### F.2 OPERATING LIMITS

#### CAUTION

#### ATTENTION

Operating conditions, such as speed, fluid viscosity, temperature inlet pressure, discharge pressure, filtration, duty cycle, drive type, mounting, etc., are interrelated. Due to these variable conditions, specific application limits may be different from that of operational limitations below. Equipment must not be operated without verifying system's operating requirements are within pump's capabilities.

Under no circumstances are the following operating limits to be exceeded without specific approval from Imo Pump.

**Table 1 – Normal Pump Operating and Structural Limits**

MAXIMUM SPEED .....	1800 Rpm
VISCOSITY .....	8 cSt (52 SSU) Minimum – 20,000 SSU (4,315 cSt) Maximum
MINIMUM – MAXIMUM LIQUID TEMPERATURE.....	0 to 250 F (-18 to 121 C)
MAXIMUM INLET PRESSURE.....	150 psig (10 Bar)
MAXIMUM DISCHARGE PRESSURE.....	.1500 psig (103 Bar), Cont. Duty
FILTRATION.....	(See General Instruction Manual, SRM00046)
DRIVE .....	Direct only
MOUNTING .....	Foot or Flange mounted in any attitude

**G. PARTS LIST**

**Table 2 – Pump Parts List**

IDP	QTY	DESCRIPTION	KIT	IDP	QTY	DESCRIPTION	KIT
1	1	Case		48	1	Seal Seat Adapter	
2	1	Inlet		49	1	Bearing	X
4	16	Inlet & Outlet Cap Screws (8 On 250 Size and 8 on 400 Size - 3225/369 Only)		50	1	Thrust Block	
6	1	Pin Stop		51	1	Thrust Plate	XX
7	1	Fastener Seal	X	52	2	Thrust Plate Capscrews	
8	2	Housing Snap Ring	XX	53	2	Thrust Block Capscrews	
9	1	O-ring (2 on 400 Size Except 3225/369)	X	54	2	Thrust Spacer	
15	8	Inlet Cap Screws (400 Size B/M 3225/369 Only)		55	1	Housing Spacer	
21	2	Idler	XX	57	1	Transducer Mounting Plate (250 Size Only)	
22	1	Idler Stop	XX	63	1	Power Rotor	XX
24	1	Housing	XX	67	2	Pipe Plugs	
25	1	Seal	X	68	2	Nipples (350 & 400 Size Only)	
26	1	Tube (312 Size Only)		69	1	Elbow (350 & 400 Size Only)	
28	1	O-Ring (1 on 400 Size)	X	70	1	Elbow (2 on 3220/367)	
31	1	Key		71	1	Seal Pipe	
38	1	Seal Spacer (Not on 400 Size)		74	1	Flareless Fitting (Not on 3220/367)	
42	2	Bearing Retaining Ring	X	79	1	Bal Piston Bushing	XX
43	1	Bearing Retainer		81	4	Idler Stop Capscrews (2 on 250 Size)	
46	1	Front Cover		83	1	Seal Seat Adapter O-Ring	X
47	4	Bearing Retainer Hex Bolts		91	16	Washers (312 Size Only)	

X = Minor Repair Kit Items.  
XX = Major Repair Kit Items. (Items marked (X) are included in Major Repair Kit).

## H. PUMP MAINTENANCE



### WARNING

Failure to observe precautions while installing, inspecting and maintaining pump can cause injury to personnel from accidental handling of liquids that may harm skin or clothing, or fire hazard risks from flammable liquids, or injury from high pressure fluid jets.



### DANGER

**BEFORE** working on equipment, make sure all power to equipment is disconnected and locked-out.

### H.1 GENERAL COMMENTS

Refer to assembly drawings for correct pump size for following instructions.

**NOTE:** Part number identifiers (IDP's) contained within parenthesis such as (9) refer to circled numbers shown on assembly drawings and Table 2.

### H.2 TOOLS REQUIRED

Procedures described in this manual require common mechanics hand tools, a torque wrench, dial indicator and suitable lifting device (such as) slings, straps, etc.

### H.3 DISASSEMBLY PROCEDURES

**SPECIAL NOTE: To service mechanical seal and ball bearings ONLY perform H.3, Steps 1 and 7thru 10 and H.4, Steps 6 thru 9 ONLY.**



### CAUTION

Fluid leakage from disassembly of pump may make floor slippery and cause personal injury.

1. Close suction and discharge piping to pump and disconnect piping. Remove seal piping (71). Remove drain plugs (67), and drain unit. Remove pump from driver, coupling and base plate. Remove coupling hub and key (31).
2. Remove bolts (4 or 15) and inlet head (2).
3. Remove O-ring (9) from inlet head (2).
4. Remove capscrews (53) to remove thrust plates (51 & 50) and spacers (54). Disassemble thrust plate (51) from block (50) by removing capscrews (52).
5. Remove spiral rings (8) from grooves in case (1). Remove housing spacer (55).
6. Remove idlers (21) by unscrewing them from inlet end of pump.



### CAUTION

Do not permit idlers (21) to drop as they emerge from housing (24).

7. Remove bolts (47) and bearing retainer (43).

8. Remove assembled power rotor (63). Removal of power rotor (63) includes removal of retaining rings (42), ball bearing (49), mechanical seal (25), seal seat adapter (48) and seal spacer (38) where applicable.
9. Disassemble power rotor (63) as follows:
  - a. Using a flat nosed tool, such as a screw driver, remove retaining rings (42) located on both sides of ball bearing (49) from their grooves in power rotor (63).
  - b. Sealed ball bearing (49) is assembled to power rotor (63) with a light press fit. Ball bearing (49) may be removed by using a bearing puller or a vertical arbor press. When using press, two pieces of key stock are to be placed through openings of seal seat adapter (48) underneath ball bearing (49) on both sides of power rotor shaft. Key stock should be long enough to support power rotor (63) as it is placed in press. Press ram is to be positioned against power rotor (63) coupling end face. Gently press power rotor (63) through ball bearing (49). Ensure power rotor (63) does not fall to floor once ball bearing (49) is off of its diameter.
  - c. Remove mechanical seal stationary seal seat adapter (48) from power rotor (63) shaft. Remove mechanical seal stationary sealing face from adapter (48). Loosen set screws on mechanical seal rotating assembly body and remove power rotor (63). Remove seal spacer (3) where applicable.
10. Remove O-ring (83) from inboard cover (46).
11. Remove bolts (4) and inboard cover (46) from case (1).
12. Remove O-ring (9) from inboard cover (46).
13. Remove idler stop subassembly (22) from inboard cover (46) by removing bolts (81).
14. Remove balance piston bushing (79) from inboard cover (46).
15. Remove stop pin (6) and fastener seal (7) from case (1).
16. Remove housing (24) from case (1). Remove o-ring (28) from housing (24).

**CAUTION**

Do not permit housing (24) to drop as it is removed from pump.

#### H.4 PUMP ASSEMBLY PROCEDURE

**Note:** Prior to reassembly of pump, all parts should be cleaned and inspected for nicks and burrs. Replace all worn or damaged parts. Imo Pump recommends replacement of all O-rings, gaskets, mechanical seal and ball bearing when these parts are disturbed from their previously installed positions. Coat all parts with light lubricating oil to assist in assembly.

1. Install O-ring (28) in groove of housing (24).
2. Install housing (24) in pump case (1), from suction end of case, aligning groove in housing (24) to stop pin hole in case (1). Install stop pin (6) with fastener seal (7) in case (1).
3. Install balance piston bushing (79) in bore of inboard cover (46).

4. Install idler stop (22) on inboard cover (46) with capscrews (81). Torque cap screws (81) to value on appropriate assembly drawing
5. Install O-ring (9 or 28) in inboard cover (46) and tube (26) in inboard cover (46), size 312 only. Install inboard cover (46) in case (1). Be sure with seal vent return hole (70) in inboard cover is facing up and tube (26) mates with hole in housing (24), size 312 only. . Secure with cap screws (4). Torque cap screws to value on appropriate assembly drawing.
6. Assemble mechanical seal (25), See figure 2 below, and ball bearing (49) as follows.
  - a. Install O-ring in groove of mechanical seal (25) stationary seat. Install mechanical stationary seat in mechanical seal seat adapter (48) ensuring that spring pin is properly positioned to engage slot in seal seat.
  - b. Install seal spacer (38), where applicable and then mechanical seal (25) rotating assembly on power rotor (63).
  - c. Wipe mechanical seal rotating and stationary faces with a clean, lint free cloth before assembling faces together.
  - d. Install assembled seal seat adapter (48) on power rotor shaft and carefully place the mechanical seal stationary face on the mechanical seal rotating face.
  - e. Install inner retaining ring (42) in groove of power rotor (63).
  - f. Press ball bearing (49) on power rotor (63), pressing only on inner race of ball bearing (49) until it is located against inner retaining ring (42).
  - g. Install outer retaining ring (42) in groove of power rotor (63).
  - h. Tighten mechanical seal rotating assembly (see figure 2) setscrews.
7. Install O-ring (83) to inboard cover (46) counter bore. A small amount of grease may be applied to hold the O-ring (83) in place.
8. Install assembled power rotor (63) in pump, centering all parts as they enter inboard cover (46). Align one of openings in seat seal adapter (48) over drain in inboard cover (46).
9. Install bearing retainer (43) to inboard cover (46) using bolts (47). Torque cap screws (47) to value on appropriate assembly drawing.
10. Install idlers (21) into rotor housing by meshing threads with power rotor thread and screwing them into housing idler bores.
11. Install spacer (55) in pump case (1) bore and position next to housing (24).
12. Install spiral rings (8) to groove in pump case (1) bore.
13. Assemble thrust plate and block (50 & 51) with capscrews (52). Torque cap screws (52) to value on appropriate assembly drawing. Install spacers (54) and thrust plate assembly, to housing (24) using cap screws (53). Torque cap screws (53) to value on appropriate assembly drawing
14. Install O-ring (9) to groove in inlet head (2).
15. Install inlet head (2) using bolts (4 or 15). Torque bolts to value on appropriate assembly drawing.



16. Install seal piping (71), including fittings, if they were removed, and drain plugs (67).

**Note:** Inlet head (37) can be rotated and repositioned in 90° increments to suit suction piping. To change inlet position, disconnect seal piping (42), remove bolts (55) and rotate inlet head to desired position. Install bolts (55) and torque to value on assembly drawing. Reconnect seal piping (42).

17. Install coupling hub key (31). Install and align pump and driver as specified in General Instruction Manual, SRM00046.

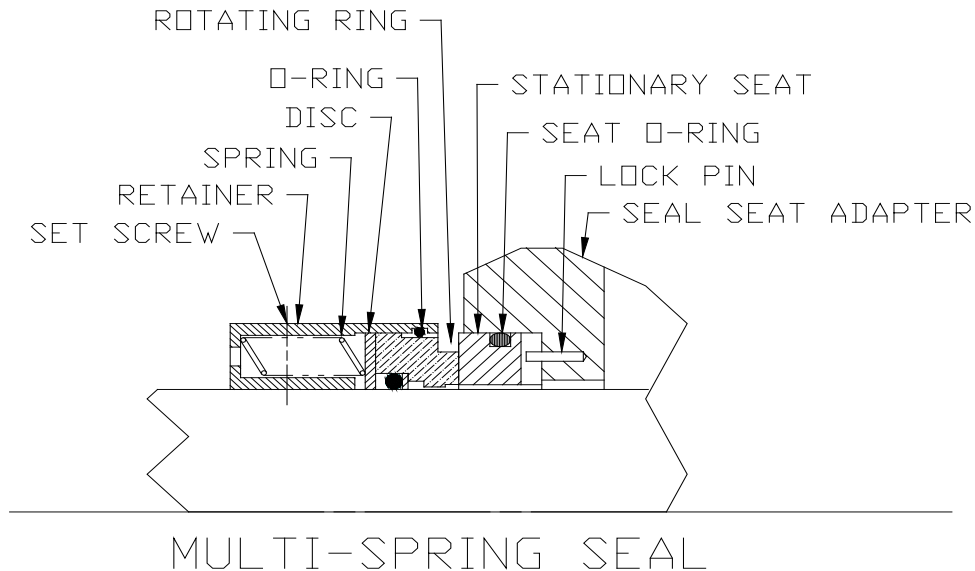

**Figure 2**

## I. TROUBLESHOOTING

For assistance with troubleshooting see General Instruction Manual, SRM00046.

## J. FIELD AND FACTORY SERVICE AND PARTS

Imo Pump maintains a staff of trained service personnel that can provide pump installation, pump start-up, maintenance/overhaul and troubleshooting supervision as well as installation and maintenance training.

Our factories provide maintenance as well as overhaul and test facilities in event user prefers to return pumps for inspection or overhaul. Factory-overhauled pumps are normally tested and warranted “as-new” for a period of one year from date of shipment. For either field service or factory overhaul assistance, contact your local Imo Sales Office or representative at Technical/Customer Service Department in Monroe, NC, USA, 1-877-853-7867.

Most pumps have repair kits available. Minor Repair Kits are used to repair leaking seals, bad bearings and/or for re-assembly after pump tear-down. They include (as applicable) pump shaft seals, packing, all gaskets/O-rings and bearings. Major Repair Kits are sufficient to rebuild completely worn-out pumps to “as-new” condition. They include all parts found in Minor Repair Kits plus all major internal parts subject to wear. Since kits have all necessary parts, kit purchase is preferred rather than selecting individual parts. When parts are individually selected from Parts List, some needed components are often overlooked. In addition, mixing worn or used parts with new parts risks rapid wear and shortened service life from new parts.

# DLH6DHT-250 ASSEMBLY

303 LB

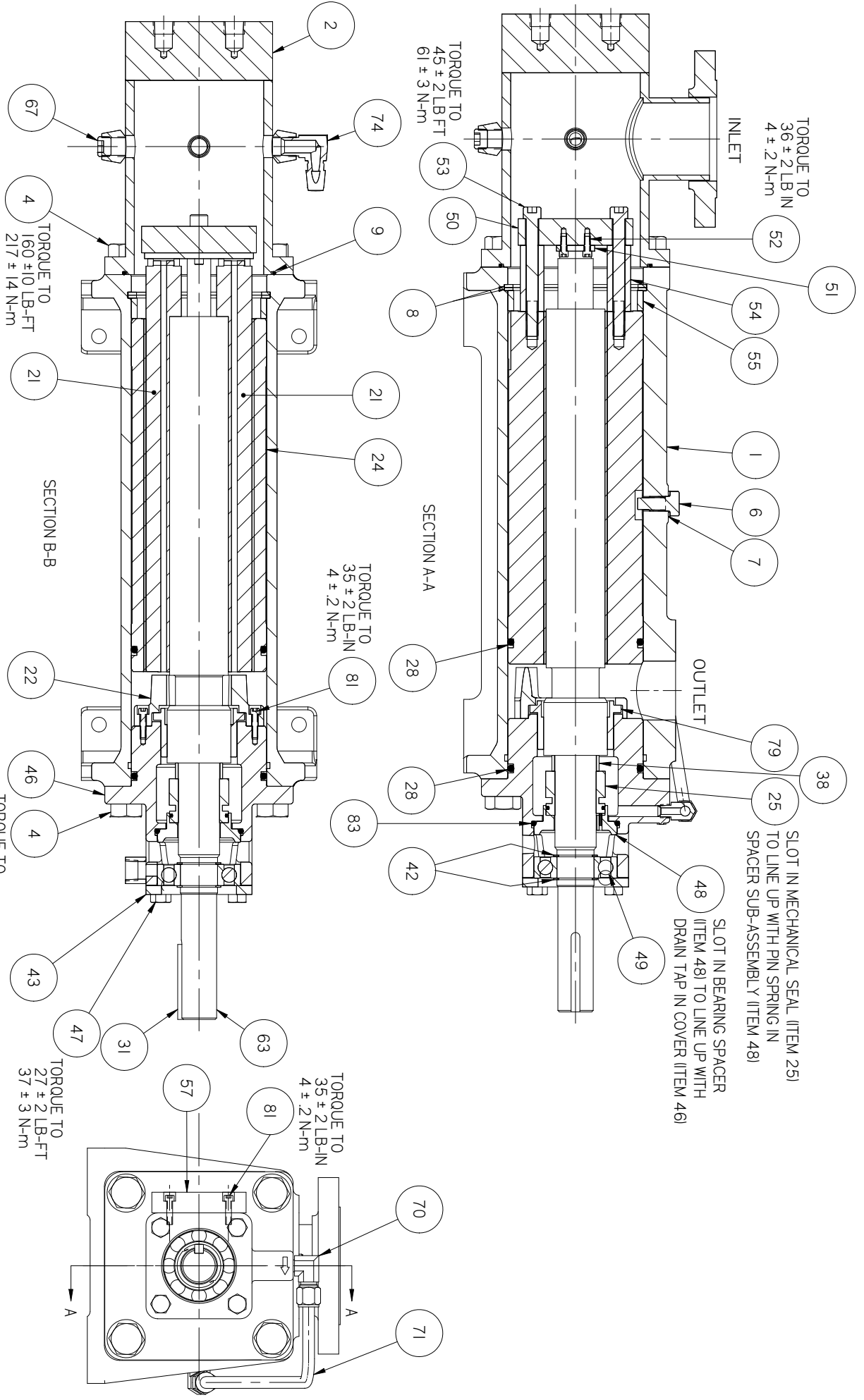

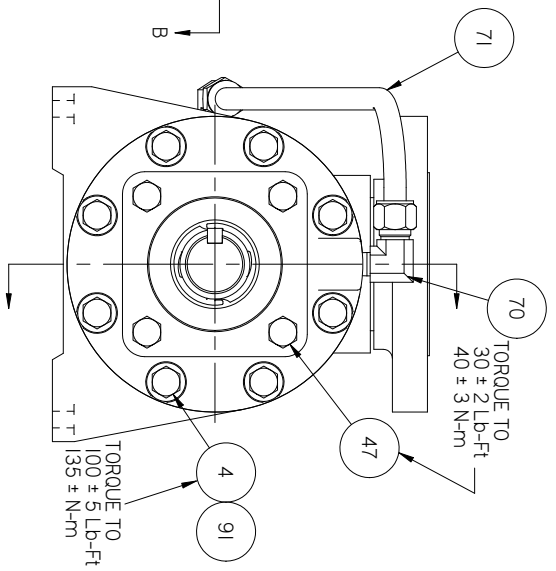
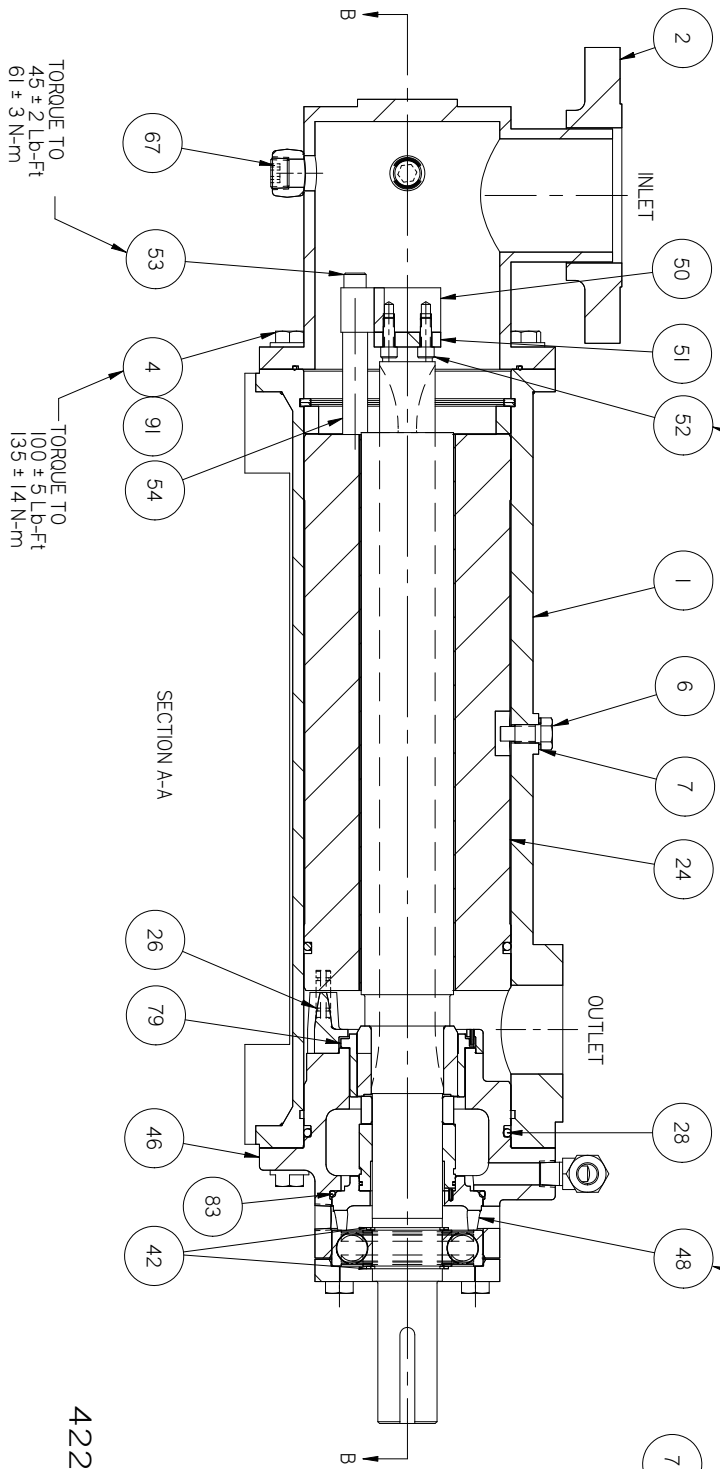
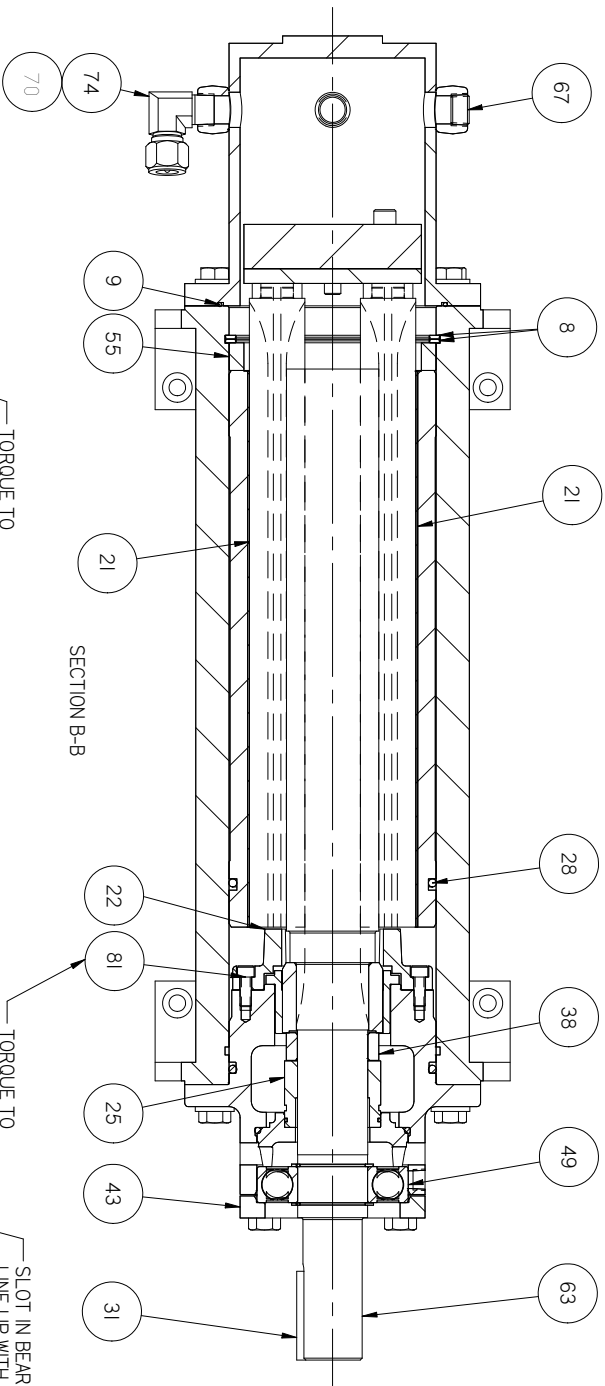

4222 LBS

# DLH6DHT-312 ASSEMBLY

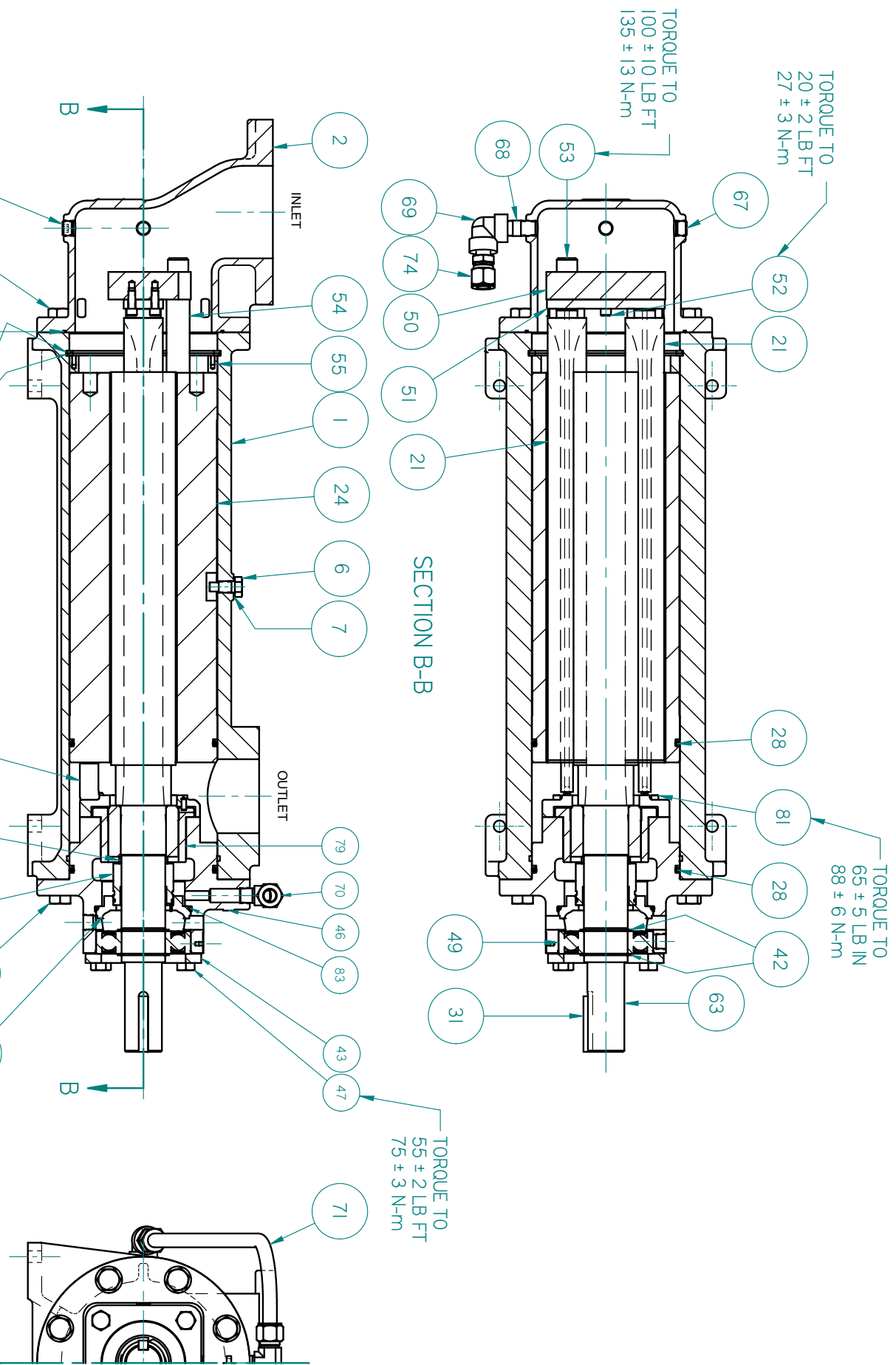

656 Lb.

# DLH6DHT-350 ASSEMBLY

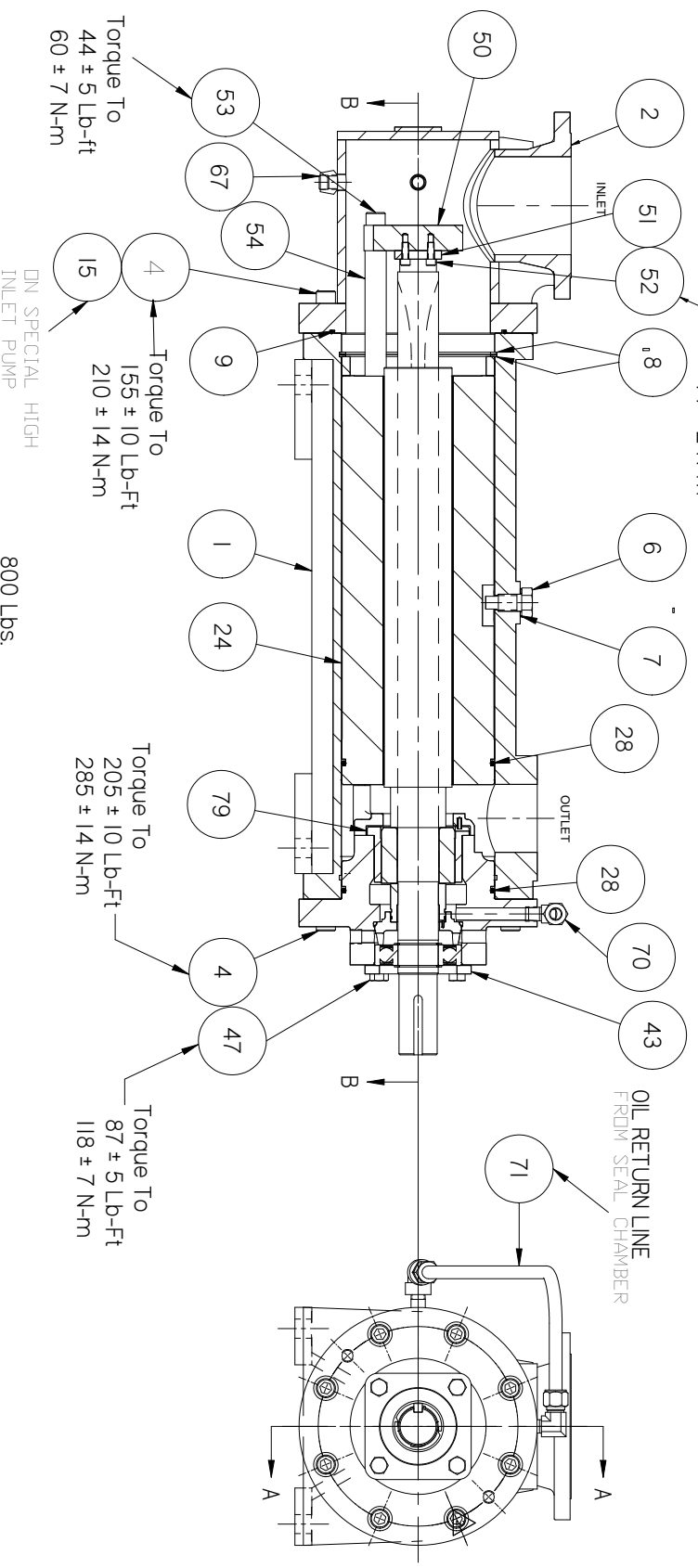
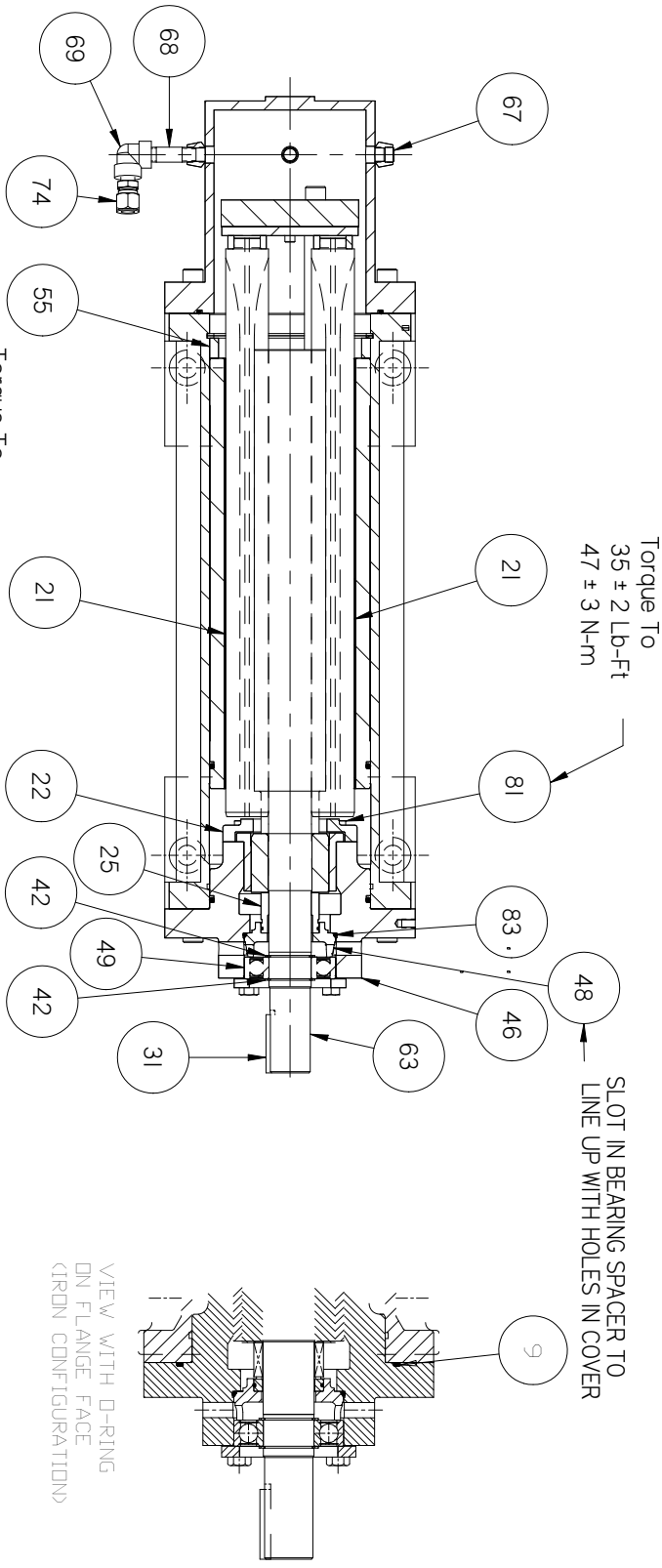

# ASSEMBLY DLH6DH(S)T-400

# COLFAX

Fluid Handling

**IMO Pump**  
1710 Airport Road 28110  
PO Box 5020  
Monroe, NC/USA 28111-5020

Tel: 1+ (704) 289-6511  
Email: [imo.pump@colfaxcorp.com](mailto:imo.pump@colfaxcorp.com)  
Web: [www.imo-pump.com](http://www.imo-pump.com)

