



## 8L-912\_ PUMP MODELS

# GENERAL START-UP CHECKS & TROUBLESHOOTING and VERIFICATION RECORD\*



### WARNING

The Imo General Installation Operation, Maintenance, and Troubleshooting Manual, (No. SRM00046), along with this manual, and the pump-specific Product Service Manual, as well as all other component manuals supplied with these type units should be read thoroughly prior to pump installation, start-up, operation, maintenance or troubleshooting.

*\* This document contains multiple provisions for signature verification of critical pump and system checks prior to and during pump start-up*

**Manual No. SRM00118**

**Rev. 00**

**June 2013**

### **Imo Pump**

1710 Airport Road  
PO Box 5020  
Monroe, NC USA  
28111.5020

*Tel:* +1.704.289.6511

*Email:* [cc@colfaxcorp.com](mailto:cc@colfaxcorp.com)

*Web:* [colfaxcorp.com](http://colfaxcorp.com)

## IMPORTANT NOTE

The importance of seal chamber priming cannot be overemphasized. Due to the prevalence of seal damage and leakage caused by not filling the seal chamber with liquid before putting a pump in service, this page is located at the beginning of this document.

### SEAL CHAMBER PRIMING

Fill mechanical seal chamber with liquid to insure seal does not start dry. This can be done by removing seal vent set-screw and pouring liquid into vent passageway before opening pump inlet. Alternately, seal chamber can be vented in situations where inlet pressure is above atmospheric by opening inlet and discharge valves and then loosening seal vent plug to allow positive inlet pressure to push air out of seal chamber until oil flows from it. **See figure below.**

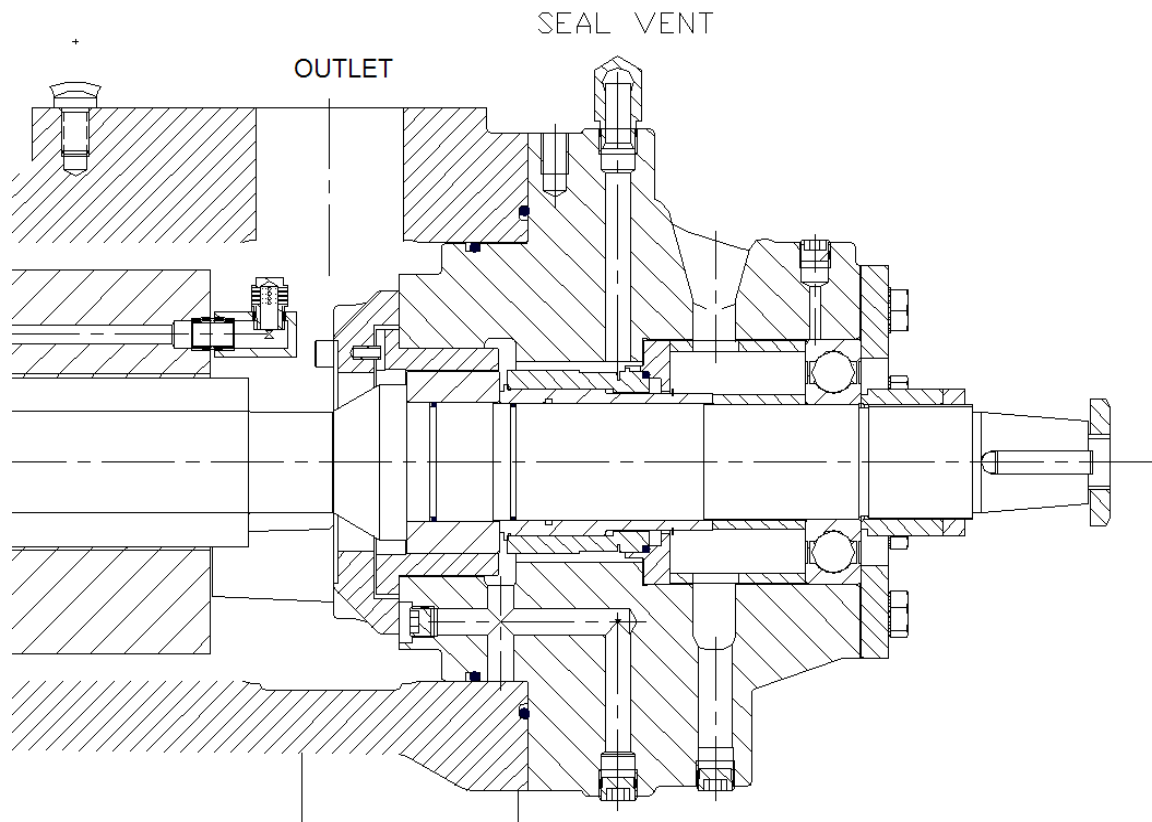

### Filling or Venting Seal Cavity Using Seal Vent

#### CAUTION

Failure to fill or vent seal chamber as described above may cause damage to seal running faces which may result in seal leakage.



## READ THIS ENTIRE PAGE BEFORE PROCEEDING

FOR SAFETY OF PERSONNEL AND TO PREVENT DAMAGE TO EQUIPMENT, FOLLOWING NOMENCLATURE HAS BEEN USED IN THIS MANUAL:

	<b>DANGER</b>	Failure to observe precautions noted in this box can result in severe bodily injury or loss of life.
-----------------------------------------------------------------------------------	---------------	------------------------------------------------------------------------------------------------------

	<b>WARNING</b>	Failure to observe precautions noted in this box can cause injury to personnel by accidental contact with equipment or liquids. Protection should be provided by the user to prevent accidental contact.
-----------------------------------------------------------------------------------	----------------	----------------------------------------------------------------------------------------------------------------------------------------------------------------------------------------------------------

<b>CAUTION</b>	<b>ATTENTION</b>	Failure to observe the precautions noted in this box can cause damage or failure of the equipment.
----------------	------------------	----------------------------------------------------------------------------------------------------

Non compliance of safety instructions identified by following symbol could affect safety for persons:  <div style="text-align: center;"></div>	Safety instructions where electrical safety is involved are identified by:  <div style="text-align: center;"></div>	Safety instructions which shall be considered for reasons of safe operation of pump and/or protection of pump itself are marked by sign:  <div style="text-align: center;"><b>ATTENTION</b></div>
-----------------------------------------------------------------------------------------------------------------------------------------------------------------------------------------------------------------------------------------	--------------------------------------------------------------------------------------------------------------------------------------------------------------------------------------------------------------	---------------------------------------------------------------------------------------------------------------------------------------------------------------------------------------------------------

<b>ATTENTION</b>	If operation of this pump is critical to your business, we strongly recommend you keep a spare pump or major repair kit in stock at all times. As a minimum, a minor repair kit (o-rings, gaskets, shaft seal and bearings) should be kept in stock so pump refurbishment after internal inspection can be accomplished.
------------------	--------------------------------------------------------------------------------------------------------------------------------------------------------------------------------------------------------------------------------------------------------------------------------------------------------------------------

### CONTENTS

FILLING AND VENTING SEAL CAVITIES.....	1
SAFETY AND TABLE OF CONTENTS.....	2
A - GENERAL.....	3
B – DESCRIPTION OF PUMP.....	4
C – INSTALLATION / ASSEMBLY.....	4
D – START-UP.....	8
E - TROUBLESHOOTING.....	11 - 12

# APPLICATIONS MANUAL FOR IMO PUMPS

## A GENERAL

Instructions found herein cover general start-up of subject equipment. NOTE: Individual contracts may have specific provisions that vary from this manual. Should any questions arise which may not be answered by these instructions, refer to specific pump instruction manual provided with your order. For further detailed information and technical assistance to questions not answered by these manuals, please refer to Imo Pump, Technical/Customer Service Department, at (704) 289-6511.

This manual cannot possibly cover every situation connected with the start-up of subject pump types. Every effort was made to prepare text of manual so that engineering and design data was transformed into easily understood wording. Imo Pump must assume personnel assigned to operate and maintain supplied equipment and apply instruction manual have sufficient technical knowledge and experience to use sound safety and operational practices which may not be otherwise covered by this manual.

In applications where equipment furnished by Imo Pump is to become part of a process or other machinery, these instructions should be thoroughly reviewed to determine proper fit of equipment into overall plant operational procedures.



### WARNING

If start-up instructions are not correctly and strictly followed and observed, injury to personnel or serious damage to pump could result. Imo Pump cannot accept responsibility for unsatisfactory performance or damage resulting from failure to comply with instructions.

## B DESCRIPTION OF THE PUMP

See specific pump instruction manual provided with your order.

## C INSTALLATION / ASSEMBLY



### WARNING



On critical or dangerous equipment, provide safety and emergency systems to protect personnel and property from injury due to pump malfunction. If pumped liquids are flammable, toxic, corrosive, explosive or otherwise hazardous, provide for safety in the event of leakage or malfunction. BEFORE working on equipment, make sure all power to equipment is disconnected and locked-out.

### C.1 TOOLS

Procedures described in this manual require common mechanics hand tools, dial indicators for alignment and suitable lifting devices such as slings, straps, spreader bars, etc.

### C.2 FOUNDATIONS AND BASEPLATES

Foundations and baseplates must be designed and installed so pump and driver alignment can be maintained at all times. Be sure baseplates are level and rest on smooth flat surfaces.

Signature \_\_\_\_\_ Date \_\_\_\_\_

**C.3 GENERAL PUMP AND DRIVER ALIGNMENT**

**C.3.1 CHECK THAT COUPLING HALVES ARE INSTALL PROPERLY**

Refer to coupling manufacture’s documentation supplied with unit.

Signature \_\_\_\_\_ Date \_\_\_\_\_

**C.3.2 PERFORM ALIGNMENT OF PUMP AND DRIVE SHAFTS**

Use dial indicators. Acceptable alignment has been attained when FIM (Full Indicator Movement) is less than or equal to 0.005 inch (0.13 mm) for face (angularity) and rim (parallelism) readings at or near coupling outer diameter while rotating both shafts together one full turn (360°). Record and document final alignment number.

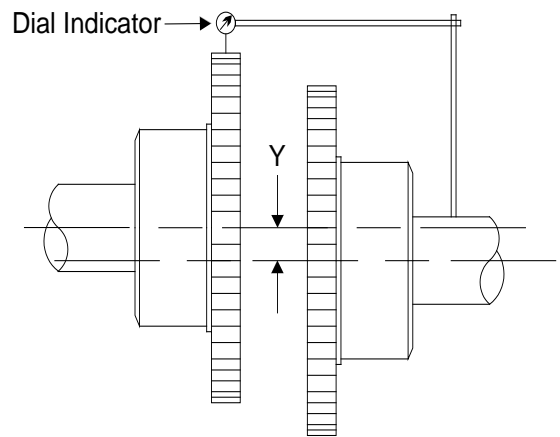
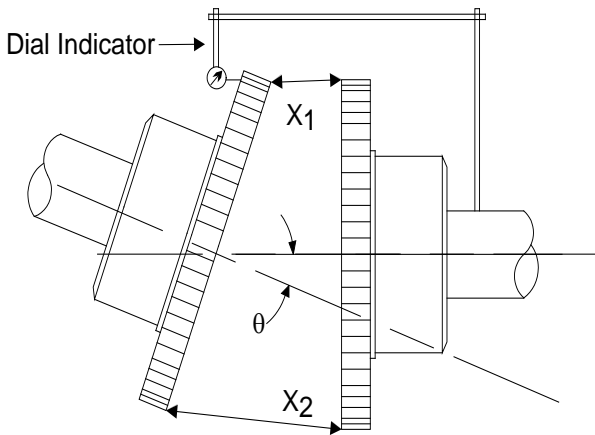

**A. Face Check (Angularity)**

Rotating both shafts together for one full turn align pump and driver until shaft centerlines are parallel ( $\theta = 0$ ,  $X_1 = X_2$ ) within 0.005 inch (0.13 mm) FIM.

**B. Face Check (Parallelism)**

Rotating both shafts together for one full turn, align pump and driver until shaft centerlines coincide ( $Y = 0$ ) within 0.005 inch (0.13 mm) FIM.

**Final Alignment:** Face \_\_\_\_\_ Rim \_\_\_\_\_

Signature \_\_\_\_\_ Date \_\_\_\_\_

<b>CAUTION</b>	<b>ATTENTION</b>
Pipe strain will distort a pump. This could lead to pump and piping malfunction or failure	

**C.3.3.1 PIPING STRAIN EFFECT ON ALIGNMENT – INITIAL CHECK**

Verify that all piping connected to the pump is independently supported and not allowed to impose strains on pump casing including allowing for expansion and contraction due to pressure and temperature changes.

Signature \_\_\_\_\_ Date \_\_\_\_\_

### C.3.3.2 PIPING STRAIN EFFECT ON ALIGNMENT – FINAL CHECK

Check all pump and driver mounting bolts and fasteners for proper tightness/torque. Verify no pipe strain exists by loosening and removing all fasteners from the suction and discharge piping. Check that both suction and discharge flange faces align bolt hole to bolt hole and bolts can be easily inserted in the flanges. Distances between flange faces should be checked to ensure excessive forces is not required to seal gaskets/O-rings thus preventing leakage. Refer to the applicable Imo Outline Standard Drawing for Maximum Pump Forces (F) and Moments (M). Reinstall all fasteners and torque to proper torque requirement. Recheck and verify alignment remains within the above standard.

Signature \_\_\_\_\_ Date \_\_\_\_\_

### C.4 RELIEF VALVE

Check relief valve location and setting. Relief valve should be connected to pump discharge lines as close to pump as possible and with no other valving or components between pump and relief valve. Ensure relief valve setting does not exceed maximum pressure rating of pump, including pressure accumulation at 100% bypass.

Signature \_\_\_\_\_ Date \_\_\_\_\_

### C.5 SUCTION STRAINER / FILTER

When pumping heavy crude oil, check to ensure that suction strainer meets the 5 to 6 mesh strainer screen size or those with about 1/8 inch (3 mm) openings.

Signature \_\_\_\_\_ Date \_\_\_\_\_

### C.6 GAGES

Check to ensure adequate pressure and temperature gages are installed for monitoring pump's operating conditions. These gages should be easily readable and placed as close as possible to pump's inlet and outlet ports.

Signature \_\_\_\_\_ Date \_\_\_\_\_

### C.7 START-UP, OPERATION AND SHUTDOWN

<b>CAUTION</b>	<b>ATTENTION</b>
<p>Operating factors such as speed, liquid viscosity, temperature, inlet pressure, discharge pressure, filtration, duty cycle, drive type, mounting, etc., are interrelated. Due to these variable conditions, specific application limits may be different from pump's operating and structural limits. Equipment must not be operated without verifying system's operating requirements are within pump's capabilities.</p>	

	<b>DANGER</b>
<p>Make sure all power equipment is disconnected and locked-out before proceeding.</p>	

## C.8 ELECTRICAL CONNECTIONS

### C.8.1 VERIFY ELECTRICAL REQUIREMENTS

Ensure electrical requirements of driver match those of electrical supply with respect to voltage, number of phases and terminal connections.

Signature \_\_\_\_\_ Date \_\_\_\_\_

### C.8.2 VERIFY ROTATION DIRECTION

Check that driver has been wired to rotate in correct direction. Before doing so, ensure pump coupling is disconnected.

Signature \_\_\_\_\_ Date \_\_\_\_\_

## C.9 ROTATION

Before connecting couplings, check pump rotation to be sure it matches rotation of driver. When coupling is connected and shafts are correctly aligned, pump should turn freely by hand. Rotation direction is indicated by an arrow cast on casing or by an attached plate showing a rotation direction arrow. See Figure 11.

Signature \_\_\_\_\_ Date \_\_\_\_\_

<b>CAUTION</b>	<b>ATTENTION</b>
<p>Operating pump in reverse direction may cause pump damage. Make sure rotation direction is not confused with inlet or outlet flow direction arrows. Please see Figure 11 below.</p>	

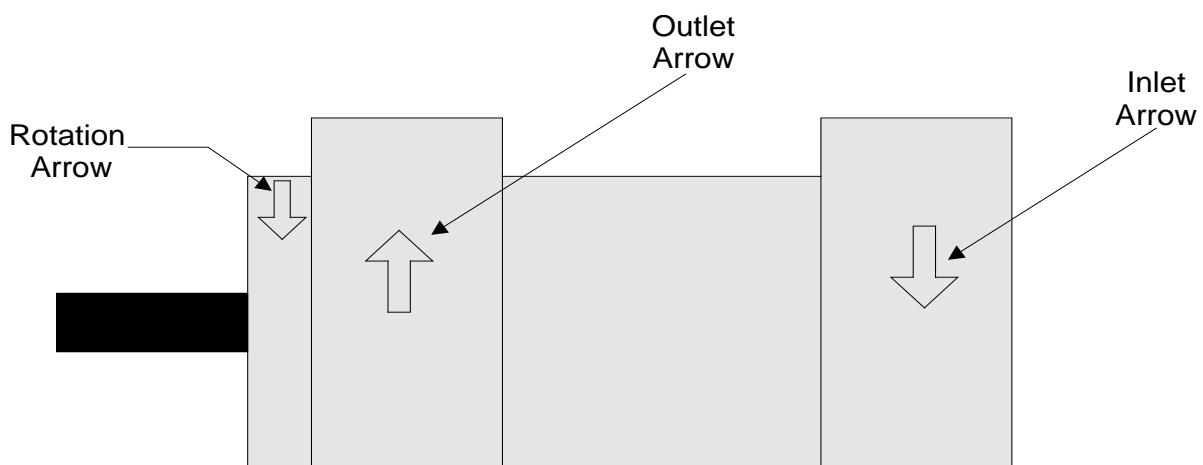

**FIGURE 11**

## C.10 COVERS AND GUARDS

Before starting pump, insure all protective-covers and guards are in place.

Signature \_\_\_\_\_ Date \_\_\_\_\_

	<b>WARNING</b>	<b>DANGER</b>
<p>To protect personnel from accidental contact with rotating couplings, sheaves, belts, shaft, keys, keyways, etc., install following covers or guards over:</p> <ul style="list-style-type: none"><li>• Bracket openings on flange mounted pumps.</li><li>• Couplings and shafts on foot mounted pumps.</li><li>• Sheaves, gears, chains, belts or other type drives.</li></ul>		

## C.11 VALVES, GAGES & SENSORS

Cycle all applicable piping valves from fully shut to fully open to ensure valves operate correctly. This includes manual and remotely operated valves.

Signature \_\_\_\_\_ Date \_\_\_\_\_

### C.11.1

Check all valve position indicators to ensure they are functioning properly. Verify control room valve position indicators match actual valve position at local and remote stations.

Signature \_\_\_\_\_ Date \_\_\_\_\_

### C.11.2

Check relief valves settings to ensure relieving pressure settings are correct.

Signature \_\_\_\_\_ Date \_\_\_\_\_

### C.11.3

Check remote pressure and temperature sensors to ensure they are calibrated and signal readings are correct.

Signature \_\_\_\_\_ Date \_\_\_\_\_

### C.11.4

If installed, check air regulators on remote operated valves to ensure they are properly adjusted and set.

Signature \_\_\_\_\_ Date \_\_\_\_\_



**C.11.5**

If installed, check all communications and signals to central control room to ensure they are operating properly.

Signature \_\_\_\_\_ Date \_\_\_\_\_

**C.11.6**

If installed, check communications and signals to VFD to ensure they are operating properly.

Signature \_\_\_\_\_ Date \_\_\_\_\_



**WARNING**

Starting a pump with discharge line blocked and without adequate relief protection will cause catastrophic pump failure and possible injury to personnel.

**C.12 INTERMEDIATE DRIVE LUBRICATION**

Some Imo pump units include intermediate gearboxes or other devices between pump and driver. When these devices are present, lubrication is required. Add lubricant to specified level per device manufacturer’s recommendations before start-up.

Signature \_\_\_\_\_ Date \_\_\_\_\_

**C.13 PUMP AND SEAL CHAMBER PRIMING**

**C.13.1 Pump Priming**

Ensure the pump is properly filled and primed prior to starting the pump.

Signature \_\_\_\_\_ Date \_\_\_\_\_

**C.13.2 Seal Chamber Priming** – See Page 2 of this document.

**D. START-UP**



**WARNING**

The minimum allowable differential pressure for a 8L-912 pumps (regardless of rotor lead) is 300 PSI when pumping liquids having viscosities less than or equal to 450 cSt and shaft speeds of less than or equal to 1200 rpm. Liquids with viscosities exceeding 450 cSt, and/or with shaft speeds higher than 1200 rpm, will require a differential pressure greater than 300 psi. The magnitude of the pressure will depend on both the viscosity and the shaft speed. Contact Imo Pump for additional information.

## D.1 Variable Frequency Drives (VFD)

### D.1.1

When utilizing VFD's with positive displacement pumps, verify minimum and maximum speed ranges intended for the pumping application. Maximum speed must consider the inlet pressure available for the fluid viscosity range. The minimum operating speed is dependent on the minimum operating viscosity and associated discharge pressure.

**Minimum Speed Allowed** \_\_\_\_\_ **Maximum Speed Allowed** \_\_\_\_\_

**Signature** \_\_\_\_\_ **Date** \_\_\_\_\_

### D.1.2

When starting positive displacement pumps with VFD's, there will be a delay from the initial start until the motor reaches the selected minimum operating speed. In some applications, such as crude oil pipeline transfer, the pump needs to be operated in full fluid bypass mode through a control valve loop during the VFD speed ramp-up time. Once the minimum operating speed is attained, the control valve should completely close and the system operated as intended. The time delay should be relatively short, approximately 30 seconds to two minutes. For system shut down, it is recommended this procedure be followed in reverse order. Verify the control valve setting meet the above requirements.

**Signature** \_\_\_\_\_ **Date** \_\_\_\_\_

## D.2 MINIMUM PUMP DIFFERENTIAL PRESSURE WARNING

To avoid pump damage, warning above must be heeded. Verify that system components have their proper settings set and been adjusted to achieve above requirement at initial start-up of pump. Boost pressure portion of system MUST be started and in full operation prior to starting main pump. Above requirement is initially achieved via system by-pass loop piping and valving components, this includes relief valves as well as automatic operating control valves and include start-up by pass valve.

**Signature** \_\_\_\_\_ **Date** \_\_\_\_\_

## D.3 VERIFY PROPER ROTATION

Start and immediately stop (jog) the driver three or four times in order to verify proper pump rotation and to insure pump is filled with liquid.

**Signature** \_\_\_\_\_ **Date** \_\_\_\_\_

## D.4 NOISE AND/OR VIBRATION

When pump is running, check for unusual noise and/or vibration. Investigate any abnormalities before proceeding.

**Signature** \_\_\_\_\_ **Date** \_\_\_\_\_

**D.5 CHECK PRESSURE GAGE READINGS**

Check inlet and outlet gages to see if pump is operating within its ratings.

**Signature** \_\_\_\_\_ **Date** \_\_\_\_\_

**D.6 CHECK FOR JOINT LEAKAGE**

As soon as practical after main pump is started check all pump and piping joint connections for leakage. If any leaks are detected stop the main and booster system pump and repair leaks prior to proceeding with pump/system testing.

**Signature** \_\_\_\_\_ **Date** \_\_\_\_\_

## E. TROUBLESHOOTING

MALFUNCTION	POSSIBLE CAUSE	REMEDY
Loss of Flow or Low Capacity	System component malfunction	Inspect all system components. Correct any malfunctions. Insure that suction and discharge lines are open and all valves are in proper positions.
	Pump not primed or vented	Check reservoir oil level and fill as required. Vent air from pump.
	Low pump speed	Insure driver is not overloaded. For belt drives, insure belt not slipping. For variable speed drivers or variable speed intermediate devices, insure proper speed is set.
	Incorrect pump rotation	Correct direction of driver rotation.
	Obstruction in piping	Inspect all system piping and valves. Remove any obstructions.
	Wear of rotors and/or housings	Replace worn rotors, gears, and/or housing(s).
	System bypass	Check all system bypass valves, including relief valve. Repair or replace as required.
	Insufficient inlet pressure	Remove obstruction. Clean suction strainer or filter element.
Loss of Suction	Suction line closed, blocked or leaking	Verify suction line valve is locked open. Inspect suction line, especially joints. Remove any obstruction and repair any leaks. Clean strainer or replace filter.
	Excessive viscosity	Reduce viscosity by heating pump and/or system liquids.
	Dirty suction strainer	Clean or replace strainer or filter element.
	Wrong direction of rotation	Correct direction of driver rotation.
Low Discharge Pressure	Low liquid level in reservoir	Check liquid level in reservoir. Fill as necessary.
	Air in system	Insure pump is vented and suction lines are full of liquid.
	Worn rotors, gears, and/or housing(s)	Replace worn rotors, gears, and/or housing(s).
	Obstruction in piping	Inspect inlet piping and suction valve(s). Remove any obstruction(s).
	Dirty suction strainer	Clean/replace suction strainer or filter element.
	System bypass problem	Check all system bypass valves for leakage, including relief valves. Repair or replace as required.

<b>MALFUNCTION</b>	<b>POSSIBLE CAUSE</b>	<b>REMEDY</b>
Excessive or Unusual Noise or Vibration	Misalignment	Check pump and driver alignment and correct as required.
	Restricted suction line	Check suction line and remove any obstructions.
	Air in system	Insure pump is vented and suction lines are full of liquid. Check reservoir level. Fill as necessary. Check all lines, flanges, joints and connections for leakage. Repair as necessary.
	Dirty suction strainer	Clean suction strainer or filter element.
	Relief valve chatter or leakage	Check discharge relief valve pressure setting. Re-adjust, repair or replace relief valve.
	Heavy internal rubbing of pump parts	Verify pump and driver alignment. Inspect pump wearing parts. Replace as required.
	Mechanical problem	Check for loose or mis-positioned coupling, bent or broken shafts, or worn bearing. Repair or replace as required.
Rapid Pump Wear	Fluid contains abrasive foreign matter	Collect samples of liquid and test for foreign matter. Reduce downstream filter ratings in re-circulating systems (do not exceed NPIPR). If necessary, replace liquid in re-circulating systems.
	Fluid contains water	Remove any water from reservoir. Find source and prevent further ingestion.
	Misalignment	Check pump and driver alignment. Correct as required.
	Insufficient Liquid	Check liquid level in reservoir and correct as required. Remove any suction line obstructions. Clean/replace strainer or filter element.
Excessive Power Usage	Fluid more viscous than specified	Heat fluid to proper viscosity and/or design temperature.
	Pump suction and/or discharge lines closed or blocked	Insure suction and discharge lines are open, and remove obstructions if present.
	Heavy internal rubbing of pump parts	Verify pump and driver alignment. Inspect pump wearing parts. Replace as required.
	Excessive pump speed	Reduce pump speed to design limits.
	Mechanical problems	Check for bent shaft, tight shaft parking, or pipe strain. Repair or replace as required.

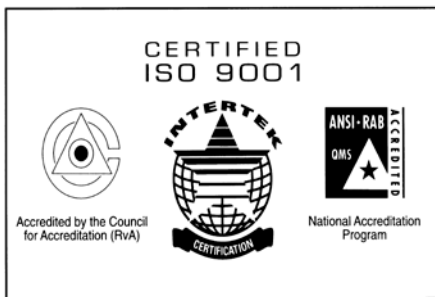

**COLFAX**  
Fluid Handling

**Imo Pump**

1710 Airport Road  
PO Box 5020  
Monroe, NC USA  
28111.5020

*Tel:* +1.704.289.6511

*Toll:* +1.877.853.7867

*Email:* [cc@colfaxcorp.com](mailto:cc@colfaxcorp.com)

*Web:* [colfaxcorp.com](http://colfaxcorp.com)

© 2012 Colfax Fluid Handling all rights reserved.

ALLWEILER® COT-PURITECH<sup>SM</sup> HOUTTUIN<sup>TM</sup> IMO® LSC<sup>SM</sup> ROSSCOR® TUSHACO® WARREN®