



**PRODUCT SERVICE MANUAL
FOR
G12D _ (S)-137 and 350 PUMPS**



WARNING

This Instruction Manual and General Instructions Manual, SRM00046, should be read thoroughly prior to pump installation, operation or maintenance.





Manual No. SRM00125

Rev. 00

May, 2014

READ THIS ENTIRE PAGE BEFORE PROCEEDING

FOR SAFETY OF PERSONNEL AND TO PREVENT DAMAGE TO EQUIPMENT, THE FOLLOWING NOMENCLATURE HAS BEEN USED IN THIS MANUAL:

	DANGER		
Failure to observe precautions noted in this box can result in severe bodily injury or loss of life.			
	WARNING		
Failure to observe precautions noted in this box can cause injury to personnel by accidental contact with equipment or liquids. Protection should be provided by user to prevent accidental contact.			
CAUTION		ATTENTION	
Failure to observe precautions noted in this box can cause damage or failure of equipment.			
Non compliance of safety instructions identified by the following symbol could affect safety for persons: 	Safety instructions where electrical safety is involved are identified by: 	Safety instructions which shall be considered for reasons of safe operation of pump and/or protection of pump itself are marked by the sign: ATTENTION	
ATTENTION			
If operation of pump is critical to your business, we strongly recommend you keep a spare pump or major repair kit in stock at all times. As a minimum, a minor repair kit (o-rings, gaskets, shaft seal and bearings) should be kept in stock so pump refurbishment after internal inspection can be accomplished.			

CONTENTS

Safety and Table of Contents	2
A. General Instructions	3
B. Introduction	3
C. Description of Equipment.....	3
D. Pump Model Identification	4
E. Ordering Instructions	4
F. Operation	5
G. Parts List	6
H. Pump Maintenance and Seal Drawing.....	7
I. Troubleshooting.....	11
J. Field and Factory Service and Parts.....	11
K. Assembly Drawings.....	12-14
L. Mechanical Seal Drawings	14

A. GENERAL INSTRUCTIONS

The instructions found herein cover the disassembly, assembly and parts identification of _G12D_-137 and 350 pumps.

NOTE: Individual contracts may have specific provisions that vary from this manual. Should any questions arise which may not be answered by these instructions, refer to the General Instructions Manual, SRM00046, provided with your order. For further detailed information and technical assistance please refer to Imo Pump, Technical/Customer Service Department, at (704) 289-6511.

This manual cannot possibly cover every situation connected with the installation, operation, inspection, and maintenance of equipment supplied. Every effort was made to prepare text of manual so that engineering and design data is transformed into the most easily understood wording. Imo Pump must assume personnel assigned to operate and maintain supplied equipment and apply this instruction manual have sufficient technical knowledge and are experienced to apply sound safety and operational practices which may not be otherwise covered by this manual.

In applications where equipment furnished by Imo Pump is to become part of processing machinery, these instructions should be thoroughly reviewed to ensure proper fit of said equipment into overall plant operational procedures.

	WARNING
If installation, operation, and maintenance instructions are not correctly and strictly followed and observed, injury to personnel or serious damage to pump could result. Imo Pump cannot accept responsibility for unsatisfactory performance or damage resulting from failure to comply with instructions.	

B. INTRODUCTION

This instruction manual covers series _G12D_-137 and 350 Imo pumps. This series of pumps has been designed for use in hydraulic, lubricating, seal, distillate, residual, fuel and crude oil applications. The model and design construction of each pump can be identified by the designator code on the pump nameplate. Definitions of model designators are identified in figure 1.

C. DESCRIPTION OF EQUIPMENT

G12D-137 and 350 series pumps are positive displacement, rotary screw pumps consisting of precision bored housings which enclose a driven screw (power rotor) and intermeshing following screws (idler rotors). These screws when rotating form a succession of closures or cavities. As they rotate, fluid is moved axially from inlet port to outlet port in a continuous, uniform flow with minimum fluid pulsation and pump noise.

D. PUMP MODEL IDENTIFICATION

This instruction manual covers Imo Series _G12D_-137 and 350 pumps. The model of each pump is identified on pump nameplate. Refer to figure 1 and table 1 for instructional keys when using this manual.

Figure 1 – Model Designator Definitions

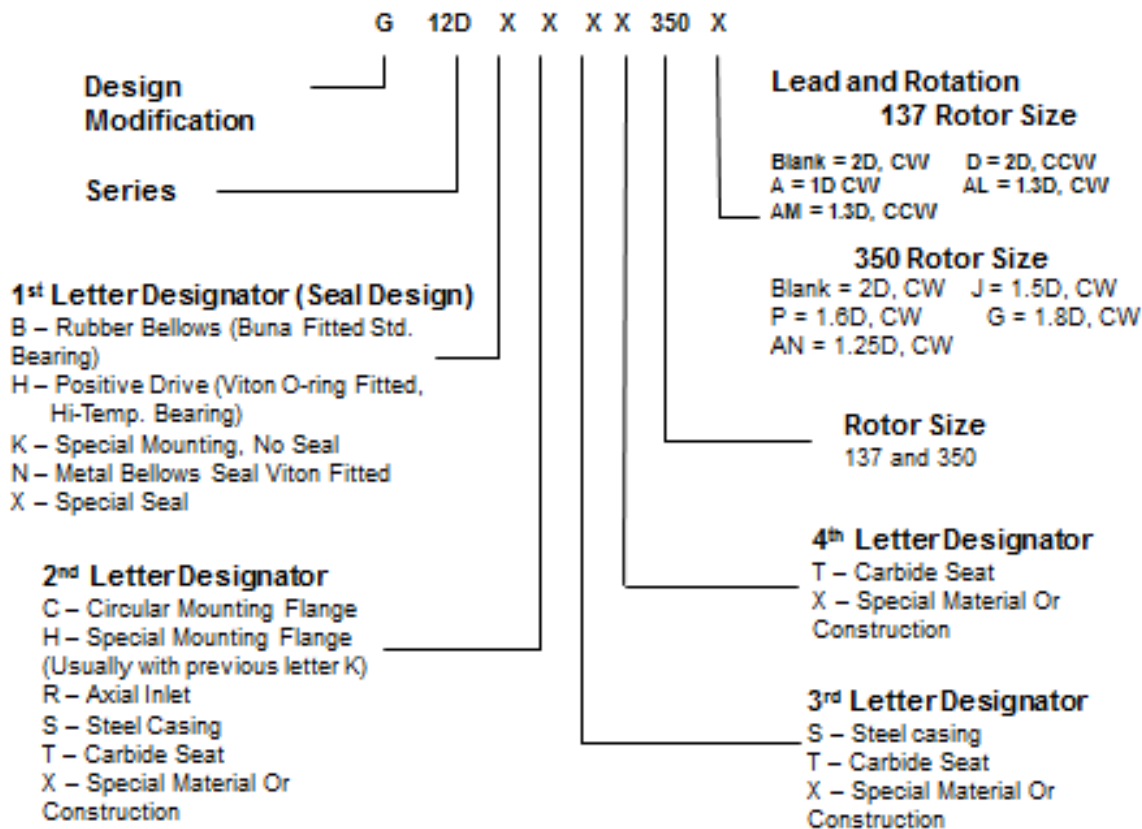

E. ORDERING INSTRUCTIONS

When corresponding with Imo Pump regarding Series _G12D_-137 and 350 pumps, refer to pump nameplate, this instruction manual, and assembly drawing as instructed below:

1. From pump nameplate, record pump model number, serial number, and manufactured date.
2. Record instruction manual number, revision, and date.
3. From instruction manual, record figure numbers that apply to replacement part(s).
4. From assembly drawing or parts list (see table 2) provide IDP number(s) and names for replacement part(s).
5. Give above information to your Imo service representative.

Imo sales and service representatives are listed herein and in General Instruction Manual, SRM00046.

F. OPERATION

F.1 LIQUID LIMITATIONS

CAUTION	ATTENTION
Never operate with water. Pump is designed for liquids having general characteristics of oil.	

F.2 OPERATING LIMITS

CAUTION	ATTENTION
<p>Operating conditions, such as speed, fluid viscosity, temperature, inlet pressure, discharge pressure, filtration, duty cycle, drive type, mounting, etc., are interrelated. Due to these variable conditions, specific application limits may be different from operational limitations. Equipment must not be operated without verifying system operating requirements are within pump's capabilities.</p>	

Under no circumstances are the following operating limits (specified in table 1) to be exceeded without specific approval from Imo Pump.

Table 1 – Normal Pump Operating and Structural Limits

Condition	Limit
Maximum Speed	4400 rpm for 137 size 2500 rpm for 350 size
Minimum Viscosity	32 SSU
Maximum Viscosity (figure 1)	
1 st Letter Designator B	2500 SSU
1 st Letter Designator H	20000 SSU
Minimum Liquid Temperature	0°F
Maximum Liquid Temperature (figure 1)	
1 st Letter Designator B	180°F
1 st Letter Designator H	220°F
Maximum Inlet Pressure	75 psig for 137 size 50 psig for 350 size
Maximum Discharge Pressure (Continuous Duty)	2200 psig
Filtration	Refer to General Instruction Manual, SRM00046
Drive	Direct or Belt
Mounting	Foot mounted in any attitude

G. PARTS LIST

Table 2 – Pump Parts List

IDP	QTY	DESCRIPTION	KIT	IDP	QTY	DESCRIPTION	KIT
1	1	Case		43	2	Bearing Retainer	
2	1	Inlet Head		46	1	Inboard Cover	
4	4	Cap Screws (Qty. 16 on 350 Size)		47	2	Bearing Retainer Hex Bolts	
5	2	Pipe Plug (137 C-Face Steel Case Only)		48	1	Seal Seat Adapter	
6	1	Pin Stop		49	1	Ball Bearing	X
7	1	Fastener Seal	X	63	1	Power Rotor	XX
8	2	Housing Snap Rings	XX	67	2	Pipe Plug	
9	2	Cover Gasket or O-rings	X	68	1	Tube Fitting (350 Size Only)	
21	2	Suction Idlers	XX	69	1	Pipe Nipple (350 Size Only)	
22	1	Balance Piston Housing (350 Size Only)	XX	70	1	Tubing Fitting	
23	2	Cups	XX	71	1	Seal Pipe	
24	1	Suction Housing	XX	73	3	Inlet Housing	XX
25	1	Mechanical Seal	X	74	1	Pipe Fitting	
26	3	Housing Tube (Qty. 4 on 350 Size)		83	1	Seal Gasket	X
27	8	Tube O-Rings	X	86	1	Balance Piston Bushing (137 C-Face Only)	X
28	2	Housing & BP O-Ring	X	90	4	Cap Screws (137 Size Only)	
29	1	Thrust Plate	XX	94	1	Shoulder Bolt (137 C-Face Only)	
31	1	Key		100	1	Oil Balance Tube	
35	6	Discharge Idlers	XX	101	2	Thrust Plate Spacer	
38	2	Seal Spacer (350 Size Only)		102	2	Thrust Plate Hex Bolt	
42	2	Bearing Retaining Rings	X				
X = Minor Repair Kit Items.							
XX = Major Repair Kit Items. (Items marked (X) are included in Major Repair Kit.)							

H. PUMP MAINTENANCE

	WARNING
Failure to observe precautions while installing, inspecting and maintaining pump can cause injury to personnel from accidental handling of liquids that may harm skin or clothing, or fire hazard risks from flammable liquids, or injury from high pressure fluid jets.	

	DANGER
BEFORE working on equipment, make sure all power to equipment is disconnected and locked-out.	

H.1 GENERAL COMMENTS

NOTE: Part number identifiers (IDP) contained within parenthesis, such as (9), refer to assembly drawing

De-energize driver before starting with any maintenance action.

H.2 TOOLS REQUIRED

Procedures described in this manual require common mechanics hand tools, a torque wrench, dial indicators for alignment and a suitable lifting device such as slings, straps, etc.

H.3 Pump Disassembly Procedure



CAUTION

Fluid leakage from disassembly of pump may make floor slippery and cause personal injury

NOTE: To service mechanical seal and ball bearing only, perform H.3, steps 1 thru 5 and H.4, Steps 13 through 18.

Refer to appropriate assembly drawings, Figures 3, 4 and 5, for the following instructions.

1. Close suction and discharge valves. Drain pump by removing drain plugs (67). Remove seal tubing (71). Remove pump from driver, coupling and base plate. Remove coupling hub and key (31).
2. Remove bearing retainer (43) from inboard cover (46) by removing bolts (47).
3. Remove assembled power rotor (63) from inboard cover (46). Removal of power rotor (63) includes removal of snap rings (42), ball bearing (49), seal (25), seal seat adapter (48) and, for 350 size spacer (38).

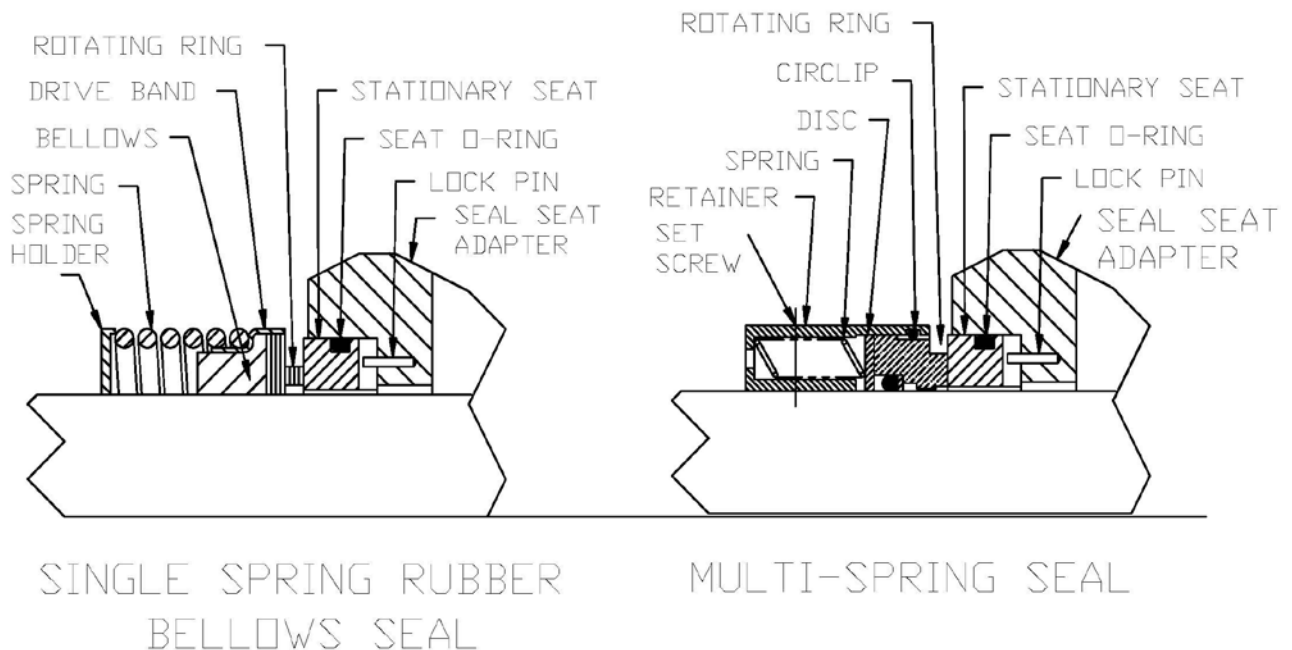

FIGURE 2 - SEAL DRAWING

4. Disassemble power rotor (63) as follows (See Figure 1 for seal drawings) :
 - a. Using a flat nosed tool, such as a screw driver, remove both snap rings (42) from groove in power rotor (63).
 - b. Sealed ball bearing (49) is assembled to power rotor (63) with light press fit. Ball bearing (49) may be removed by using bearing puller or vertical arbor press. When using press, place two pieces of key stock through openings of mechanical seal seat adapter (48) underneath ball bearing (49) on both sides of power rotor shaft. Key stock should be long enough to support power rotor (63) as it is placed in press. Position press ram against power rotor (63) coupling end face. Gently press power rotor (63) through ball bearing (49)

CAUTION		ATTENTION
Ensure power rotor (63) does not fall to floor once ball bearing (49) is off of its diameter		

- c. Remove seal seat adapter (48) with stationary seal seat. Remove stationary seat with O-ring from seal seat adapter (48). Discard O-ring.
 - d. If seal is multi-spring type, disengage set screw and remove rotating seal seat. If seal is a single spring rubber bellows type, remove it from shaft with a rotating motion.
 - e. Remove spacer (38) from shaft if size 350.
5. Remove seal gasket (83) from inboard end cover (46).
6. Remove inboard cover (46) by removing bolts (4).
7. If pump is a 137 size C-face type, remove O-ring (28) from inboard cover (46) shoulder bolt (94) from inboard cover (46) and balance piston bushing (22) from inboard cover (46).
8. If pump is 137 foot mount type or 350 size, remove gasket (9) from inboard cover (46).
9. Remove inlet head (2) from case (1) by removing bolts (4). Remove and discard gasket (9) from inlet head (2).
10. Remove thrust plate (29) and spacers (101) by removing bolts (102).
11. Remove seal return tube (100) with O-rings (27). Remove and discard O-rings (27).
12. Remove cups (23) from idlers (21) and idlers (21, 35) from housings (73, 24).

CAUTION		ATTENTION
Do not permit idlers (19) to drop as they emerge from housing (2).		

13. Remove snap rings (8) from case (1). Remove pin stop (6) with fastener seal (7) from case (1). Discard fastener seal (7)
14. If pump is a 350 size or 137 size foot mount , remove balance piston housing (22) by pushing it out through discharge end of case (1) with housings (73, 24). Remove and discard balance piston housing O-ring (28).

15. Remove housings (73, 24) by continuing to push them out through discharge end of the case (1). Remove and discard housing O-ring (28). Remove tubes (26) and O-rings (27) from housings (24 or 73). Discard O-rings (27)

CAUTION	ATTENTION
Do not permit housings (73, 24) to drop as they are removed from pump.	

H4. Pump Reassembly Procedure:

Note: Prior to reassembly, all parts should be cleaned and inspected for nicks and burrs. Replace all worn and damaged parts. Imo pump recommends replacement of ball bearing (49), mechanical seal (25), gaskets (9, 83, 6), fastener seal (7) and O-rings (28) when these parts are disturbed from their original installed position. All parts should be coated with light lubricating oil to assist in assembly.

1. Install O-ring (28) in groove in housing (24). Install O-rings (27) in grooves in all but one tube (26 and 100). Install a tube (26) with O-rings (27) in housing (24) on opposite side of housing O-ring (28).
2. Install housing (24), O-ring end first, in pump case (1) from suction end until stop pin (6) slot is properly aligned. Install stop pin (6) with fastener seal (7) in case (1).
3. Inlet 1st inlet housing (73) in pump case (1) with end that has two drilled and tapped holes facing inlet end of pump. Be sure that tube (26) in housing (24) mates to hole in housing (73).
4. Install tube (26) with O-rings (27) in back side of first inlet housing (73) and then install second inlet housing (73) being sure that tube (26) in first housing (27) mates to hole in second housing (73).
5. Repeat step 4 with last inlet housing (73)
6. Install snap rings (8) in case (1).
7. If pump is 350 size, proceed below. If not skip to step 12.
8. Install tube (26) without O-rings (27) in discharge housing (24) side facing outlet side of pump and install O-ring (28) on balance piston housing (22).
9. Install balance piston housing (22) in pump case being sure that idler stops on balance piston housing (22) are lined up with idler bores and pin hole in balance piston housing (22) lines up with pin (26) on discharge housing (24)
10. Install gasket (9) on inboard cover.
11. Install inboard cover (46) in case (1) using bolts (4). Ensure seal vent (70) is facing up. Torque bolts (4) to value on appropriate assembly drawing. Skip to step 16
12. If pump is 137 size, C-face type, install balance piston bushing (86) in inboard cover (46) with shoulder bolts (94), O-ring (28) in inboard cover (46) and inboard cover (46) in case (1) with bolts (90). Torque bolts to value on assembly drawing. Ship to step 16.
13. If pump is 137 size, foot mount type, proceed below.

14. Install O-ring (28) on balance piston housing (22). Install balance piston housing (22) onto inboard cover (46) being sure that roll pin in balance piston housing (22) mates to slit in inboard cover (46).
15. Install inboard cover (46) / balance piston housing (22) assembly in case with bolts (90) being sure that seal drain (70) in inboard cover (46) is positioned at 12 o'clock. Torque bolts (4) to value on appropriate assembly drawing
16. Assemble power rotor (63) and mechanical seal (25) as follows (See Figure 1 for seal drawings):
 - a. If size 350, assemble seal spacer (38) onto shaft (63).
 - b. If seal is a single spring rubber bellows type, apply light coat of system fluid to inside diameter of bellows and slide mechanical seal rotating assembly on power rotor (63) until it seats against the shoulder of seal spacer (38). Wipe seal face with isopropyl alcohol and a lint free rag.
 - c. If seal is a multi-spring seal, coat O-ring inside of rotating seat with system fluid and slide mechanical seal rotating assembly on power rotor (63) until it seats against the shoulder of seal spacer (38). Tighten rotating seat set screw. Wipe seal face with isopropyl alcohol and a lint free rag.
 - d. Install O-ring in groove of mechanical seal stationary seat. Install seat including O-ring in seal seat adapter (48) ensuring that slot in back of stationary seat mates to spring pin in seal seat adapter (48). Clean seal face with isopropyl alcohol and a lint free rag. Put a small amount of clean system fluid or light oil on seal running face. Install the stationary seat running face against the rotating seat face.
 - e. Install inner snap ring (42) in groove of power rotor (63).
 - f. Press bearing (49) on power rotor (63), pressing only on inner race of ball bearing (49) using an installation sleeve until it is located next to inner snap ring (42).

CAUTION	ATTENTION
----------------	------------------

Bearing service life could be significantly reduced if bearing is pushed on by its outer race.

- g. Install outer snap ring (42) in groove of power rotor (63).
17. Install gasket (83) in seal bore of inboard cover (46).
18. Install assembled power rotor (63) in pump, centering all parts as they enter inboard cover (46). Align one of openings in spacer (48) over drain in inboard cover (46).
19. Install bearing retainer (43) on inboard cover (46) using bolts (47). Torque bolts (47) to value on appropriate assembly drawing.
20. Install idlers (35 and then 21) into housings (24, 73) by meshing threads with power rotor thread
21. Install cups (23) on idlers (21).
22. Install bolts (102) in thrust plate (29) and spacers (101) on bolts (102).

23. Install thrust plate assembly including thrust plate (29), bolts (102) and spacers (101) on housing (73). Torque bolts (102) to value on appropriate assembly drawing.

24. Install gasket (9) in groove in inlet head (2), and install inlet head (2) on case (1) using hex bolts (4). Torque bolts (4) to value on appropriate assembly drawing

NOTE: Inlet head (2) can be rotated and repositioned in 90 degree increments to suit suction piping. To change inlet position remove bolts (4) and rotate inlet head to desired position. Install bolts (4) and torque to proper values indicated on assembly drawing.

25. Install coupling hub key (16). Install and align pump and driver as specified in General Instruction Manual, SRM00046.

I. TROUBLESHOOTING

For assistance with troubleshooting see the General Instruction Manual, SRM00046.

J. FIELD AND FACTORY SERVICE AND PARTS

Imo Pump maintains a staff of trained service personnel that can provide pump installation, pump start-up, maintenance/overhaul and troubleshooting supervision as well as installation and maintenance training.

Our factories provide maintenance as well as overhaul and test facilities in the event user prefers to return pumps for inspection or overhaul. Factory-overhauled pumps are normally tested and warranted "as-new" for a period of one year from date of shipment. For either field service or factory overhaul assistance, contact your local Imo Sales Office or representative at Technical/ Customer Service Department in Monroe, NC, USA.

Most pumps have repair kits available. Minor Repair Kits are used to repair leaking seals, bad bearings and/or for re-assembly after pump tear-down. They include pump shaft seals all gaskets/O-rings and bearings. Major Repair Kits are sufficient to rebuild completely worn-out pumps to "as-new" condition. They include all parts found in Minor Repair Kits plus all major internal parts subject to wear. Since kits have all necessary parts, kit purchase is preferred rather than selecting individual parts. When parts are individually selected from Parts List, some needed components are often overlooked. In addition, mixing worn or used parts with new parts risks rapid wear and shortened service life from new parts.

FIGURE 3

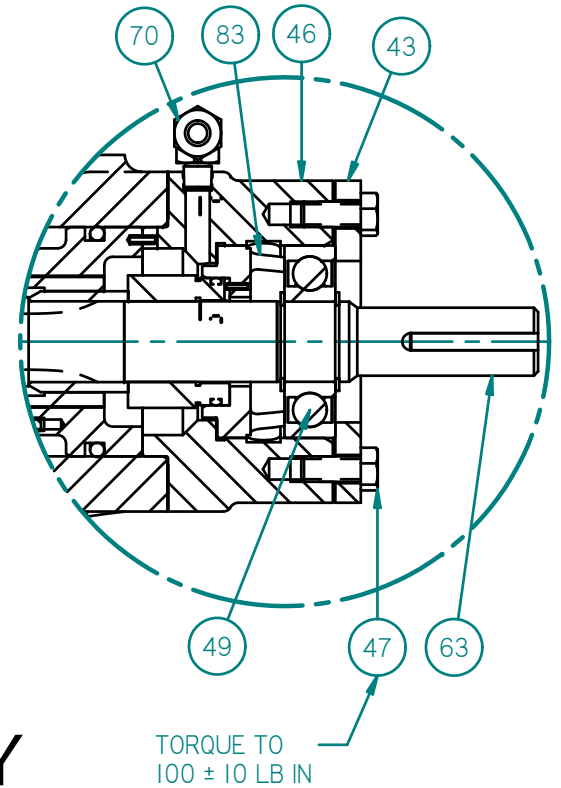
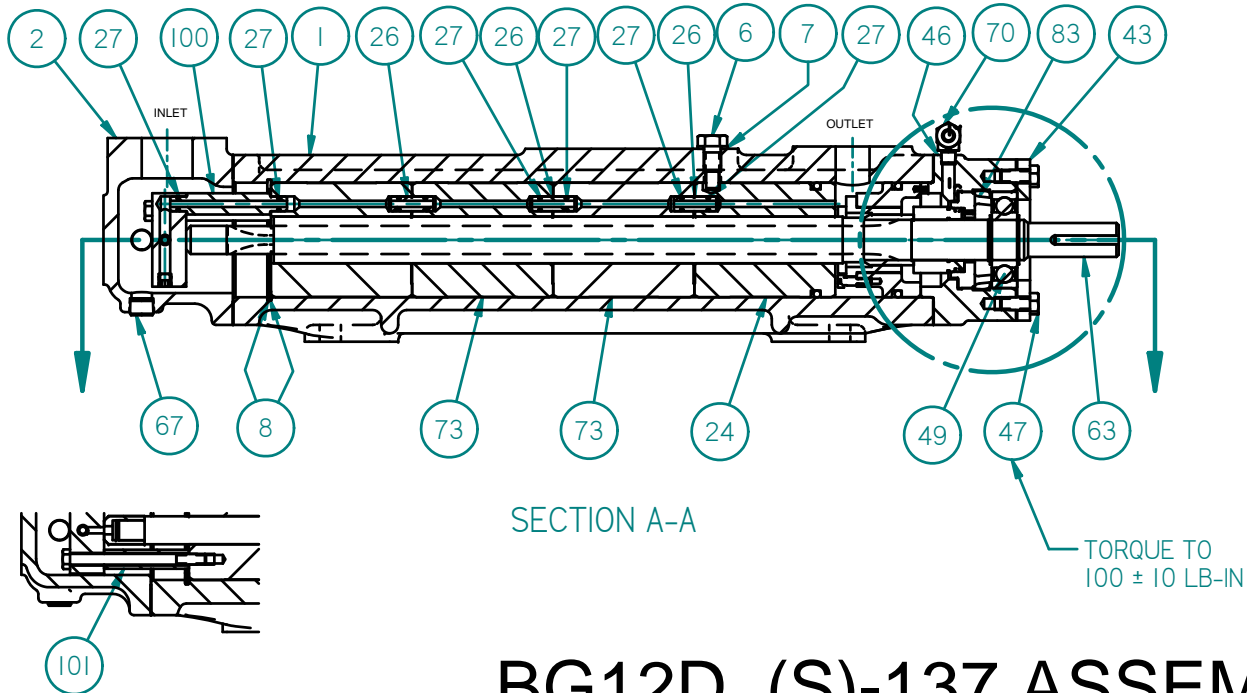
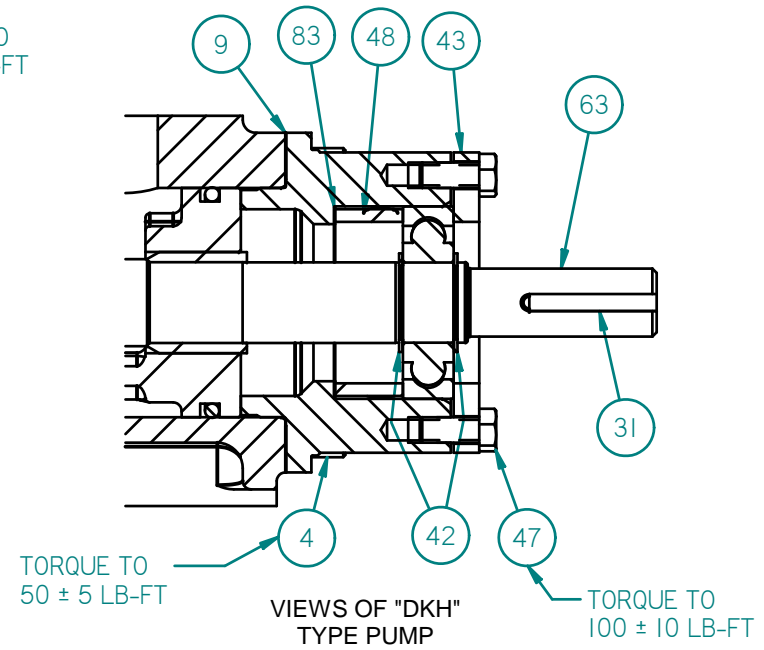
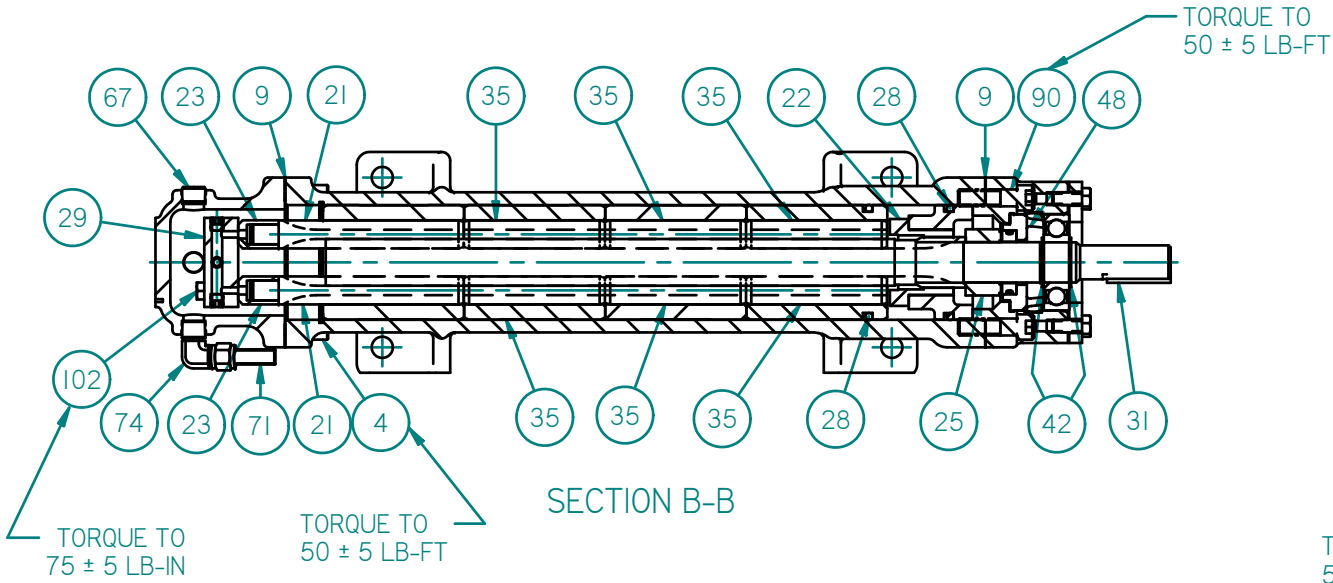

BG12D_(S)-137 ASSEMBLY

FIGURE 4

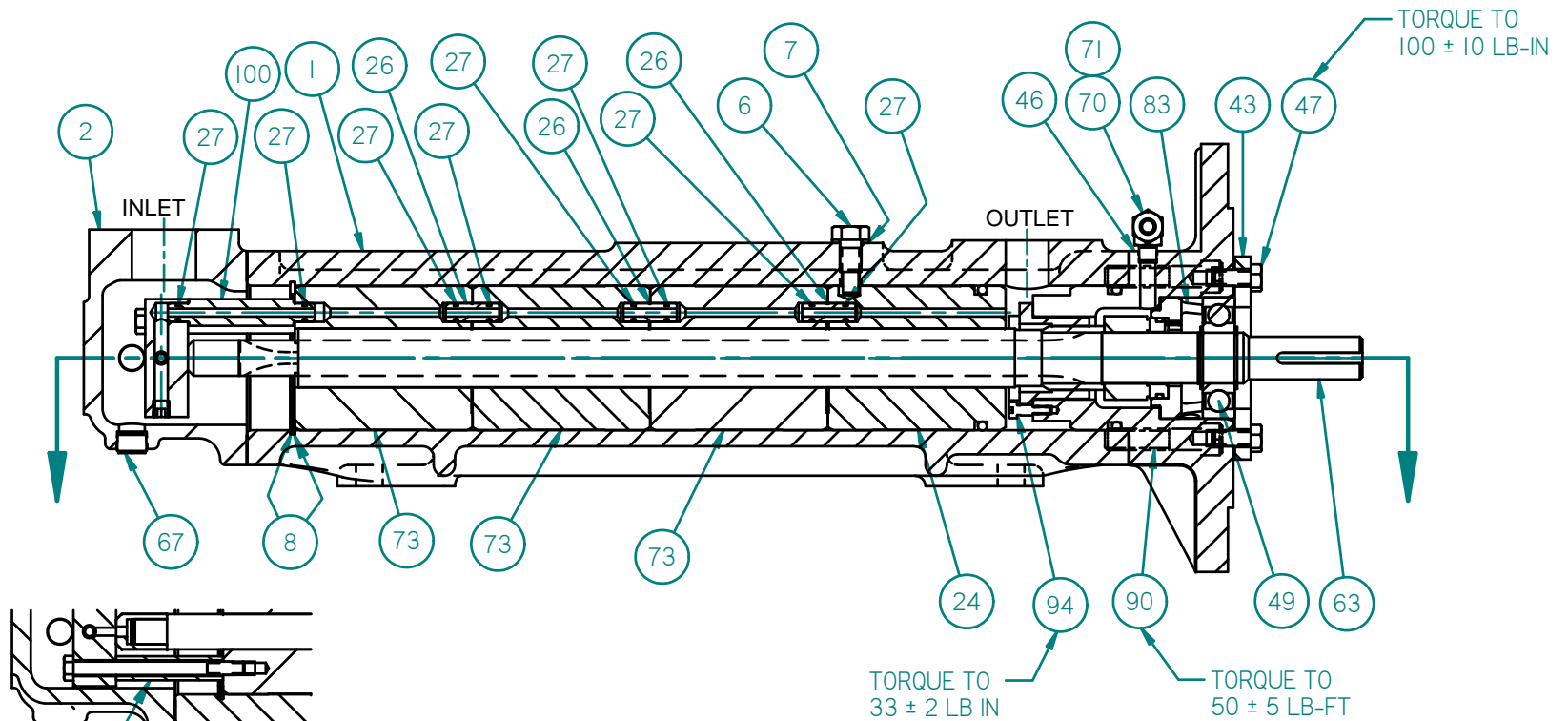
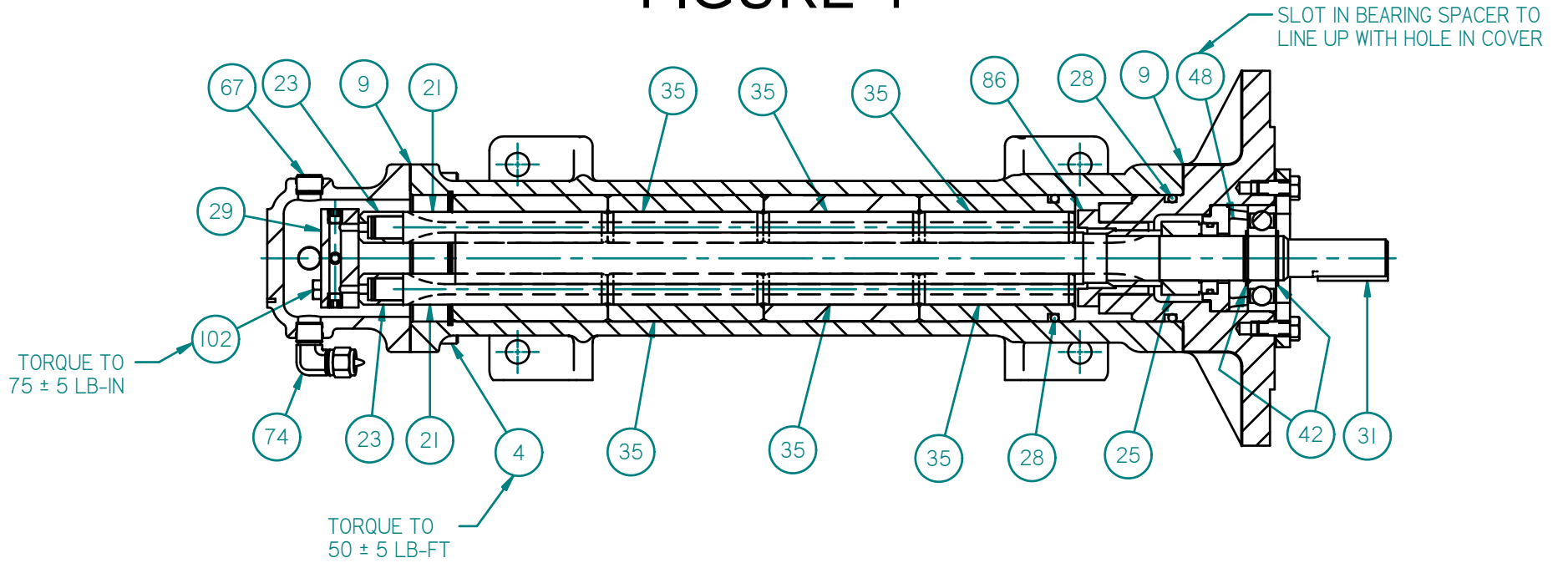

G12D_C(S)-137 ASSEMBLY

FIGURE 5

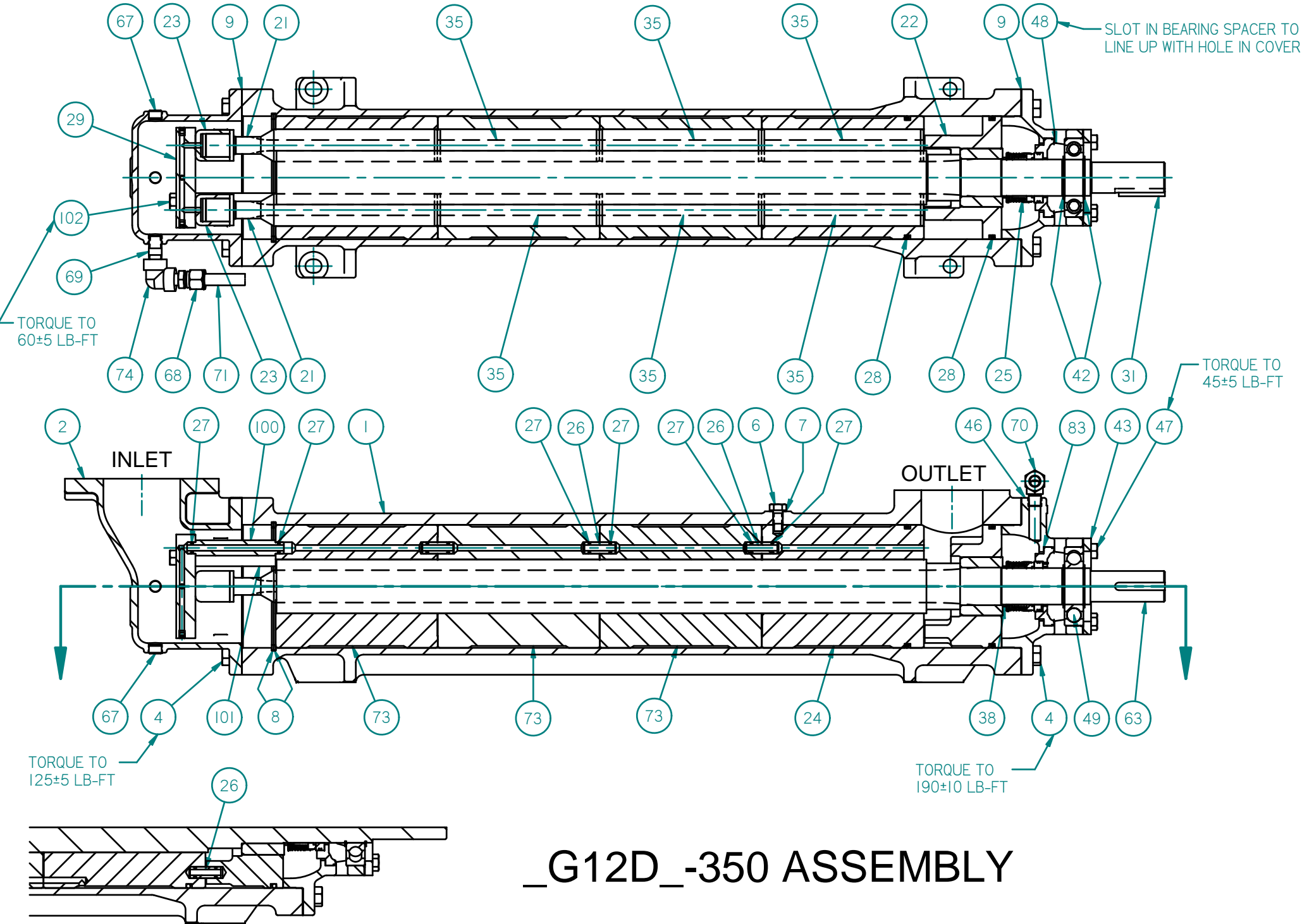

G12D-350 ASSEMBLY

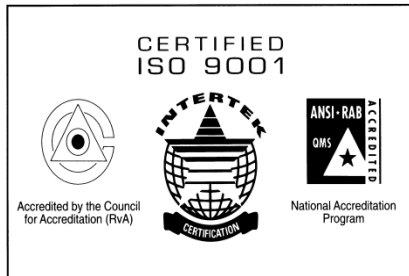

Imo Pump

1710 Airport Road
PO Box 5020
Monroe, NC USA
28111.5020

Tel: +1.704.289.6511

Toll: +1.877.853.7867

Email: cc@colfaxcorp.com

Web: colfaxcorp.com

COLFAX
Fluid Handling

© 2012 Colfax Fluid Handling all rights reserved.

ALLWEILER® COT-PURITECHSM HOUTTUINTM IMO® LSCSM ROSSCOR® TUSHACO® WARREN®