

✓	ITEM NO.	NEMA MOTOR FRAME	UNITS	A	B	C	D	E	F	G	G	H	J	K	L	M	N	P	R	T	V	W	Y	APPROX. UNIT WT. LB/[kg]	COUPLING MODEL NO.
										MTR. FT. MOUNT	BRACKET MOUNT														
	001	56C	INCHES [mm]	27.0 [687]	7.1 [179]	3.50 [89]	0.69 [18]	11.25 [286]	4.5 [114]	3.4 [87]	4.5 [114]	---	0.13 [3]	0.50 [13]	4.0 [102]	1.75 [44]	2.44 [62]	6.5 [165]	3.00 [76]	0.34 [9]	11.5 [292]	1.5 [38]	8.9 [227]	71 [32]	L150
	002	143/145TC	INCHES [mm]	26.1 / 26.6 [662 / 675]	7.3 [184]	3.50 [89]	0.69 [18]	11.25 [286]	4.5 [114]	3.4 [87]	4.5 [114]	---	0.40 [10]	0.50 [13]	6.0 [152]	1.25 [32]	2.75 [70]	7.0 [178]	4.00 / 5.00 [102 / 127]	0.34 [9]	11.8 [300]	2.0 / 2.5 [51 / 64]	8.9 [227]	106 [48]	L150
	003	182/184TC	INCHES [mm]	29.1 / 29.6 [740 / 752]	9.9 [251]	4.50 [114]	---	---	---	---	---	9.3 [235]	0.50 [13]	1.50 [38]	8.5 [216]	1.80 [46]	3.75 [95]	9.0 [229]	4.50 / 5.50 [114 / 140]	0.41 [10]	12.2 [310]	2.3 / 2.8 [57 / 70]	---	135 [61]	L095
	004	213/215TC	INCHES [mm]	32.9 / 33.6 [835 / 854]	11.3 [286]	5.25 [133]	0.56 [14]	11.25 [286]	4.5 [114]	4.5 [114]	4.5 [114]	---	0.70 [18]	1.06 [27]	9.1 [232]	2.00 [51]	4.25 [108]	10.5 [267]	5.50 / 7.00 [140 / 178]	0.41 [10]	14.5 [369]	2.8 / 3.5 [70 / 89]	8.9 [227]	190 [86]	L110
	005	254/256TC	INCHES [mm]	36.2 / 37.1 [920 / 943]	13.4 [340]	6.25 [159]	0.56 [14]	11.25 [286]	4.5 [114]	4.5 [114]	4.5 [114]	---	0.80 [20]	1.25 [32]	12.5 [318]	2.65 [67]	5.00 [127]	12.5 [318]	8.25 / 10.00 [210 / 254]	0.53 [13]	15.0 [381]	4.1 / 5.0 [105 / 127]	8.9 [227]	280 [127]	L110
	006	284/286TSC	INCHES [mm]	37.6 / 38.3 [954 / 973]	14.8 [376]	7.0 [178]	0.56 [14]	13.0 [330]	5.6 [143]	5.6 [143]	5.6 [143]	---	0.80 [20]	1.50 [38]	14.0 [356]	2.80 [71]	5.50 [140]	14.0 [356]	9.50 / 11.00 [241 / 279]	0.53 [13]	14.4 [365]	4.8 / 5.5 [121 / 140]	11.3 [286]	394 [179]	L150
	007	324/326TSC	INCHES [mm]	40.4 / 41.2 [1027 / 1046]	16.6 [422]	8.0 [203]	0.69 [18]	16.0 [406]	7.0 [177]	7.0 [177]	7.0 [177]	---	0.90 [23]	1.75 [44]	15.5 [394]	3.2 [81]	6.25 [159]	16.0 [406]	10.50 / 12.00 [267 / 305]	0.66 [17]	15.4 [391]	5.3 / 6.0 [133 / 152]	13.9 [354]	488 [222]	L150
	008	364/365TSC	INCHES [mm]	42.6 / 43.6 [1081 / 1107]	18.5 [470]	9.0 [229]	0.69 [18]	16.0 [406]	7.0 [177]	7.0 [177]	7.0 [177]	---	1.00 [25]	1.98 [50]	16.2 [411]	4.0 [102]	7.00 [178]	18.0 [457]	11.25 / 12.25 [286 / 311]	0.66 [17]	16.0 [407]	5.6 / 6.1 [143 / 155]	13.9 [354]	755 [343]	L150

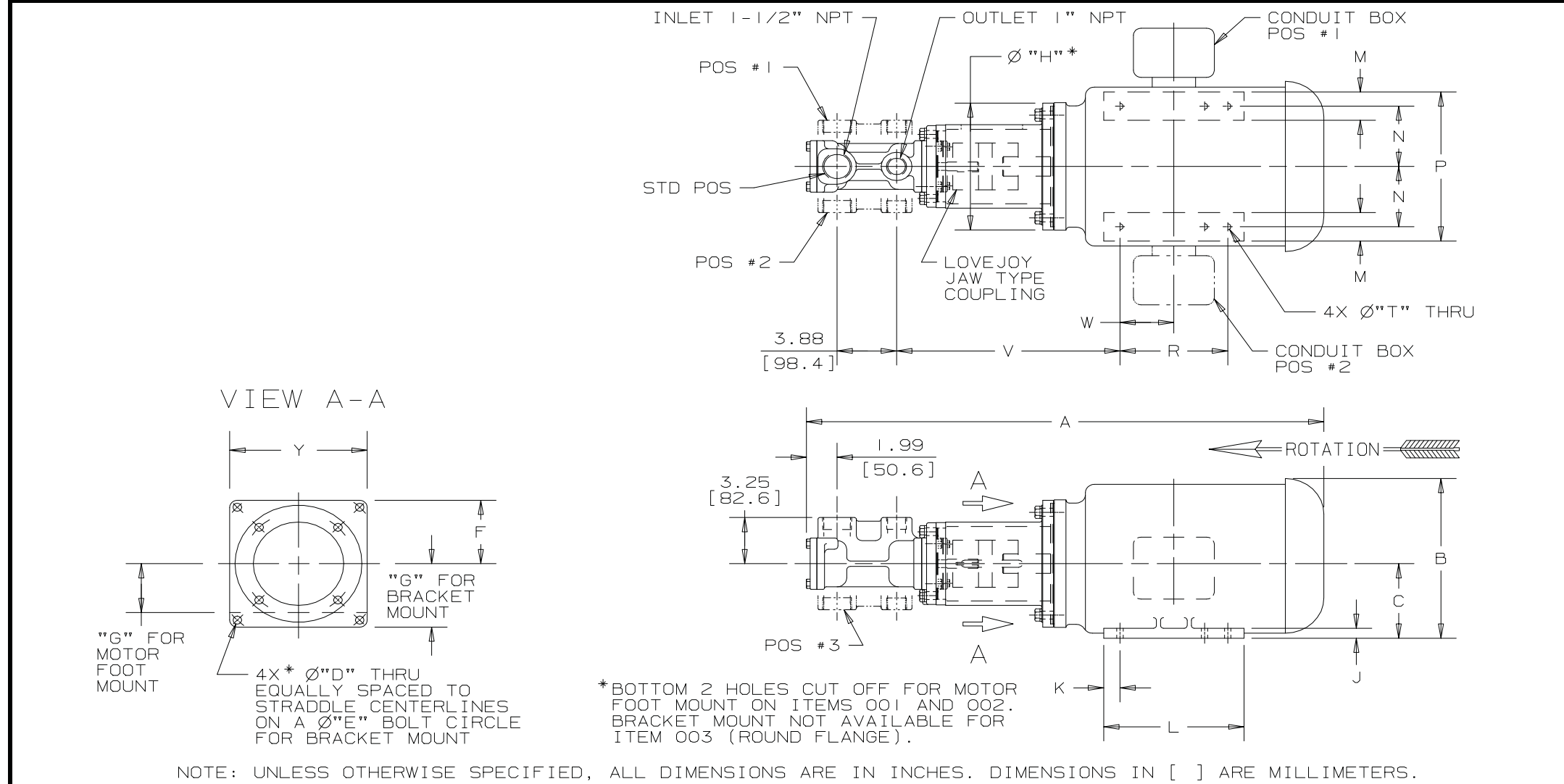

DRAWING CERTIFICATION

CUSTOMER NAME -----

CUSTOMER PO NUMBER ----

CUSTOMER PART NUMBER --

UNIT BILL OF MAT'L NO. --

PUMP TYPE -----

ITEM NUMBER -----

MOUNT TYPE -----

SHAFT ROTATION -----

PORT POSITION -----

MOTOR MANUFACTURER ----

MOTOR TYPE -----

FRAME SIZE -----

POWER -----

ROTATING SPEED -----

PHASES -----

FREQUENCY -----

VOLTAGE -----

MOTOR WEIGHT -----

CONDUIT BOX POSITION --

MOTOR INSTALLED BY ----

CERTIFIED BY -----

CERTIFICATION DATE ----

IMO ORDER NUMBER -----

CERTIFICATION REV. NO. --

NOTES:

MAX. ALLOWABLE FORCES & MOMENTS ON PORTS

- COORDINATE SYSTEM FOR MAXIMUM PORT FORCES (F) AND MOMENTS (M).

- FORCE AND MOMENT VALUES ARE RELATIVE TO CENTER OF INLET AND OUTLET PORT FACES.

	FORCE	LB-F	[N]	MOMENT	LB-FT	[N m]
INLET	FX	28.1	[125]	MX	46.9	[63.6]
	FY	28.1	[125]	MY	46.9	[63.6]
	FZ	28.1	[125]	MZ	46.9	[63.6]
OUTLET	FX	18.8	[83.4]	MX	31.3	[42.4]
	FY	18.8	[83.4]	MY	31.3	[42.4]
	FZ	18.8	[83.4]	MZ	31.3	[42.4]

- NOTES --
- THIS IS A STANDARD PRE-ENGINEERED UNIT OUTLINE. ANY CHANGES OUTSIDE THE CERTIFICATION BLOCK WILL REQUIRE A NEW DRAWING ASSIGNMENT.
 - ALTERNATE PORT POSITIONS ARE PROVIDED IF SPECIFIED ON ORDER. AVAILABLE POSITIONS ARE STD, #1, #2 & #3.
 - DRIVER DIMENSIONS MAY VARY WITH TYPE AND MAKE OF DRIVER.
 - STANDARD SHAFT ROTATION IS CLOCKWISE WHEN FACING COUPLING END OF PUMP.
 - REVIEW GENERAL INSTRUCTION MANUAL FOR ALIGNMENT, PIPING, INLET STRAINER, DISCHARGE RELIEF VALVE, SEAL, VENT, ETC., CONSIDERATIONS BEFORE INSTALLING AND OPERATING UNIT.

REV. NO.	ECR NO.	DATE	APPROVED BY

CIRCOR | IMO®

DRAWN BY	DATE	APPROVED BY	DATE
D.Mashburn	5/11/01	M.Vena	5/11/01
CHECKED BY	DATE	FIRST ORDER NUMBER	
M.Vena	5/11/01	EB122A	

STANDARD UNIT OUTLINE DRAWING

IRON CASE FLANGE MOUNT 3E118

CAGE CODE	DWG SIZE	SHEET	DRAWING NUMBER
59180	B	1 of 1	SDD20074