



IMO[®]

**INSTRUCTION MANUAL
AND
PARTS LIST
FOR
3E SERIES PUMPS
ROTOR SIZES 87, 87P AND 95**



WARNING

The Imo General Installation, Operation, Maintenance and Troubleshooting Manual, (No. SRM0046) along with this manual and all other component manuals supplied with these type units should be read thoroughly prior to pump installation, operation or maintenance.

MANUAL NO. SRM00016

REV. 08 (19-0443)

Dec, 2019



READ THIS ENTIRE PAGE BEFORE PROCEEDING

FOR SAFETY OF PERSONNEL AND TO PREVENT DAMAGE TO EQUIPMENT, THE FOLLOWING NOMENCLATURE HAS BEEN USED IN THIS MANUAL:

| | | |
|--|---------------|--|
|  | DANGER | |
| Failure to observe precautions noted in this box can result in severe bodily injury or loss of life. | | |

| | | |
|--|----------------|--|
|  | WARNING | |
| Failure to observe precautions noted in this box can cause injury to personnel by accidental contact with equipment or liquids. Protection should be provided by user to prevent accidental contact. | | |

| | | |
|--|------------------|--|
| CAUTION | ATTENTION | |
| Failure to observe precautions noted in this box can cause damage or failure of equipment. | | |

| | | |
|--|---|---|
| Non compliance of safety instructions identified by the following symbol could affect safety for persons:  | Safety instructions where electrical safety is involved are identified by:  | Safety instructions which shall be considered for reasons of safe operation of the pump and/or protection of the pump itself are marked by the sign: <div style="text-align: center;">ATTENTION</div> |
|--|---|---|

CONTENTS

| | |
|--|--------|
| Safety and Table of Contents | 2 |
| General Instructions | 3 |
| Introduction | 3 |
| Pump Model Identification | 4 |
| Operating | 4 |
| Type 8VO Mechanical Seal | 5 |
| Maintenance, Bearing & Seal Installation | 5-6 |
| Disassembly and Assembly Instructions | 6-7 |
| Spare Parts and Kits..... | 8 |
| Ordering Instructions | 8-9 |
| Pump Assembly Drawings..... | 9 - 13 |

| |
|--|
| ATTENTION |
| <i>If operation of this pump is critical to your business, we strongly recommend you keep a spare pump or major repair kit in stock at all times. As a minimum, a minor repair kit (o-rings, gaskets, shaft seal and bearings) should be kept in stock so pump refurbishment after internal inspection can be accomplished.</i> |

GENERAL INSTRUCTIONS

Instructions given herein cover generally operation and maintenance of subject equipment. Should any questions arise which may not be answered specifically by these instructions, they should be referred to Imo Pump for further detailed information and technical assistance.

This manual cannot possibly cover every situation connected with operation, adjustment, inspection, test, overhaul and maintenance of equipment furnished. Every effort is made to prepare text of manual so that engineering and design data is transformed into most easily understood wording. Imo Pump, in furnishing this equipment and this manual, must presume that operating and maintenance personnel assigned thereto have sufficient technical knowledge and experience to apply sound safety and operational practices which may not be otherwise covered herein.

In applications where Imo Pump furnished equipment is to be integrated with a process or other machinery, these instructions should be thoroughly reviewed to determine proper integration of equipment into overall plant operational procedures. On critical or dangerous equipment, provide suitable safety and emergency systems to protect personnel and property from injury due to pump malfunction. If pump handles flammable, toxic, corrosive or explosive fluids, provide for safety in event of pump leakage or malfunction.

| | |
|---|----------------|
|  | WARNING |
| <p>If installation, operation and maintenance instructions are not correctly and strictly followed and observed, injury to personnel or serious damage to pump could result. Imo Pump cannot accept responsibility for unsatisfactory performance or damage resulting from failure to comply with instructions.</p> | |

INTRODUCTION

Instruction manual covers 3E-87 and 95 Series pumps. Specific models covered by this manual are identified in Table 1. Model of each particular pump is identified on pump end cover. Refer to Figure 1 for definition of model designator. Refer to assembly drawing corresponding to your pump model, Figures 3 through 8, as you use this instruction manual.

Table 1 – 3E Series Pump Models

| ROTOR SIZES - 87, 87P AND 95 (1) | | | | | |
|---|-------------------|-----------------------|-----------------------------------|-----------------------|-----------------------------------|
| PUMP MODEL (1) | FIGURE NO. | PUMP MODEL (1) | FIGURE NO. | PUMP MODEL (1) | FIGURE NO. |
| D3EBC | 3 | D3EBSTCS | 6 | D3EVC | 3 |
| D3EBVS | 6 | D3EBTCS | 6 | D3EVF | 5 |
| D3EBCXF | 3 | D3EBTFS | 8 | D3EX | No replacement parts kits offered |
| D3EBF | 5 | D3EIC | No replacement parts kits offered | D3ECXS | 6 |
| D3EBFS | 8 | D3EICS | 7 | D3EXS | 6 |
| (1) Pump Model letters precede rotor size. | | | | | |

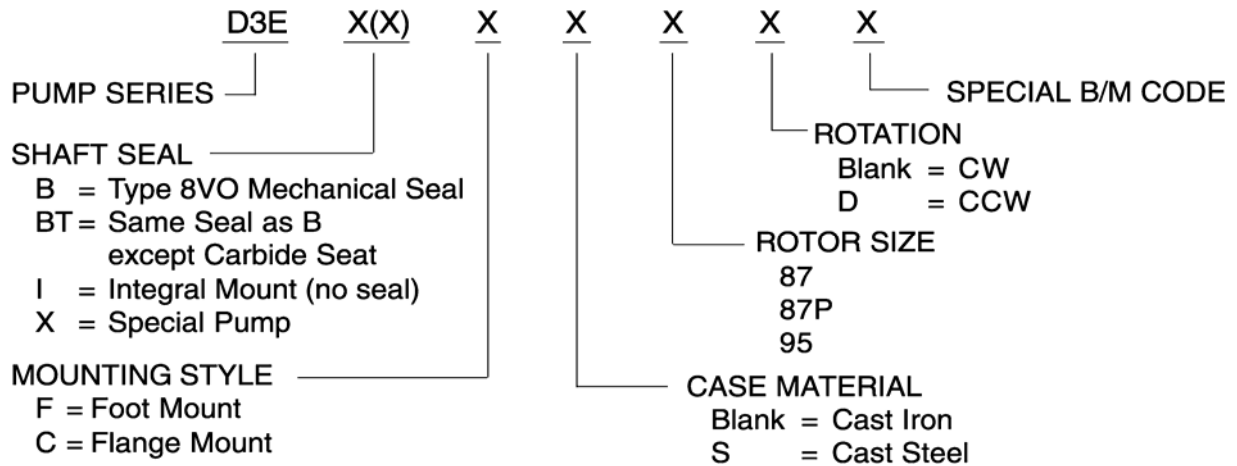

Figure 1 – Definition of Model Designators of D3E Series Pumps

OPERATING LIMITS

| CAUTION | ATTENTION |
|--|-----------|
| <p>Operating conditions, such as speed, fluid viscosity, temperature inlet pressure, discharge pressure, filtration, duty cycle, drive type, mounting, etc., are interrelated. Due to these variable conditions, specific application limits may be different from operational limitations. Equipment must not be operated without verifying system's operating requirements are within pump's capabilities.</p> | |

Pump Weights: C-Face and Integral Mount for both 87 and 95 sizes = 9 Lb [4 kg]
Foot Mount = 10.2 LB [5 kg]

Pump Airborne Noise levels are expected to be less than 70 dBA.

Table 2 – Pump Operating and Structural Limits

| | |
|----------------------------------|---|
| Maximum Speed..... | 3600 Rpm for Atex applications. Contact factory for higher speeds. For #6 fuel oil, crude oil and fluids known to contain fine abrasives, pump speed should not exceed 1800 RPM. |
| Viscosity | 2.0 cst (33 SSU) Minimum 648 Cst (3000 SSU) max. for type B seal. 5400 Cst (25,000 SSU) max. for type H seal |
| Temperature | Mechanical Seal Pumps, 0° to 180°F [-17.8 C to 82.2 C] Integral Mounted Pumps, 0° to 250°F [-17.8 to 121 C] |
| Suction..... | 25 PSIG Maximum [1.72 bar Maximum] |
| Drive | Direct Only |
| Maximum Discharge Pressure | 150 PSIG [10.3 bar] |
| Filtration..... | Light Fluids – 60 mesh Heavy Fluids – 1/16 to 1/8 inch [1.58 mm to 3.18 mm] |

MECHANICAL SEAL

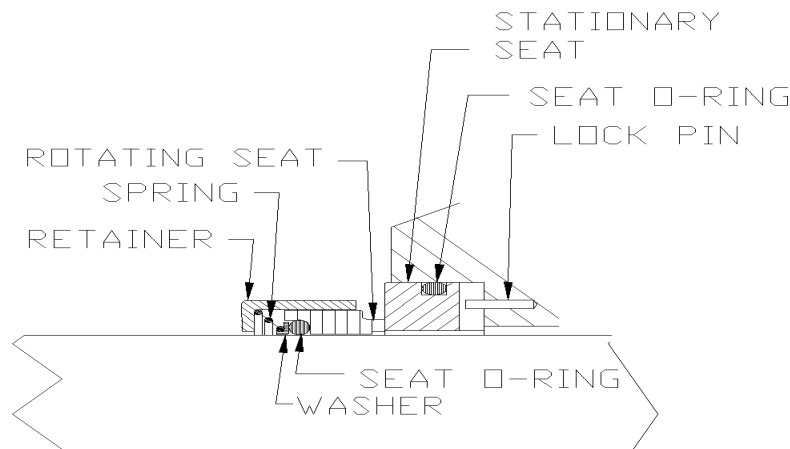

Figure 2 – Type 8VO Mechanical Seal

Type 8VO Mechanical Seals are installed in pump models D3EBC(S), D3EBTC(S), D3EBF(S) and D3EXCS-87-501. Integral mounted D3EIC(S) and D3EX pumps are not fitted with a mechanical seal. Figure 2 is an illustration of the Type 8VO Mechanical Seal.

MAINTENANCE

GENERAL

To perform maintenance on Series 3E pumps, following conditions shall be completed prior to maintenance action: Close inlet and outlet valves and tab "Out of Service". De-energize pump drive motor controller and tag "Out of Service". Vent all pressure from pump housing. Remove pump from driver and remove coupling from pump. Remove coupling key (13).

SERVICING SEAL AND BEARING (refer to Figure 3, 5, 6 or 8)

REMOVAL OF SEAL AND BEARING

Complete GENERAL steps, then remove retainer bolts (6) and retainer (12). Grasp power rotor (7) and pull the assembled power rotor (7) and cover (4) with idlers (8) from pump. Remove O-ring (31) from either cover or pump. Disassemble cover and power rotor assemblies as follows:

- a. Pull assembled power (7) from cover (4). Remove Truarc ring (15) from power rotor. Support seal seat adapter subassembly (25) and press power rotor (7) down through ball bearing (11). Slide rotating parts (3, Figure 2) of mechanical seal (16) off power rotor (7).
- b. Pull mechanical seal seat (Figure 2) with O-ring (Figure 2) from seal seat adapter subassembly (25) and remove O-ring from seat, if required. Remove gasket (26) from cover (4) and clean all internal surfaces of cover (4), bearing and seal bore.

INSTALLATION OF SEAL AND BEARING

Clean and inspect each part for burrs or nicks. Using a buffing wheel, remove all burrs. Particular attention must be given to keyway and Truarc ring groove of power rotor (7) to ensure all sharp edges are removed. Sharp edges on power rotor (7) keyway and truarc ring may cut or shave mechanical seal O-ring (Figure 2) when it is placed into installed position. Wipe all parts with lubricating oil (SAE-30) prior to installing.

- a. With power rotor (7) and mechanical seal rotating assembly (Figure 2) coated with lubricating oil, slide the rotating assembly (Figure 2) on power rotor (7). To start rotating assembly on power rotor, gently push on primary ring (Figure 2) face with thumb or a three finger grip on primary ring, rocking assembly slightly until it starts to slide on power rotor. DO NOT allow assembly to rotate as it slides past the keyway groove. With rotating assembly slid past power rotor keyway assembly may be rotated as it is slid into position next to idler stop (9). Rotating assembly is correctly installed when driving flats on retainer (Figure 2) are fitted over driving flats on idler stop.
 - b. Place O-ring (Figure 2) in O-ring groove of mechanical seal seat. Ensure that slot in back face of seal seat (Figure 2) is aligned with pin in seal seat adapter subassembly (25). Press seal seat into seal seat adapter subassembly. Clean seal faces with alcohol and a lint free cloth then apply lubricating oil to running faces of mechanical seal seat (Figure 2) and primary ring (Figure 2). Slide assembled seal seat adapter subassembly (25) on power rotor (7) with seal seat (Figure 2) contacting primary ring (Figure 2).
 - c. Support power rotor (7) and press ball bearing (11) on power rotor (7), pressing only on bearing inner race until bearing just passes truarc ring groove in power rotor. Install truarc ring (15) on seal seat adapter subassembly (25) with drain opening in cover (4). Install gasket (26) into cover (4), then install assembled power rotor in cover (4). DO NOT damage gasket (26) when installing assembled power rotor into cover.
 - d. Install O-ring (31) over cover (4) flange. Mesh each idler (8) with power rotor (7) and slide assembly in pump. Align cover bolt holes with pump bolt holes and install retainer (12) and bolts (6). Tighten bolts (6) to a torque value of 70 lbs.- inch (± 5 lbs.- inch) [8 newton-meters (± 0.5 newton meters)].
- NOTE:** Cover (4) aligned with drain in seal seat adapter subassembly (25), is equipped with a drain port that prevents fluid being pumped from contaminating ball bearing (11) if mechanical seal failure occurs. Install cover (4) on pump so that drain opening will be down when pump is installed.
- e. Rotate power rotor to ensure freedom of rotation.
 - f. Install key (13) and coupling hub on power rotor. Install pump on driver and check alignment as described in Installation, General Operation, Maintenance, and Troubleshooting Manual for Three Screw and CIG Series Pumps (Manual Number SRM00046). Prime pump to expel all air prior to starting.

DISASSEMBLY AND ASSEMBLY OF FIGURE 3, 5, 6 OR 8 PUMPS

Disassemble pump by first completing Removal of Seal and Bearing steps under Servicing Seal and Bearing. Continue to disassemble pump as follows:

- a. Remove bolts (3) and lockwashers (17, steel case only), then remove cover (2). Clean Loctite gasket eliminator from cover (2) and pump flange.
- b. Steel case pumps only (Figure 6, or 7): Remove plug (96) and anti-rotation pin (97). Pull housing (28) from case (1) bore, and then remove O-ring (30) from housing (28).

NOTE: Idler stop is press-fitted on power rotor (7) and should not be removed. Both new power rotor (7) and idler stop are contained as an assembly in a steel case major repair kit and are not sold separately.

Prior to assembly of pump, check each part and remove any burrs by buffing. Wipe all parts with lubricating oil prior to assembly. Rotate power rotor frequently during assembly to ensure freedom of rotation. Assemble pump as follows:

- a. Steel case pumps only (Figure 6 or 7): Slide O-ring (30) in housing (28) O-ring groove. Align anti-rotation hole in housing (28) with case (1) anti-rotation pin hole and slide housing (28) in case (1). Install anti-rotation pin (97) and plug (96).
- b. Iron and Steel case: Wipe all traces of oil from mating flange of cover (2) and pump, then apply a thin coat of Loctite gasket eliminator No. 504 to both cover (2) and pump flange. Install cover (2) on pump using the lockwashers (17, steel case only) and bolts (3). Tighten bolts (3) to a torque value of 70 lbs.-inch (± 5 lbs.-inch) [8 newton-meters (± 0.5 newton-meters)].
- c. Iron and Steel case: Complete assembly of pump following Installation of Seal and Bearing steps under Servicing Seal and Bearing.

DISASSEMBLY AND ASSEMBLY OF FIGURE 7 PUMPS

Prepare pump for disassembly following GENERAL steps, then remove capscrews (27).

NOTE: Capscrews (27) are installed D3EICS pumps. Cover (4) on pump model D3EX is retained by special mounting of pump. Continue disassembly as follows:

- a. Grasp rotor and pull cover (4), O-ring (31), idler (8) and assembled power rotor (7) from housing (1). Remove O-ring (031) from cover (4).

NOTE: DO NOT remove piston (24) and idler stop from power rotor (7). Piston (24), idler stop, and power rotor (7) are received assembled with a steel case major repair kit and parts are not serviced separately.

- b. Remove bolts (3) and lockwashers (17, steel case only) to remove cover (2). Clean Loctite gasket eliminator No. 504 from both cover (2) and pump flange.
- c. Steel case pump only (Figure 7): Remove plug (96) and anti-rotation pin (97). Pull housing (28) from case (1) bore and remove O-ring (30) from housing.

Prior to assembly of pump, check each part and remove any burrs by buffing. Wipe all parts with lubricating oil prior to assembly. Rotate power rotor frequently during assembly to ensure freedom of rotation.

Assemble pump as follows:

- a. Steel case pump only (Figure 7): Slide O-ring (30) in housing (28) O-ring groove. Align anti-rotation hole in housing (28) with case (1) anti-rotation pin hole and slide housing (28) in case (1). Install anti-rotation pin (97) and plug (96).
- b. Iron and Steel Case: Wipe all traces of oil from mating flange of cover (2) and pump, then apply a thin coat of Loctite gasket eliminator No. 504 to both cover and pump flange. Install cover (2) on pump using lockwashers (17, steel case only) and bolts (3). Tighten bolts (3) to a torque value of 70 lbs. inch (± 5 lbs. inch).
- c. Slide O-ring (31) on cover (4) flange. Slide assembled power rotor (parts 7) in cover (4). Mesh idlers (8) with power rotor (7) and slide assembly into pump. On D3EIC and D3EICS pumps, install capscrews (27). Tighten capscrews (27) to a torque value of 45 lbs.-inch (± 5 lbs.-inch) [5 newton-meters (± 0.5 newton-meters)].

NOTE: Capscrews (27) are not installed in D3EX pumps.

- d. Pull power rotor in the axial direction until power rotor contacts cover. Power rotor must remain in the "pulled out" position when the pump is attached to driver.

Table 2 – List of Material for Figures 3 Through 8

| Item | Note* | Part Description | Item | Note* | Part Description |
|--|-------|--|------|-------|-------------------------------|
| 1 | 1 | Housing | 17 | 5 | Lockwasher (4) |
| 2 | | Cover | 24 | 3, 6 | Piston |
| 3 | | Bolt 1/4 x 3/4" (4) | 25 | 7 | Seal Seat Adaptor Subassembly |
| 4 | | Cover | 26 | 4 | Gasket .015" |
| 6 | 2 | Bolt 1/4 x 2/5" (4) | 27 | 8 | Capscrew (4) |
| 7 | 3, 10 | Power Rotor | 28 | 5 | Housing |
| 8 | | Idler (2) | 30 | 5 | O-ring |
| 11 | 4 | Ball Bearing | 31 | | O-ring |
| 12 | 4 | Retainer | 32 | 9 | Seat Adaptor |
| 13 | | Key | 33 | 9 | Spring Pin |
| 15 | 4 | Truarc Ring | 96 | 5 | Plug |
| 16 | 4 | Mechanical Seal | 97 | 5 | Anti-Rotation Pin |
| Note*: | 1 | Steel case pump part description is Case. | | | |
| | 2 | All pumps except D3EIC, D3EICS and D3EX. | | | |
| | 3 | Parts 7, 9 and 24 Factory Assembled for D3EICS Major Repair Kit. | | | |
| | 4 | Mechanical Seal and Ball Bearing type pumps only. | | | |
| | 5 | Steel case pump only. | | | |
| | 6 | D3EIC, D3EICS and D3EX type pumps only. | | | |
| | 7 | Includes part 32 and 33. | | | |
| | 8 | D3EIC and D3EICS type pump only. | | | |
| | 9 | Part of Item 25. | | | |
| | 10. | Parts 7 and 9 Factory Assembled for D3EB Major Repair Kit. | | | |
| ALL QUANTITIES ARE ONE (1) EXCEPT WHEN NOTED IN PARENTHESES AFTER PART DESCRIPTION. | | | | | |

REPAIR KITS

Minor Repair Kits are available for pumps equipped with mechanical seal and ball bearing. Major Repair Kits are available for all steel case pumps. Major Repair Kits are not available for iron case pumps because major repairs are not considered economical. If extensive repair is required to an iron case pump, the pump should be discarded and a new pump purchased. Repair parts are available only in kit form.

Table 3 – Repair Kit Parts

| PUMP MODEL | PART NO. | | | | | | | | | | | | |
|--|----------|---|---|---|---|----|----|----|----|----|----|----|----|
| | 2 | 4 | 7 | 8 | 9 | 11 | 15 | 16 | 24 | 26 | 28 | 30 | 31 |
| D3EBC | | | | | | 1 | 1 | | | 1 | | | 1 |
| D3EBF | | | | | | 1 | 1 | | | 1 | | | 1 |
| D3EBCS | 3 | | 3 | 3 | 3 | 2 | 2 | | | 2 | 3 | 2 | 2 |
| D3EBTCS | 3 | | 3 | 3 | 3 | 2 | 2 | | | 2 | 3 | 2 | 2 |
| D3EBFS | 3 | | 3 | 3 | 3 | 2 | 2 | | | 2 | 3 | 2 | 2 |
| D3EBTFS | 3 | | 3 | 3 | 3 | 2 | 2 | | | 2 | 3 | 2 | 2 |
| D3EXCS | 3 | | 3 | 3 | 3 | 2 | 2 | | | 2 | 3 | 2 | 2 |
| D3EICS | 3 | 3 | 3 | 3 | 3 | | | 3 | | | 3 | 3 | 3 |
| (1) Minor Repair Kit Part Only (2) Major Repair Kit Part (includes all Minor Repair Kit Parts) (3) Major Repair Kit Only | | | | | | | | | | | | | |

ORDERING INSTRUCTIONS

All correspondence pertaining to renewal parts for the equipment must refer to the instruction manual number and should be addressed to the nearest Imo representative. The handling of renewal orders will be greatly facilitated if the following directions are carefully observed:

1. Give the number of the instruction manual with revision level and date.
2. Give the serial number of the pump for which the part is desired. This number appears on the nameplate.
3. Identify the kit (Minor or Major) required.

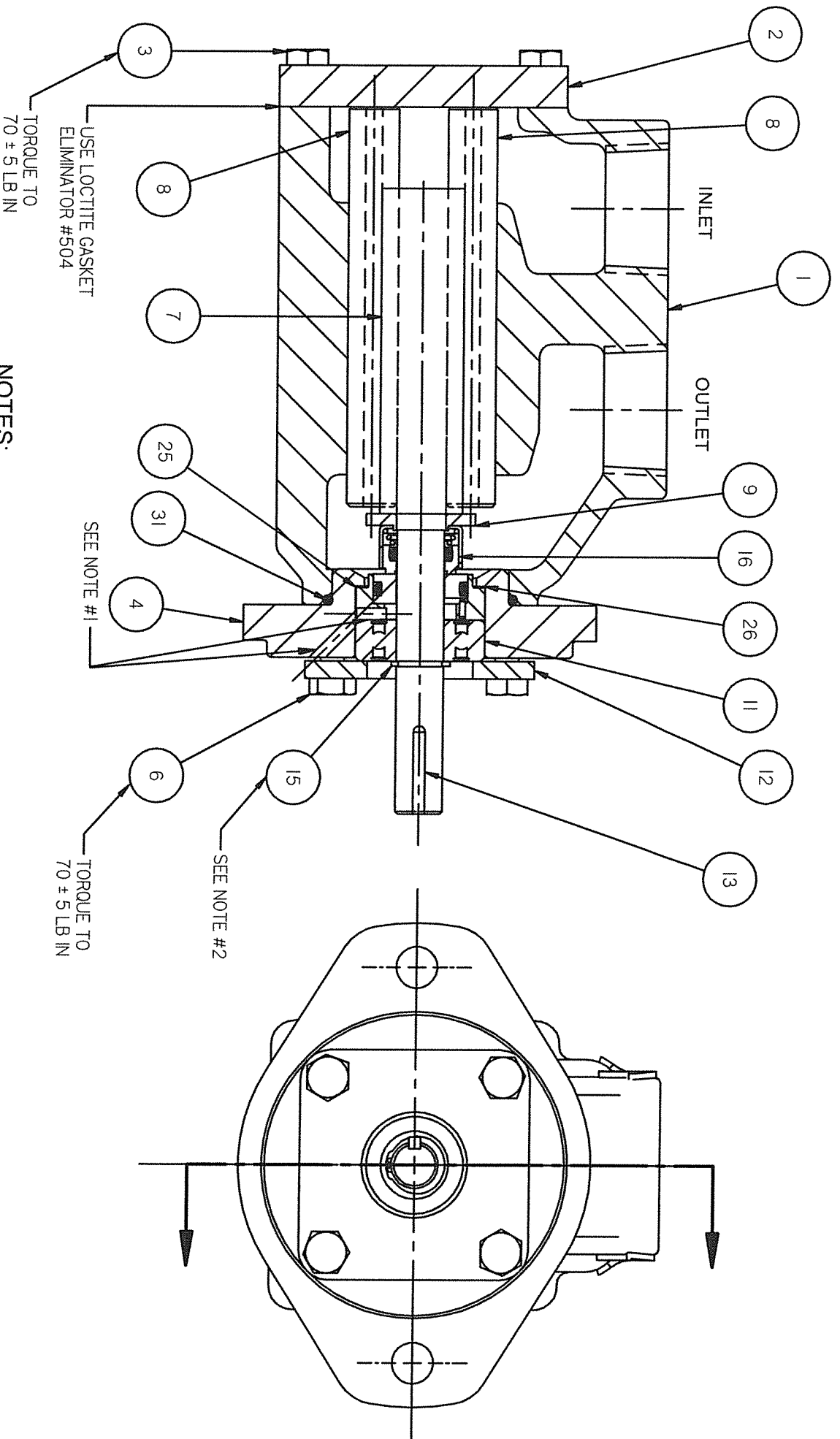

- NOTES:
1. DRAIN HOLES IN P/N 4 & 25 ARE TO BE ASSEMBLED IN DOWN POSITION WHEN PUMP IS INSTALLED.
 2. SNAP RING TO BE ASSEMBLED WITH SHARP EDGE ON ITS ID FACING TOWARD COUPLING END OF SHAFT. CARE MUST BE TAKEN NOT TO OVERSTRETCH SNAP RING ON ASSEMBLY.

FIGURE 3 IRON CASE C-FACE ASSEMBLY

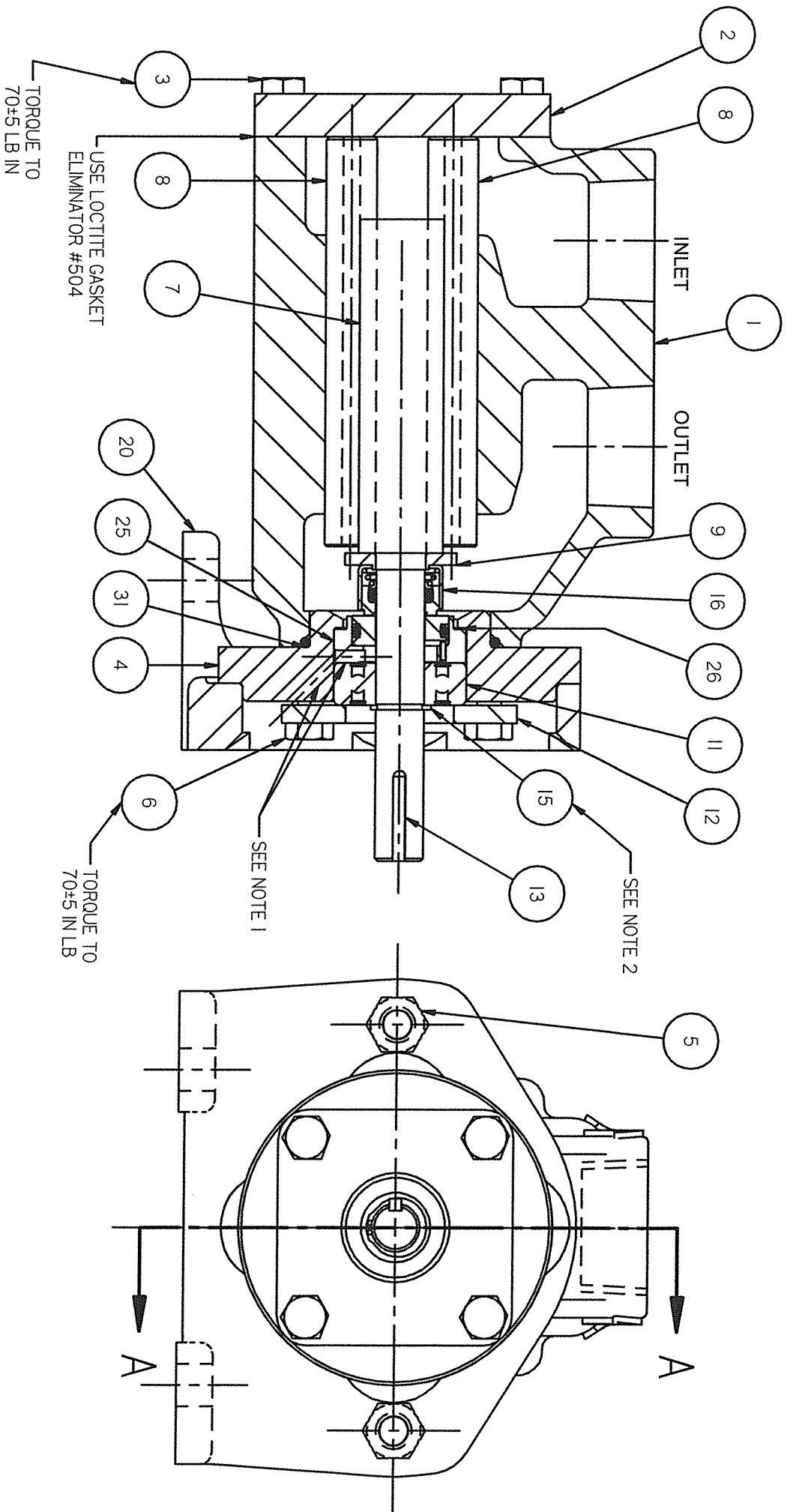
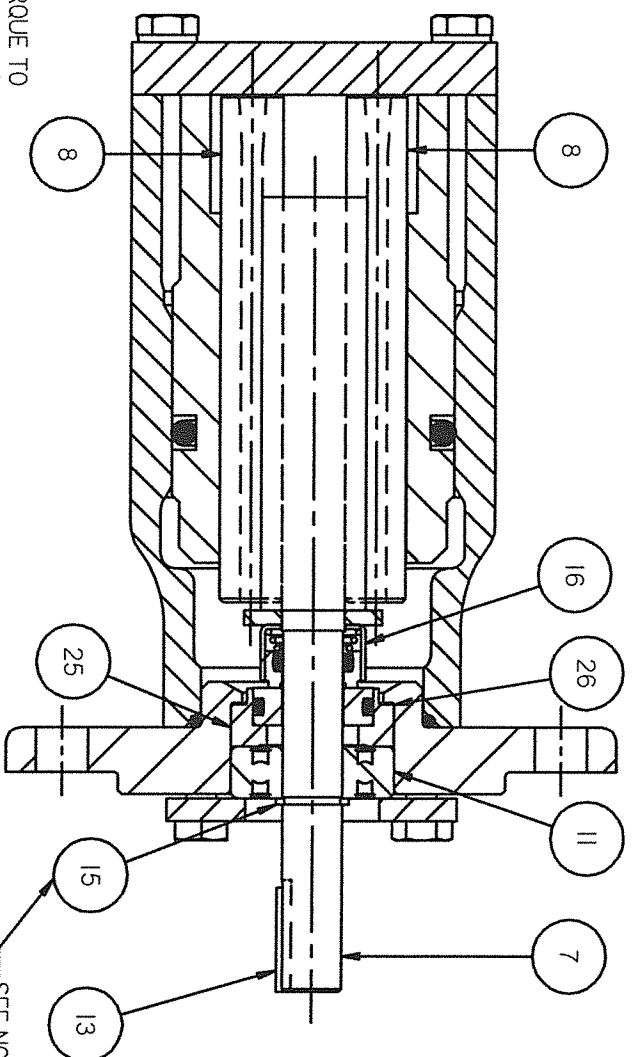

FIGURE 5 IRON CASE FOOT MOUNT ASSEMBLY



TORQUE TO
70 ± 5 LB IN

SEE NOTE #2

- NOTES:
1. DRAIN HOLES IN P/N 4 & 25 ARE TO BE ASSEMBLED IN DOWN POSITION WHEN PUMP IS INSTALLED.
 2. SNAP RING TO BE ASSEMBLED WITH SHARP EDGE ON ITS ID FACING TOWARD COUPLING END OF SHAFT. CARE MUST BE TAKEN NOT TO OVERSTRETCH SNAP RING ON ASSEMBLY.

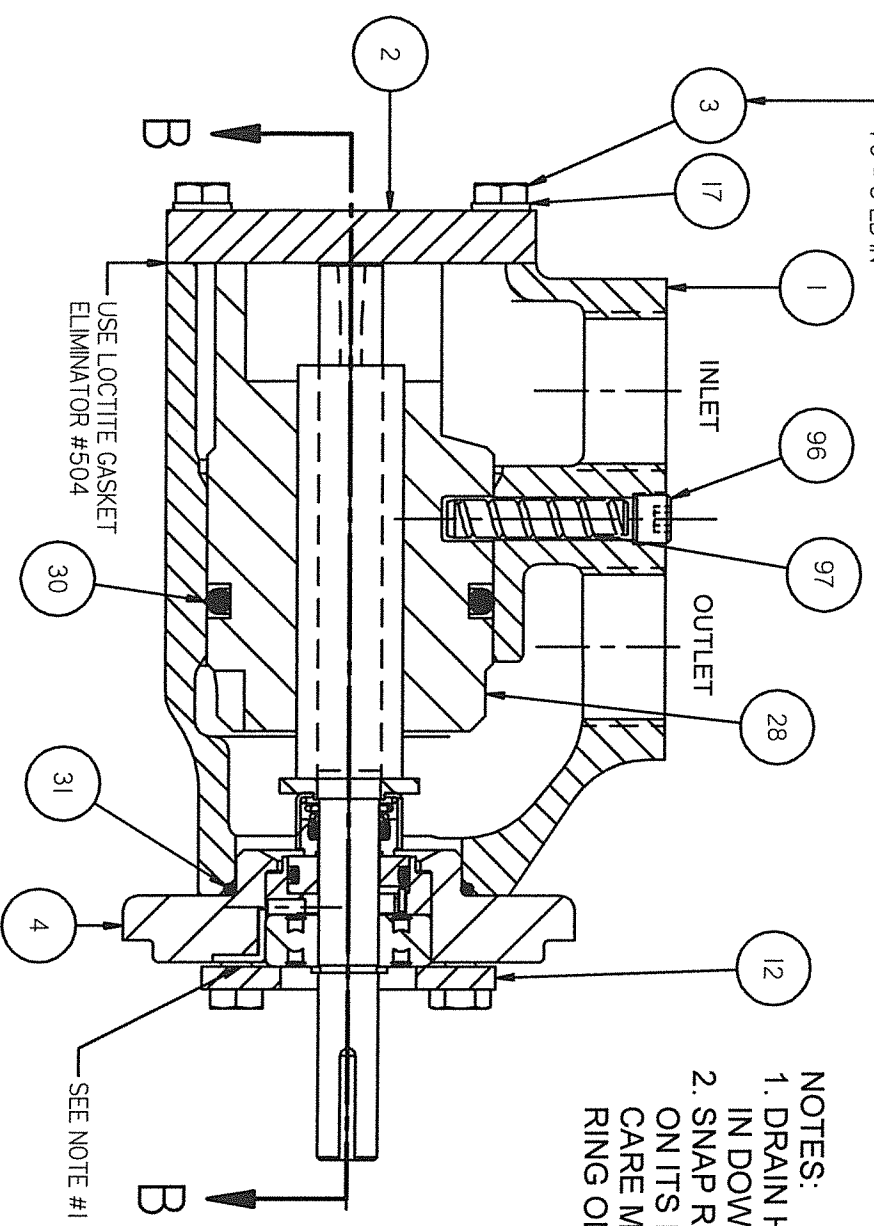

USE LOCTITE GASKET
ELIMINATOR #504

SEE NOTE #1

FIGURE 6
STEEL CASE C-FACE
ASSEMBLY

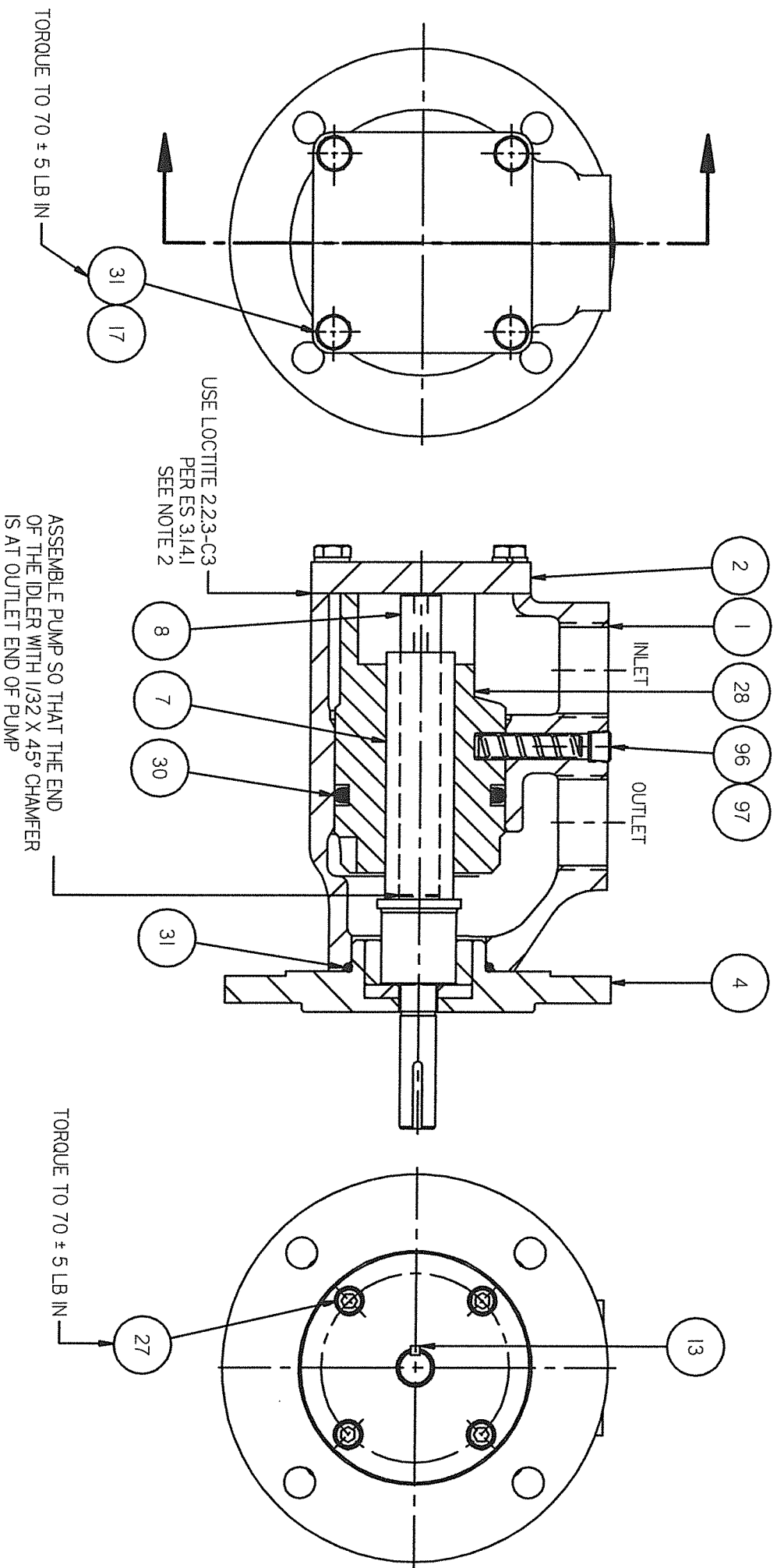
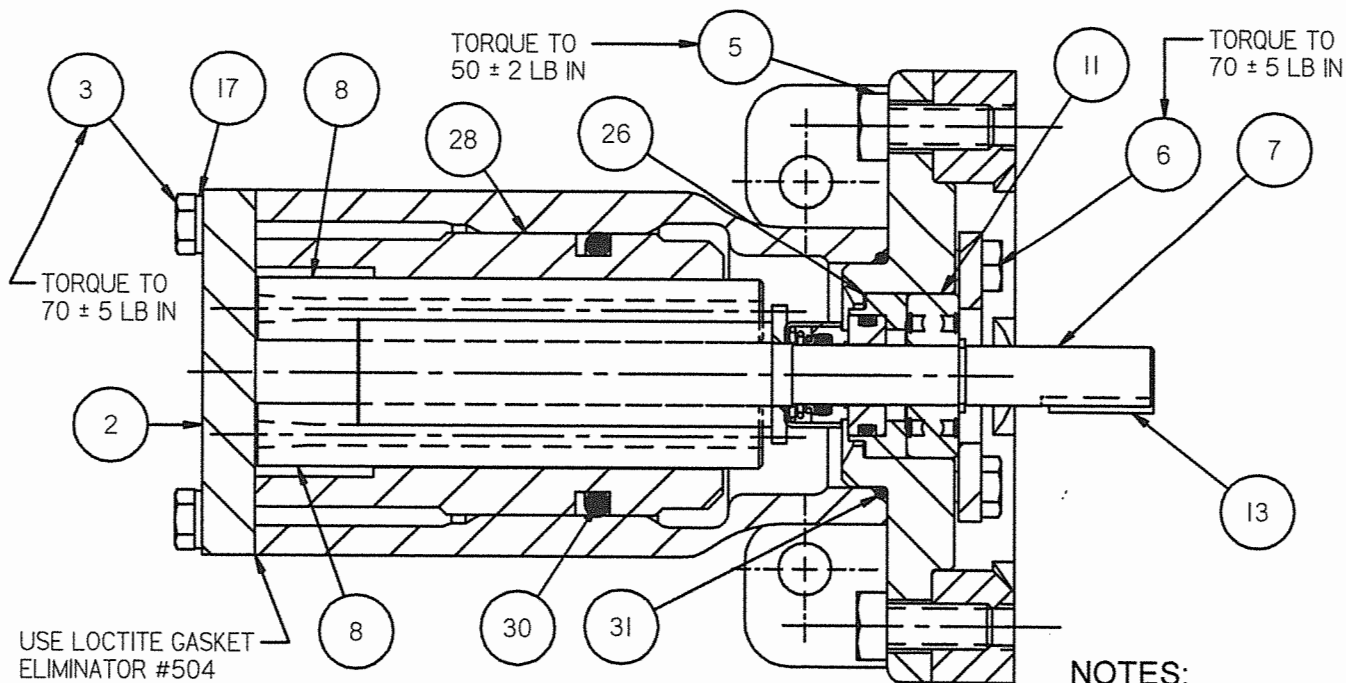
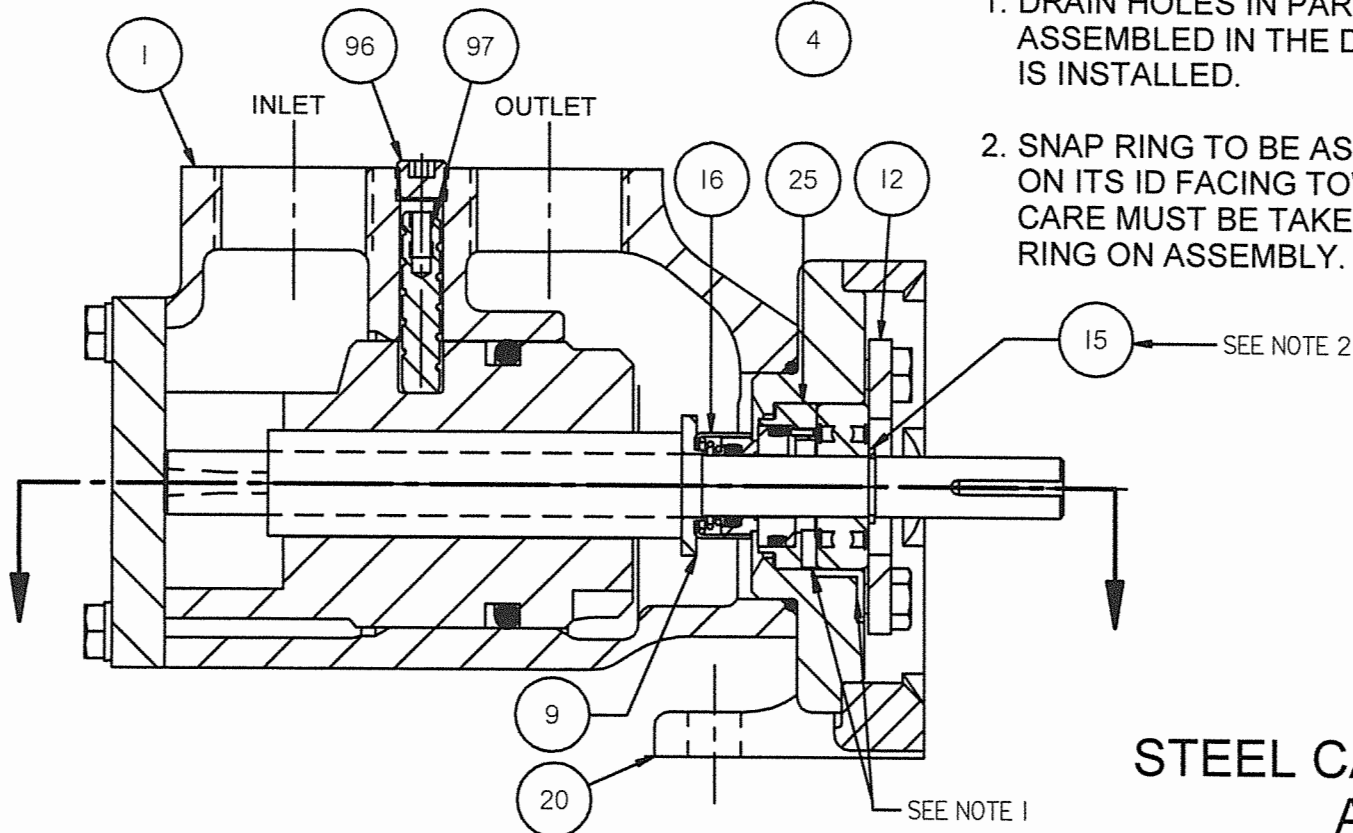

FIGURE 7 - STEEL CASE EIC C-FACE ASSEMBLY



NOTES:

1. DRAIN HOLES IN PART NO. 4 & NO.25 ARE TO BE ASSEMBLED IN THE DOWN POSITION WHEN PUMP IS INSTALLED.
2. SNAP RING TO BE ASSEMBLED WITH SHARP EDGE ON ITS ID FACING TOWARD COUPLING END OF SHAFT. CARE MUST BE TAKEN NOT TO OVERSTRETCH SNAP RING ON ASSEMBLY.



**FIGURE 8
STEEL CASE FOOT MOUNT
ASSEMBLY**

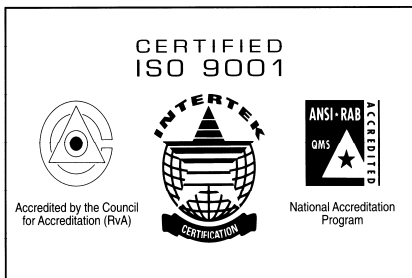

CIRCOR
1710 Airport Road
PO Box 5020
Monroe, NC USA
28111.5020

Tel: +1.877.853.7867
Email: cc@circor.com
Web: circorpt.com

