



INSTRUCTION MANUAL

**Pump Type A12LB
DISASSEMBLY AND ASSEMBLY PROCEDURES
FOR
INSTALLATION OF MINOR AND MAJOR REPAIR KITS**

WARNING

**READ CA-1 AND THIS INSTRUCTION BOOK BEFORE
INSTALLATION, OPERATION OR MAINTENANCE**

Instructions A12LB (R-1)

This manual now is
identified as part no.
SRM00036

**Imo Delaval Inc.
IMO Pump Division
P.O. Box 447
Airport Road
Monroe, NC 28111-0527
USA**

Jun 1987

FOREWORD

Series 12LB pumps have been obsoleted and replaced by Series E12L models. Minor and Major Repair Kits are available for the following obsoleted 12LB pumps:

A12LBS-118, 137, 156, 187 and 200
A12LBST-118, 137, 156, 187 and 200

In order to utilize these Repair Kits, new idler rotor sets consisting of parts (033, 067 and 075) and a new thrust plate (038) must be installed.

DISASSEMBLY OF PUMP

1. Close suction and discharge piping to pump. Disconnect piping and uncouple pump from driver. Remove key (027).
2. Remove capscrews (040) and Dyna seal (041) from outboard end cover (036). Ensure there is a container under pump to catch oil, then pull outboard end cover (036) away from bottom of inlet head (021) enough to allow oil to drain. Rotate power rotor in opposite direction of normal rotation to drain oil trapped in rotors.
3. Remove outboard end cover (036) with O-rings (014 and 019) and thrust plate (038). Remove O-ring (014) from groove of end cover (036). Remove capscrews (043) with washers (042) and remove thrust plate (038) from end cover (036). Remove O-ring (019) from grooves of end cover (036).
4. Remove capscrews (039) and inlet head (021). Remove O-rings (013 and 019) from grooves in pump case (001). Remove spacer or shim (005) from pump case (001). NOTE: For rotor sizes 137 and 187, remove spacer (065) from pump case (001).
5. Remove idler rotors (033) from bores of rotor housing (003). Rotate power rotor (023) in opposite direction of normal rotation to remove remaining idler rotors from housings. Do Not allow idler rotors to drop as they emerge from outboard end of pump case (001).
6. Remove bolts (030) and bearing retainer (029) from inboard cover (012).
7. Remove assembled power rotor (023) from inboard end of pump. Removal of power rotor (023) will also remove locknut (031), lockwasher (032), ball bearing (028), retaining ring (025), bearing spacer (026, 062 or 073) and mechanical seal (024). Remove locknut (031) and lockwasher (032). Remove ball bearing (028) and retaining ring (025). Remove bearing spacer (026, 062 or 073). Remove mechanical seal (024) stationary seat and slide mechanical seal (024) rotating assembly (3, Figure 1, 2 or 3) from power rotor shaft. NOTE: For pump type A12LBST, mechanical seal (024) stationary seat will be removed with bearing spacer (026, 062 or 073). Remove stationary seat (1, Figure 2) from spacer (026, 062 or 073) and remove O-ring (2, Figure 2) from seal seat (1, Figure 2). Figure 3 requires loosening of setscrews (3F, Figure 3) prior to removal of rotating assembly from power rotor (023).
8. Remove gasket from mechanical seal bore of inboard end cover (012).
9. Remove capscrews (018) and assembled inboard end cover (012) with O-ring (007), back-up ring (006), bushing (015), idler stop (017) and truarc ring or capscrews (066). Remove O-ring (007) and back-up ring (006) from inboard end cover (012). Remove truarc ring (066), idler stop (017) and bushing (015) from inboard cover (012). NOTE: For rotor sizes 187 and 200, remove capscrews (066) to remove idler stop (017) and bushing (015) from inboard end cover (012).

10. Remove O-rings (019) from grooves of inboard end of case (001).
11. Remove O-ring plug (011) and O-ring (010). Remove rotor housing stop pin (009).
12. Remove rotor housings (003 and 004) from inboard end of pump case (001). Do Not permit housings (003 and 004) to drop as they are removed from pump case.
13. Separate housings (003 and 004) and remove dowel pins (008). Remove O-ring (007) and back-up ring (006) from groove of housing (004). If applicable to pump type, remove spacer (016) from pump case (001).

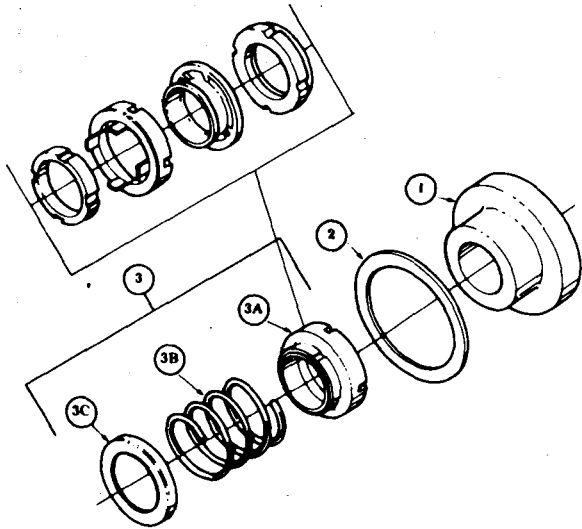

1. SEAT
2. GASKET
3. ROTATING ASSEMBLY
- 3A. WASHER BELLOWS ASSEMBLY
- 3B. SPRING
- 3C. SPRING HOLDER

FIGURE 1. Crane 21 w/Clamped Seal

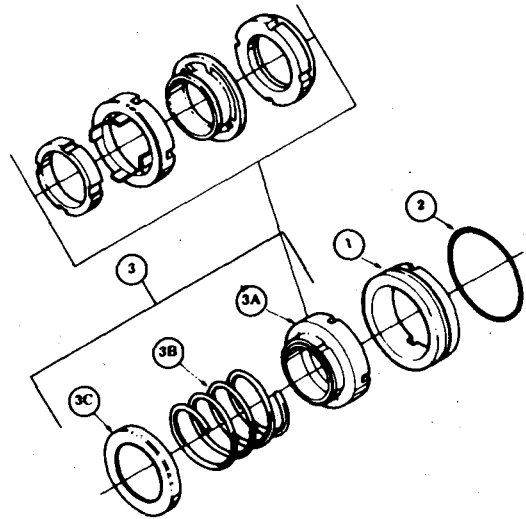

1. SEAT
2. O-RING
3. ROTATING ASSEMBLY
- 3A. WASHER BELLOWS ASSEMBLY
- 3B. SPRING
- 3C. SPRING HOLDER

FIGURE 2. Crane 21 w/O-ring Seat

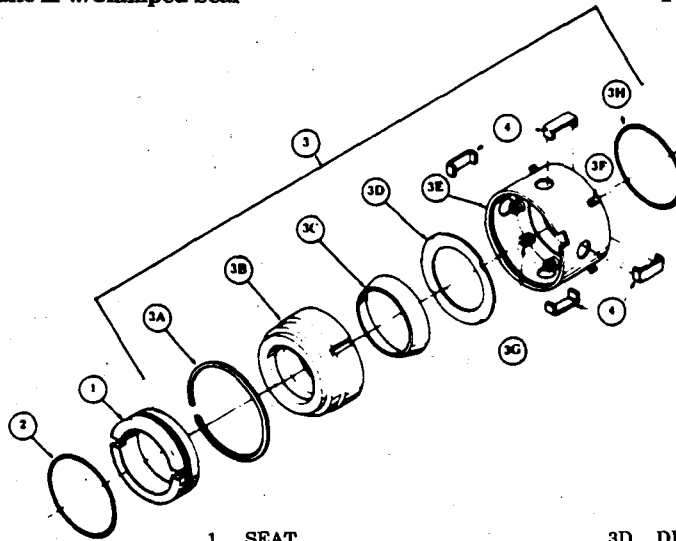

- | | |
|----------------------|--------------------|
| 1. SEAT | 3D. DISC |
| 2. O-RING | 3E. RETAINER |
| 3. ROTATING ASSEMBLY | 3F. SETSCREW |
| 3A. SNAP RING | 3G. SPRING |
| 3B. WASHER | 3H. O-RING(S) |
| 3C. CHEMLON RING | 4. RETAINING CLIPS |

FIGURE 3. Crane 9B3 w/Clamped Seat

ASSEMBLY OF PUMP

NOTE: Inspect and clean all parts prior to assembly. The IMO Pump division recommends automatic replacement of all gaskets, O-rings, mechanical seals and bearings when these parts are disturbed from their previous installed position. All parts, including bolts and nuts, should be wiped with lubricating oil prior to assembly to aid in pump assembly. Do Not use grease.

1. Install O-ring (007) in groove of rotor housing (004). Install back-up ring (006) in groove of housing (004) so that back-up ring (006) will be positioned toward the inboard end of pump when housing is installed.
2. Install rotor housing (003) into pump case (001) from inboard end of case with dowel pins (008) installed in housing (003). Push housing (003) into case just beyond end of case. Install rotor housing (004) into inboard end of case, ensuring that dowel pins installed in housing (003) are aligned with mating bores in housing (004). Push both housings into case (001) until stop pin (009) slot in housing (004) is aligned with stop pin bore in case (001). Use caution to avoid damage to O-ring (007) during installation of housing (004).
3. Install rotor housing stop pin (009), ensuring that it is properly seated in slot. Install O-ring (010) and plug (011).
4. Refer to applicable pump assembly drawing for pump type and install required spacer(s). Install spacer (016) into inboard end of pump case (001). Install spacer (065) into outboard end of case (001).
5. Install O-ring (007) and back-up ring (006) into groove of inboard end cover (012). Back-up ring should be positioned toward inboard end of pump when cover is installed on case (001). Install bushing (015) and idler stop (017) into inboard end cover (012). Based on applicable pump model, install retaining ring (066) or capscrews (066) to hold idler stop (017) in position. Install O-rings (019) in grooves of inboard end of case (001). Apply a light coat of oil to locating diameter of inboard end cover (012) and install cover (012) on case (001) with discharge bore aligned with discharge opening of case (001). Install capscrews (018) and torque capscrews (018) to 100 lbs. ft. (± 10 lbs. ft.) for rotor size 118, 160 lbs. ft. (± 10 lbs. ft.) for rotor sizes 137 and 156, or 290 lbs. ft. (± 10 lbs. ft.) for rotor sizes 187 and 200.
6. Slide mechanical seal (024) rotating assembly (3, Figure 1, 2 or 3) on power rotor (023) shaft next to step-cut shoulder of shaft.
7. Install mechanical seal (024) stationary seat (1, Figures 1 and 3) on power rotor (023) shaft.
NOTE: For pump type A12LBST, install O-ring (2, Figure 2) on mechanical seal seat (1, Figure 2). Install assembled seat (1 and 2, Figure 2) in bearing spacer (026, 062 or 073), ensuring that spring pin engages slot in seal seat.
8. Install bearing spacer (026, 062 or 073) on power rotor (023) shaft. Install retaining ring (025) in groove of power rotor shaft. Press ball bearing (028) on power rotor shaft, pressing only on inner race of bearing. Install lockwasher (032) and locknut (031) on power rotor shaft.
9. Install gasket into counter bore of inboard end cover (012).
10. Install assembled power rotor (023) into pump, centering each part as it enters inboard end cover (012). Install bearing retainer (029) using bolts (030). Torque bolts (030) to a torque value of 25 lbs. ft. (± 2 lbs. ft.).
11. Install two new idler rotors (033) into bores of housing (003) at inlet end of pump. Mesh threads of idler rotors (033) with threads of power rotor (023) and rotate power rotor in direction of normal rotation to draw idler rotors into pump. Install four new idler rotors (075) and two new idler rotors (067) in the same manner as described above until all eight segments of idler rotors are installed.

12. Push housings (003 and 004) tightly against inboard end of pump. Measure distance from outboard flange of pump case (001) to housing (003) or, if applicable to pump type, spacer (065) to determine correct thickness of shim or spacer (005). Remove or add layers of laminated shim (005) or machine spacer (005) to measurement determined above and to allow a clearance of .005-inch to .015-inch. Install laminated shim or spacer (005) in pump case (001).
13. Install O-rings (013 and 019) into grooves of outboard end of case (001). Install inlet head (021) using capscrews (039). Torque capscrews (039) to a torque value of 100 lbs. ft. (± 10 lbs. ft.) for rotor size 118, 160 lbs. ft. (± 10 lbs. ft.) for rotor sizes 137 and 156, or 290 lbs. ft. (± 10 lbs. ft.) for rotor size 187 and 200.
14. Install O-rings (019) in grooves of outboard end cover (036). Install new thrust plate (038) on end cover (036) using capscrews (043) with washers (042). Install O-ring (014) in groove of end cover (036). Install assembled outboard end cover (036) on inlet head (021) using capscrews (040) with Dyna seal (041). Torque capscrews (040) to a torque value of 50 lbs. ft. (± 5 lbs. ft.). NOTE: Ensure that thrust plate (038) is properly positioned so that oil holes are properly aligned with idler rotors.

NOTE: Inlet head may be rotated in 90 degree increments, however, care must be taken to ensure that position of outboard end cover (036) and thrust plate (038) remains the same.

LIST OF MATERIAL

ITEM	DESCRIPTION	ITEM	DESCRIPTION
001	Pump Case	029	Bearing Retainer
002	Eyebolt (2)	030	Bolt
003 XX	Rotor Housing	031 XX	Lock Nut
004 XX	Rotor Housing	032 XX	Lockwasher
005 XX	Laminated Shim or Spacer	033 XX	Idler Rotor (2)
006 X	Back-up Ring (2)	036	Outboard End Cover
007 X	O-ring (2)	037	Pipe Plug
008	Dowel Pin (2)	038 XX	Thrust Plate
009	Stop Pin	039	Capscrew (8)
010 X	O-ring	040	Capscrew (8)
011	Plug	041 X	Dyna Seal (8)
012	Inboard End Cover	042	Washer (4)
013 X	O-ring	043	Capscrew (4)
014 X	O-ring	044 thru 047	Inlet Adapter Assembly
015 XX	Balance Piston Bushing	048 thru 051	Outlet Adapter Assembly
016 (1)	Spacer	052	Nameplate
017 XX	Idler Stop	055	Nameplate
018	Capscrews (8)	056	Rivet (6)
019 X	O-ring (5)	064 (4)	Bearing Spacer
020	Pipe Plug (5)	065 (2)	Spacer
021	Inlet Head	066 XX	Truarc Ring
022	Pipe Plug	066 XX (3)	Capscrew (2)
023 XX	Power Rotor	067 XX	Idler Rotor (2)
024 X	Mechanical Seal	070 X (6)	Gasket
025 X	Truarc Ring	073 (5)	Bearing Spacer Subassembly
026 XX	Bearing Spacer	074 X	Loctite Sealant
027	Key	075 XX	Idler Rotor (4)
028 X	Ball Bearing		

Quantities are one (1) except when noted in parentheses after part description.

X denotes Minor Repair Kit items.

XX denote Major Repair Kit items. Items marked X also included in Major Repair Kit.

- (1) Rotor sizes 137, 156, 187 and 200 only.
- (2) Rotor sizes 137 and 187 only.
- (3) Rotor sizes 187 and 200 only.
- (4) A12LBST, rotor size 118 only.
- (5) A12LBST, rotor size 137 only.
- (6) A12LBST, rotor sizes 118, 187 and 200 only.

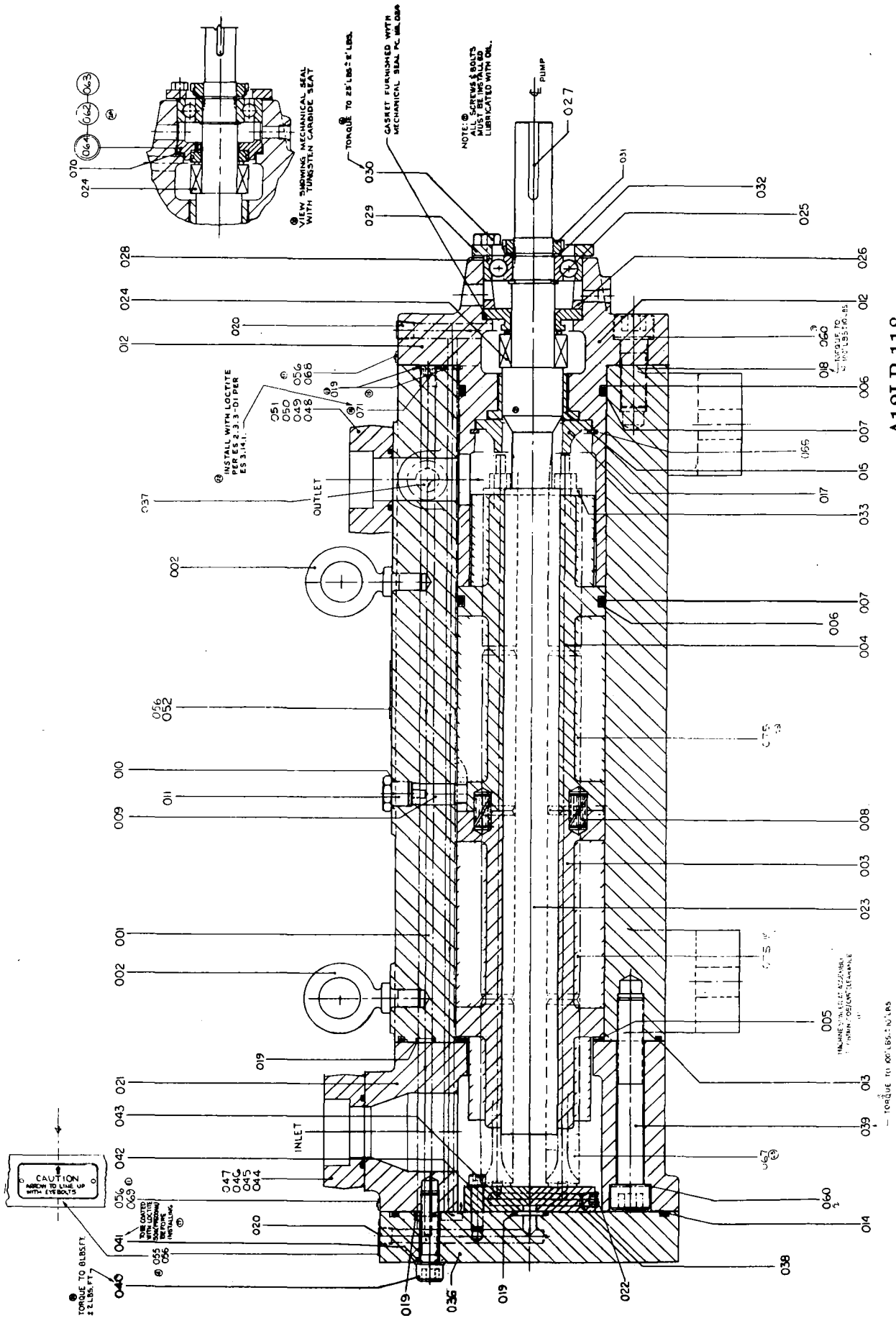

A12LB-118

A12LBST-118

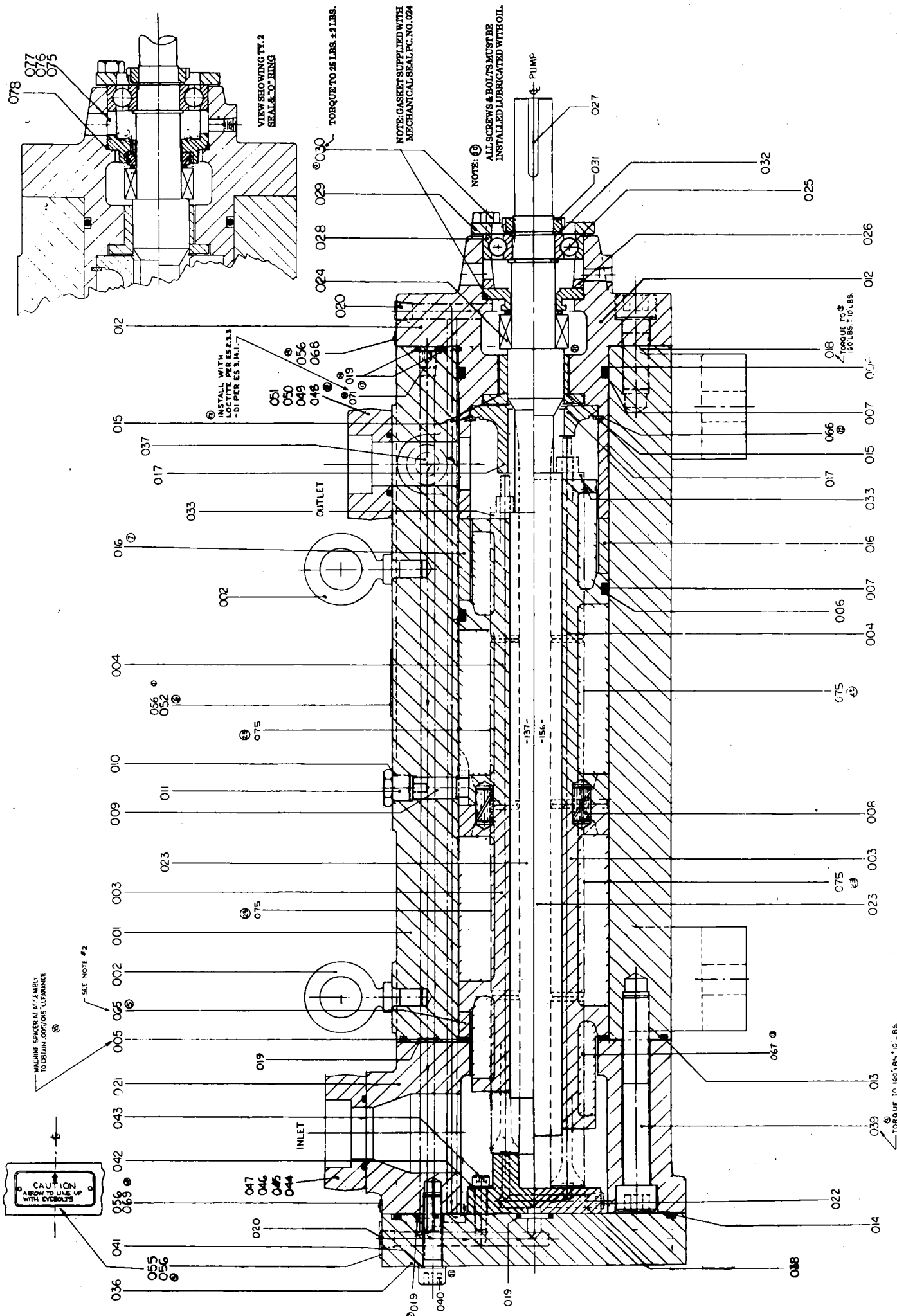

A12LBST-137/156

A12LB-137/156

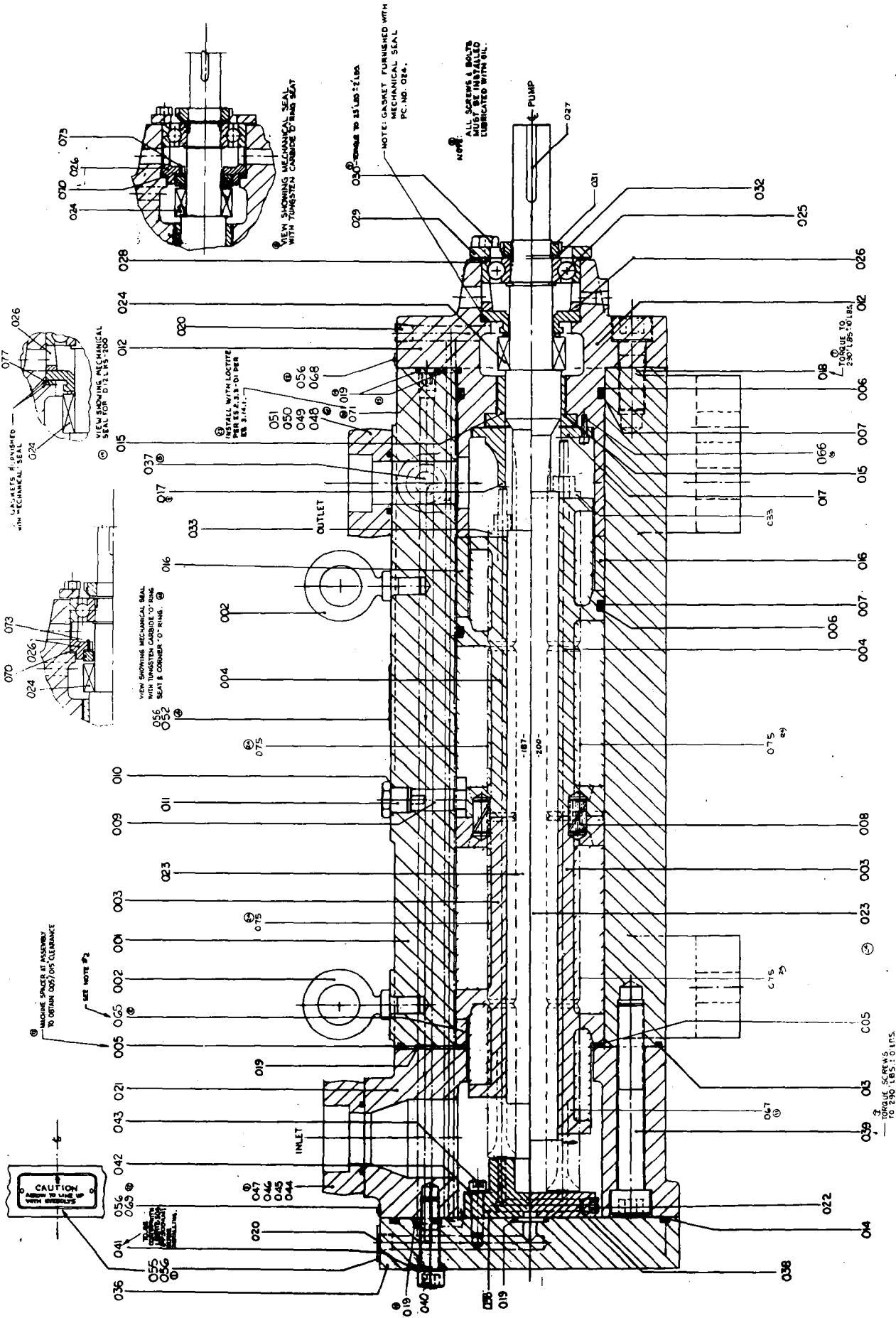

A12LBST-187/200

A12LB-187/200

TO OIL SCREWS
TO 230, 165, 0115.