



**INSTRUCTION MANUAL  
AND  
PARTS LIST  
FOR  
3E CANNED MOTOR PUMPS**



**WARNING**

This Special Instruction Manual and General Instructions Manual, CA-1, should be read thoroughly prior to pump installation, operation or maintenance.

**SRM00072 | Rev. 0 (02-0037) | January 28, 2002**



## READ THIS ENTIRE PAGE BEFORE PROCEEDING

FOR THE SAFETY OF PERSONNEL AND TO PREVENT DAMAGE TO THE EQUIPMENT, THE FOLLOWING NOMENCLATURE HAS BEEN USED IN THIS MANUAL:

	<b>DANGER</b>	
Failure to observe the precautions noted in this box can result in severe bodily injury or loss of life.		

	<b>WARNING</b>	
Failure to observe the precautions noted in this box can cause injury to personnel by accidental contact with the equipment or liquids. Protection should be provided by the user to prevent accidental contact.		

	<b>CAUTION</b>		<b>ATTENTION</b>
Failure to observe the precautions noted in this box can cause damage or failure of the equipment.			

Non compliance of safety instructions identified by the following symbol could affect safety for persons:  	Safety instructions where electrical safety is involved are identified by:  	Safety instructions which shall be considered for reasons of safe operation of the pump and/or protection of the pump itself are marked by the sign:  <div style="text-align: center;"><b>ATTENTION</b></div>
--	---	---

### CONTENTS

Safety and Table of Contents .....	A
General Instructions .....	1
Ordering Instructions.....	1
Model Designation .....	1
Installation .....	2
Operation .....	3
Inspection and Parts List.....	3
Maintenance - Disassembly Instructions.....	3 - 4
Maintenance - Reassembly Instructions .....	4
Pump Assembly Drawings .....	6 - 7

<b>ATTENTION</b>
<b><i>If operation of this pump is critical to your business, we strongly recommend you keep a spare pump or major repair kit in stock at all times. As a minimum, a minor repair kit (o-rings, gaskets, shaft seal and bearings) should be kept in stock so pump refurbishment after internal inspection can be accomplished.</i></b>

## GENERAL INSTRUCTIONS

**NOTE:** Individual contracts may have specific provisions that vary from this manual. Should any questions arise which may not be answered by these instructions, refer to General Instructions Manual, CA-1, provided with your order. For further detailed information and technical assistance please refer to Imo Pump, Technical Service Department at (704) 289-6511.

This manual cannot possibly cover every situation connected with installation, operation, inspection and maintenance of equipment supplied. Every effort was made to prepare text of manual so that engineering and design data is transformed into most easily understood wording. Imo Pump must assume personnel assigned to operate and maintain supplied equipment and apply this instruction manual have sufficient technical knowledge and are experienced to apply sound safety and operational practices which may not be otherwise covered by this manual.

In applications where equipment furnished by Imo Pump is to be integrated with a process or other machinery, these instructions should be thoroughly reviewed to determine proper integration of the equipment into overall plant operational procedures.

This manual covers 3E Canned Motor Pumps. Model numbers of a particular pump may be found on nameplate. Refer to Figures 1, 4 & 5 and Tables 1& 2 for instructional keys when using this manual.

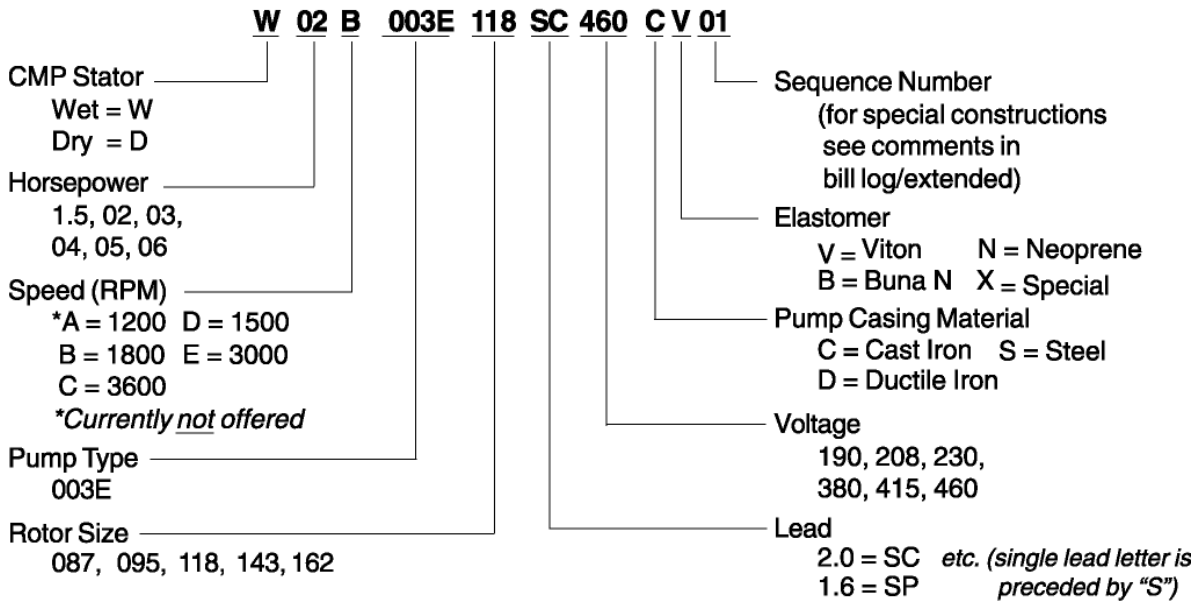

**Figure 1 – Model Designation**

IMO

CANNED MOTOR PUMP

Imo Pump Monroe NC USA

---

Imo Pump

TYPE <input style="width: 80px;" type="text"/>	DATE <input style="width: 80px;" type="text"/>	
SERIAL <input style="width: 100px;" type="text"/>	TIME RATING <input style="width: 80px;" type="text"/>	
HP <input style="width: 40px;" type="text"/>	RPM <input style="width: 40px;" type="text"/>	CODE <input style="width: 40px;" type="text"/>
VOLTS <input style="width: 40px;" type="text"/>	HERTZ <input style="width: 40px;" type="text"/>	PH <input style="width: 40px;" type="text"/>
INSUL CLASS <input style="width: 40px;" type="text"/>	AMPS <input style="width: 40px;" type="text"/>	AMB <input style="width: 40px;" type="text"/> *C

**Figure 2 – Nameplate Data**

### Ordering Instructions

All correspondence pertaining to renewal parts for equipment must refer to instruction book and should be addressed to the nearest Imo Pump representative or sales office.

Handling of renewal orders will be greatly facilitated if following directions are carefully observed:

1. Give number of instruction book.
2. Give serial number of machine for which part is desired. Number appears on nameplate
3. Give name and part number from parts list or assembly drawing

## INSTALLATION



### WARNING

This Equipment is limited to handling fluids compatible with motor windings and insulation. Provide suitable safety and emergency systems to protect personnel and property from injury due to pump malfunction, If pump handles hazardous fluids, provide for safety in event of pump leakage or malfunction.

### CAUTION

### ATTENTION

Piping to pump MUST be independently supported and not allowed to impose strains on case. Piping connections should be flexible whenever possible and make provision for expansion and contraction due to temperature change. Piping connections must not impose more than 1 times "API" forces and moments on inlet and outlet.

### Suction Line

The suction line should be as short as possible. A suction line one size larger than pump inlet is recommended. All joints in suction line must be tight and sealed. This prevents air from being drawn into a pump with negative suction pressure or leaks from pump or line with positive pressure.

### Suction Strainer

A suction strainer of at least 100 mesh with a flow capacity of 30 - 50 gpm and a pressure drop not exceeding 0.5 psi ( when newly installed) should be used. (Inlet strainer shall be sized to insure that pressure at inlet port of pump will not, under any circumstances, exceed 10 inches of mercury vacuum.) Maintenance instructions shall provide for periodic cleaning or replacement of inlet strainer.

### Electrical Connections

A label giving the electrical wiring connections for canned motor pump is located under conduit box cover and in Figure 3. Note that extended reverse rotation can cause pump damage.

3 Phase-Single Voltage

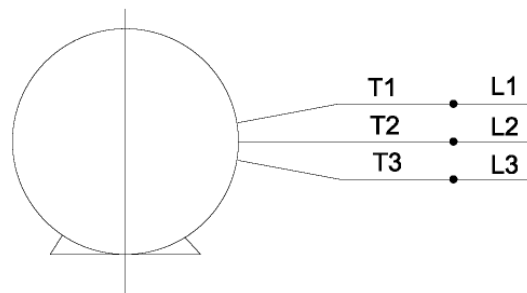

To reverse direction of rotation, interchange any two leads

Figure 3 – Motor Wiring Connections

### Rotation

Before attempting to operate pump, rotation must be verified. It is suggested that this can best be accomplished with a Phase and Motor Rotation Tester such as AVO Biddle Instruments Catalogue No. 560060 / 560400 (510 Township Line Road, Blue Bell, PA 19422 USA). Follow instrument manufacture's instructions to determine proper motor/pump rotation.

## OPERATION

### Structural Limits

Operating conditions, such as speed, fluid viscosity, inlet pressure, discharge pressure, temperature, filtration, duty cycle, mounting etc. are interrelated. Due to these variable conditions, specific application limitation may be different from structural limitations. This equipment must not be operated without verification that operating requirements are within its capabilities.

<b>CAUTION</b>	<b>ATTENTION</b>	
Under no circumstances are the following structural limitations to be exceeded:		
Maximum Inlet Pressure .....		50 PSIG
Maximum Discharge Pressure .....		150 PSIG
Maximum Fluid Temperature.....		240°F

### INSPECTION AND PARTS LIST

Intervals for inspection and replacement of wear parts will vary greatly with the properties of pumped fluid and can only be determined by experience. All internal parts of unit are lubricated and cooled by pumped fluid. Fluid that contains abrasive materials or is corrosive will significantly reduce service life and require shorter service intervals. Wear in pump will normally show as vibration, noise, and loss of capacity or reduction in flow or pressure.

**Table 1 – Pump Parts List**

IDP	DESCRIPTION	QTY
118	Orifice	1
201	Rotor Housing	1
202	Inlet Cover	1
203	Hex Bolt	4 (size 95 thru 162 sizes only) 8 (size 187 & 200 sizes only)
204	Inboard Cover	1
205	Hex Bolt	4 (95 thru 162 sizes only)
213	Key	1
227	Cap Screw	4 (95 thru 162 sizes only)
232	Thrust Plate	1 (187 and 200 size only)
233	Tube	2 (187 and 200 size only)
234	Hex Nut	2 (187 and 200 size only)
235	Lock Washer	2 (187 and 200 size only)
307	Power Rotor	1
308	Idler Rotor	2
430	O Ring	2
432	O-Ring	1

### MAINTENANCE

	<b>WARNING</b>	
BEFORE working on equipment, make sure all power to the equipment is disconnected.		

**GENERAL:** To perform maintenance on the Series 3E pump, the following initial conditions shall be completed prior to maintenance action. Close inlet and outlet valves and tag “Out of Service”. De-energize pump drive motor and vent all pressure from pump.

**NOTE:** Part numbers contained within parenthesis such as (103) refer to the balloon numbers as shown on Figures 4 and 5 and the IDP numbers in Table 1.

#### Tools

Standard shop tools are required for the procedures given in this manual. An accurate torque wrench must be used to tighten all hex bolts and cap screws

## **CANNED MOTOR PUMP DISASSEMBLY AND ASSEMBLY INSTRUCTIONS** *(Refer to Figures 4 and 5)*

**NOTE:** The below disassembly procedure applies to the pump only. The motor is not field repairable and must be returned to the factory for repair or replacement.

### **PUMP REMOVAL AND DISASSEMBLY**

#### **Pump Disassembly For Rotor Sizes 87 Through 162 (See Figure 4 )**

1. Separate pump from motor by removing bolts (205) and O-ring (432).
2. Remove key (213) from power rotor (307).
3. Remove hex bolts (203) and inlet cover (202) with O-ring (430) from rotor housing (201).
4. Remove idler rotors (308) by unscrewing them from housing ((201).
5. Remove four cap screws (227) with fastener seal (426) and inboard cover (204) from rotor housing (201).
6. Remove O-ring (431) from inboard cover (204).
7. Remove power rotor (307) from rotor housing (201).

#### **Pump Disassembly For Rotor Sizes 187 and 200 (See Figure 5)**

1. Separate pump from motor by removing bolts (203) and O-ring (432).
2. Remove bolts (203) from inlet cover (202) and separate inlet cover (202) from outlet cover (204). Remove O-ring (430).
3. Remove assembled housing (201) being careful not to let rotor set drop out of housing (201). Removal of housing (201) includes removal of the rotor set and thrust plate assembly.
4. Remove power rotor (307) and idlers (308) from housing (201). Be careful not to drop rotor set when removing.
5. Remove bolts (234), lock washers (235), spacers (233) and thrust plate (232) from housing (201).

### **PUMP REASSEMBLY AND INSTALLATION**

**NOTE:** Imo Pump recommends replacement of O-rings when these parts are disturbed from their original installed positions.

**NOTE:** Prior to pump re-assembly, check each part and remove any burrs, then wipe all parts with lubricating. Rotate power rotor frequently during assembly to assure rotational clearances.

#### **Pump Re-assembly For Rotor Sizes 87 Through 162 (See Figure 4)**

1. Install power rotor (307) in housing (201).
2. Install O-ring (431) on cover (204).
3. Install cover (204) on rotor housing (201) using cap screws (227) with fastener seals (426) installed. Be sure power rotor (307) meshes with bore in cover (204). Torque cap screws (227) to values on assembly drawing.
4. Install idlers (308) into housing (201) by meshing their threads with the power rotor (307) thread and screwing them into the housing (201) idler bores. (The end of the idlers with the full thread run-out should be facing the coupling end of the housing (201).)
5. Install O-ring (430) on rear cover (202) and rear cover (202) on rotor housing (201) using hex bolts (203). Torque bolts per values on assembly drawing.
6. Be sure power rotor (307) turns freely by hand.
7. Install key (213) in power rotor (307) keyway.
8. Install O-ring (432) on motor front cover.
9. Install pump onto motor with hex bolts (205). Be sure key (213) in pump shaft engages keyway in motor shaft. Torque bolts per values on assembly drawing (Figure 4).

### **Pump Re-assembly For Rotor Sizes 187 and 200 (See Figure 5)**

1. Install idlers (308) into housing (201). (The end of the idler ends with full thread run-out should be facing the coupling end of the housing (201).)
2. Install spacers (233) and thrust plate (232) to housing (201) using bolts (234) and lock washers (235). Torque bolts per values on assembly drawing, Figure 4.
3. Screw in power rotor (307) in housing assembly (201) by meshing its thread with the threads on the idlers (308).
4. Install O-ring (430) into outlet cover (204).
5. Install housing (201) assembly into outlet cover (204).
6. Install inlet cover (292) on outlet cover (204) using bolts (203). Torque bolts per values on assembly drawing.
7. Install O-ring (432) on motor front cover.
8. Install pump onto motor with hex bolts (205). Be sure key (213) in pump shaft engages keyway in motor shaft.



#### **WARNING**

After assembly and prior to testing, reinstalling or operating unit , perform a high potential test per NEMA MG1-1993 Section 1, Part 3.

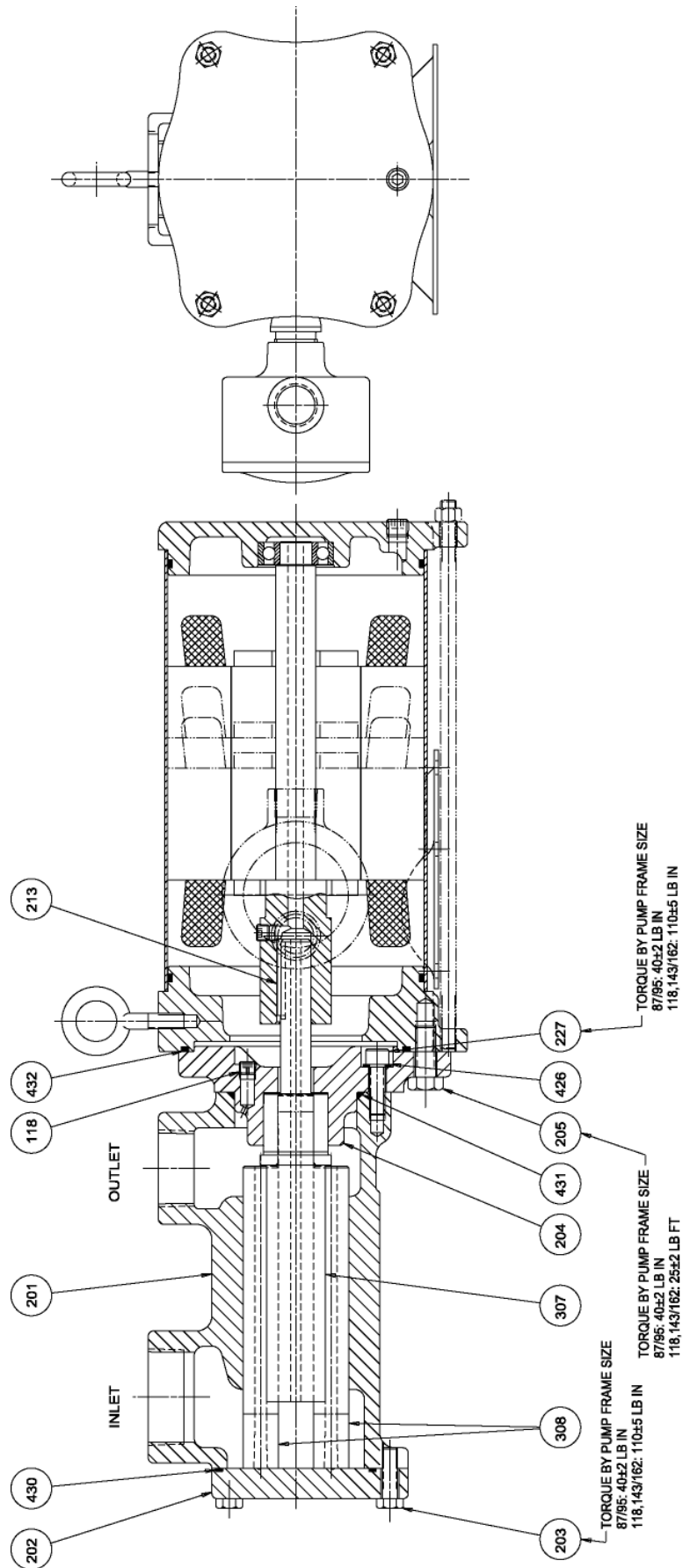

Figure 4



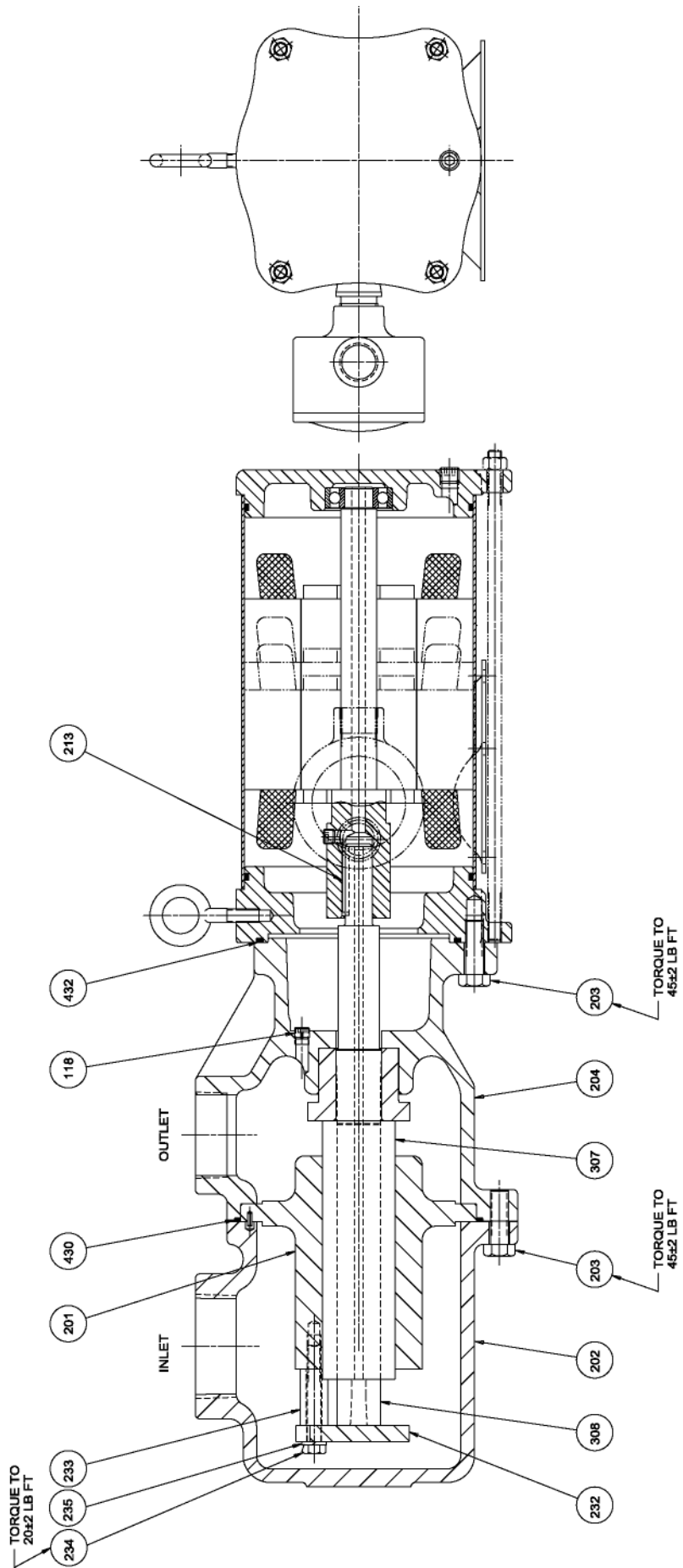

Figure 5







ALLWEILER



HOUTTUIN



IMO PUMP



WARREN



A MEMBER OF THE  
COLFAX PUMP GROUP

**Imo Pump**

1710 Airport Road  
PO Box 5020  
Monroe, NC USA  
28111.5020

tel 704.289.6511

fax 704.289.9273

email [Imo.Pump@ColfaxCorp.com](mailto:Imo.Pump@ColfaxCorp.com)

web [WWW.IMO-PUMP.COM](http://WWW.IMO-PUMP.COM)

