



**INSTRUCTION MANUAL  
AND  
PARTS LIST  
FOR  
PG/RG3D-275 SERIES PUMPS  
(Idler Cup and Hydrostatic Thrust Designs)**



**WARNING**

**This Instruction Manual and General Instructions Manual, CA-1, should be read thoroughly prior to pump installation, operation or maintenance.**

**Manual No. SRM00081**

**Rev. 00**

**September 2006**



## READ THIS ENTIRE PAGE BEFORE PROCEEDING

FOR SAFETY OF PERSONNEL AND TO PREVENT DAMAGE TO EQUIPMENT, THE FOLLOWING NOMENCLATURE HAS BEEN USED IN THIS MANUAL:

	<b>DANGER</b>	
Failure to observe precautions noted in this box can result in severe bodily injury or loss of life.		

	<b>WARNING</b>	
Failure to observe precautions noted in this box can cause injury to personnel by accidental contact with equipment or liquids. Protection should be provided by user to prevent accidental contact.		

	<b>CAUTION</b>		<b>ATTENTION</b>
Failure to observe precautions noted in this box can cause damage or failure of equipment.			

Non compliance of safety instructions identified by the following symbol could affect safety for persons:  <div style="text-align: center;"></div>	Safety instructions where electrical safety is involved are identified by:  <div style="text-align: center;"></div>	Safety instructions which shall be considered for reasons of safe operation of pump and/or protection of pump itself are marked by the sign:  <div style="text-align: center;"><b>ATTENTION</b></div>
---	--	---

<b>ATTENTION</b>
If operation of pump is critical to your business, we strongly recommend you keep a spare pump or major repair kit in stock at all times. As a minimum, a minor repair kit (o-rings, O-rings, shaft seal and bearings) should be kept in stock so pump refurbishment after internal inspection can be accomplished.

### CONTENTS

Safety and Table of Contents .....	A
A. General Instructions.....	1
B. Introduction .....	1
C. Description of Equipment.....	1
D. Pump Model Identification.....	2
E. Ordering Instructions.....	2
F. Operation .....	3
G. Parts List.....	4
H. Pump Maintenance .....	4
I. Troubleshooting .....	9
J. Field and Factory Service and Parts.....	9
K. Assembly Drawings .....	10
L. Mechanical Seal Drawings.....	11

## A. GENERAL INSTRUCTIONS

The instructions found herein cover the disassembly, assembly and parts identification of PG/RG3D-275 series pumps. Both the original design with idler cups and the newer design with hydrostatic idlers are covered.

**NOTE:** Individual contracts may have specific provisions that vary from this manual. Should any questions arise which may not be answered by these instructions, refer to the General Instructions Manual, CA-1, provided with your order. For further detailed information and technical assistance please refer to Imo Pump, Technical/Customer Service Department, at (704) 289-6511.

This manual cannot possibly cover every situation connected with the installation, operation, inspection, and maintenance of equipment supplied. Every effort was made to prepare text of manual so that engineering and design data is transformed into the most easily understood wording. Imo Pump must assume personnel assigned to operate and maintain supplied equipment and apply this instruction manual have sufficient technical knowledge and are experienced to apply sound safety and operational practices which may not be otherwise covered by this manual.

In applications where equipment furnished by Imo Pump is to become part of processing machinery, these instructions should be thoroughly reviewed to ensure proper fit of said equipment into overall plant operational procedures.

	<b>WARNING</b>
If installation, operation, and maintenance instructions are not correctly and strictly followed and observed, injury to personnel or serious damage to pump could result. Imo Pump cannot accept responsibility for unsatisfactory performance or damage resulting from failure to comply with instructions.	

## B. INTRODUCTION

This instruction manual covers series PG/RG3D-275 Imo pumps. This series of pumps has been designed for use in hydraulic, lubricating, seal, distillate, residual, fuel and crude oil applications. The model and design construction of each pump can be identified by the designator code on the pump nameplate. Definitions of model designators are identified in figure 1.

## C. DESCRIPTION OF EQUIPMENT

PG/RG3D-275 Series pumps are positive displacement, rotary screw pumps consisting of a precision bored housing which encloses a driven screw (power rotor) and two intermeshing following screws (idler rotors). These screws when rotating form a succession of closures or cavities. As they rotate, fluid is moved axially from inlet port to outlet port in a continuous, uniform flow with minimum fluid pulsation and pump noise.

## D. PUMP MODEL IDENTIFICATION

This instruction manual covers Imo Series PG/RG3D-275 pumps. The model of each pump is identified on pump nameplate. Refer to figure 1 and table 1 for instructional keys when using this manual.

**Figure 1 – Model Designator Definitions**

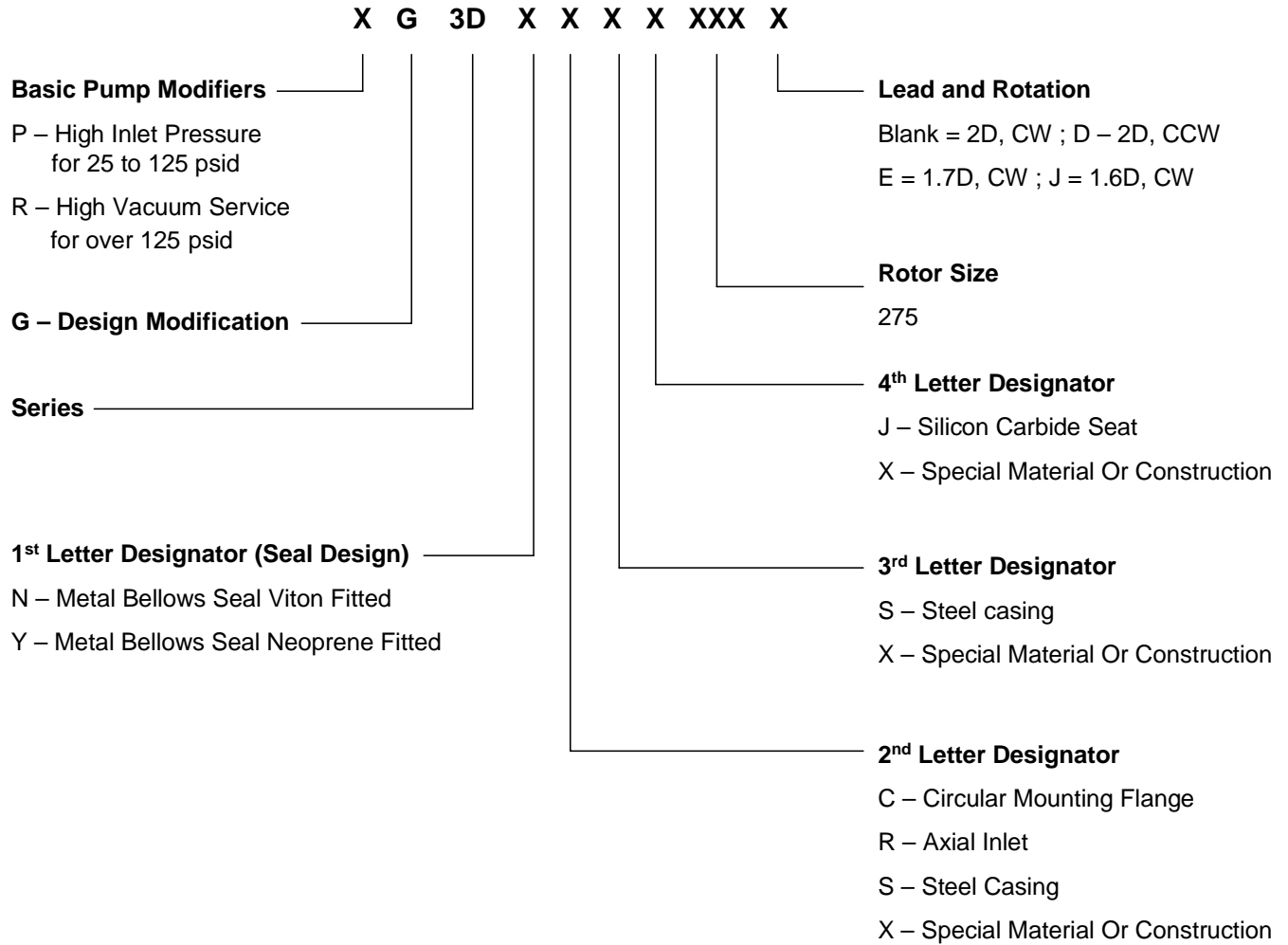

## E. ORDERING INSTRUCTIONS

When corresponding with Imo Pump regarding Series PG/RG3D-275 series pumps, refer to pump nameplate, this instruction manual, and assembly drawing as instructed below:

1. From pump nameplate, record pump model number, serial number, and manufactured date.
2. Record instruction manual number, revision, and date.
3. From instruction manual, record figure numbers that apply to replacement part(s).
4. From assembly drawing (see figure 2) or parts list (see table 2) provide IDP number(s) and names for replacement part(s).
5. Give above information to your Imo service representative.

Imo sales and service representatives are listed herein and in General Instruction Manual, CA-1.

## F. OPERATION

### F.1 LIQUID LIMITATIONS

Never operate with thin liquids such as solvents or water. Pump is designed for liquids having general characteristics of oil.

### F.2 OPERATING LIMITS

CAUTION	ATTENTION
<p>Operating conditions, such as speed, fluid viscosity, temperature, inlet pressure, discharge pressure, filtration, duty cycle, drive type, mounting, etc., are interrelated. Due to these variable conditions, specific application limits may be different from operational limitations. Equipment must not be operated without verifying system operating requirements are within pump's capabilities.</p>	

**Under no circumstances are the following operating limits (specified in table 1) to be exceeded without specific approval from Imo Pump.**

**Table 1 – Normal Pump Operating and Structural Limits**

Condition	Limit
Maximum Speed	2500 rpm
Minimum Viscosity	32 SSU
Maximum Viscosity (figure 1)	2500 SSU
Minimum Liquid Temperature	0°F
Maximum Liquid Temperature (figure 1)	200°F
Maximum Inlet Pressure	300 Psig
Maximum Discharge Pressure (Continuous Duty)	500 psig
Filtration	Refer to General Instruction Manual, CA-1
Drive	Direct or Belt
Mounting	Foot mounted in any attitude

## G. PARTS LIST

Table 2 – Pump Parts List

IDP	QTY	DESCRIPTION	KIT	IDP	QTY	DESCRIPTION	KIT
1	1	Case		18	4	Hex Bolts	
2	1	Housing	XX	19	2	Idler Rotor	XX
3	1	Pipe Plug		20	2	Idler Cups (Idler Cup Design Only)	XX
4	1	Anti-Rotation Tube	XX	21	1	Thrust Plate	XX
5	2	O-ring	X	22	2	Thrust Spacer	
6	1	O-ring	X	23	2	Hex Cap Screws	
7	1	O-ring	X	24	2	Washer	
9	1	Inboard Cover		25	1	Mechanical Seal	X
10	16	Hex Bolts		26	1	Inlet	
11	1	Power Rotor	XX	28	1	Spacer	
13	2	Retaining Rings	X	38	1	Seal Spacer	X
14	1	Spacer/Seal Seat Adapter		68	3	Pipe Plug	
15	1	Bearing	X	72	1	O-ring	X
16	1	Key	X	81	1	O-ring*	X
17	1	Bearing Retainer		86	1	Bushing	XX

X = Minor Repair Kit Items.  
 XX = Major Repair Kit Items. (Items marked (X) are included in Major Repair Kit.)

## H. PUMP MAINTENANCE

	<b>WARNING</b>
<p>Failure to observe precautions while installing, inspecting and maintaining pump can cause injury to personnel from accidental handling of liquids that may harm skin or clothing, or fire hazard risks from flammable liquids, or injury from high pressure fluid jets.</p>	

	<b>DANGER</b>
<p><b>BEFORE</b> working on equipment, make sure all power to equipment is disconnected and locked-out.</p>	

### H.1 GENERAL COMMENTS

**NOTE:** Part number identifiers (IDP) contained within parenthesis, such as (9), refer to circled numbers shown on assembly drawing, figure 2.

De-energize driver before starting with any maintenance action.

## H.2 TOOLS REQUIRED

Procedures described in this manual require common mechanics hand tools, a torque wrench, dial indicators for alignment and a suitable lifting device such as slings, straps, etc.

## H.3 MECHANICAL SEAL AND BEARING MAINTENANCE

The following procedures detail servicing the pump mechanical seal and ball bearings only.

Refer to pump assembly shown by figure 2 and mechanical seal assembly shown by figure 3 for the following instructions.

1. Close suction and discharge piping to pump. Vent pressure from pump. Disconnect piping. Remove drain plug (68) and drain unit. Remove pump from driver, coupling and base plate. Remove coupling hub and key (16).
2. Remove bearing retainer (17) from inboard cover (9) by removing bolts (18).
3. Remove assembled power rotor (11) from inboard cover (9). Removal of power rotor (11) includes removal of snap rings (13), ball bearing (15), seal spacer (38), seal seat adapter (14) and mechanical seal (25).
4. Disassemble power rotor (11) as follows:
  - a. Using a flat nosed tool, such as a screw driver, remove snap ring (13) located on coupling side of ball bearing (15) from groove in power rotor (11).
  - b. Sealed ball bearing (15) is assembled to power rotor (11) with light press fit. Ball bearing (15) may be removed by using bearing puller or vertical arbor press. When using press, place two pieces of key stock through openings of mechanical seal seat adapter (14) underneath ball bearing (15) on both sides of power rotor shaft. Key stock should be long enough to support power rotor (11) as it is placed in press. Position press ram against power rotor (11) coupling end face. Gently press power rotor (11) through ball bearing (15). Ensure power rotor (11) does not fall to floor once ball bearing (15) is off of its diameter.
  - c. Remove thread side snap ring (13).
  - d. Remove seal seat adapter (14) with stationary seal seat. Remove stationary seat with O-ring from seal seat adapter (14). Discard O-ring.
  - e. Remove rotating seal seat by disengaging set screw, then sliding seal seat off shaft (11).
  - f. Remove spacer (38) from shaft.
5. Remove O-ring (81) from inboard end cover (9).

6. Inspect power rotor (11) shaft and remove any nicks or burrs which are present. Polish power rotor shaft to remove any rust or oxidants that may be present under shaft sleeve. Imo pump recommends replacement of ball bearing (15), mechanical seal (25), and O-ring (81) when these parts are disturbed from their original installed position. All parts should be coated with light lubricating oil to assist in assembly.
7. Assemble power rotor (11) and mechanical seal (25) as follows:
  - a. Assemble spacer (38) onto shaft (11).
  - b. Slide mechanical seal rotating assembly on power rotor (11) until it seats against seal spacer (38). Tighten seal set screw on shaft.
  - c. Wipe seal face with isopropyl alcohol and a lint free rag.
  - d. Install O-ring in groove of mechanical seal stationary seat. Install seat including O-ring in seal seat adapter (14) ensuring that groove in back of stationary seat mates to spring pin in seal seat adapter (14). Clean seal face with isopropyl alcohol and a lint free rag. Put a small amount of clean system fluid or light oil on seal running face. Install the rotating ring running face against the stationary seat face.
  - e. Install inner snap ring (13) in groove of power rotor (11).
  - f. Press bearing (15) on power rotor (11), pressing only on inner race of ball bearing (15) using an installation sleeve until it is located next to inner snap ring (13).
  - g. Install outer snap ring (13) in groove of power rotor (11).
8. Install O-ring (81) in seal bore of inboard cover (9).
9. Install assembled power rotor (11) in pump, centering all parts as they enter inboard cover (9). Align one of openings in spacer (14) over drain in inboard cover (9).
10. Install bearing retainer (17) on inboard cover (9) using bolts (18) (and lockwashers (30) if present). Torque bolts (18) to value indicated on assembly drawing, figure 2.



## H.4 PUMP DISASSEMBLY



### CAUTION

Fluid leakage from disassembly of pump may make the floor slippery and can cause personal injury

**NOTE:** The PG/RG3D-275 pumps incorporate highly finished precision parts that must be handled carefully to avoid damage to critical machined surfaces. The parts removed should be tagged for identification and their exact positions in the pump carefully noted so that new parts, or the same parts, are properly replaced without damage.

Refer to pump assembly shown in figure 2 for the following instructions.

1. Close suction and discharge piping to pump. Vent pressure from pump. Disconnect piping. Remove drain plug (68) and drain unit. Remove pump from driver, coupling and base plate. Remove coupling hub and key (16).
2. Remove inlet head (26) from case (1) by removing bolts (10). Remove and discard O-ring (72) from inlet head (26).
3. Remove thrust plate (21) and spacers (22) by removing bolts (23) and lock washers (24).
4. If idler cup design, remove cups (20) from idlers (19).
5. Remove idlers (19) from housing (2) by unscrewing them from housing bores.

### CAUTION

### ATTENTION

Do not permit idlers (19) to drop as they emerge from housing (2).

6. Remove housing spacer (28) from case (1).
7. Remove shaft (11) with ball bearing (15) and seal (25) by performing procedures in paragraph H.3 steps (2) through (6).
8. Remove inboard cover (9) by removing bolts (10).
9. Press bushing (86) from cover (9). Cover may require heating to loosen Loctite before bushing (86) can be removed. Do not heat to more than 250°F.
10. Remove and discard O-ring (7) from inboard cover (9).
11. Remove tube (4) with O-rings (5) from housing (2). Discard O-rings (5).
12. Remove housing (2) and O-ring (6) from inlet end of case (1). Discard O-ring (6).

## H.5 PUMP ASSEMBLY

**NOTE:** Prior to reassembly of pump, clean and inspect all parts for nicks and burrs. Replace all worn or damaged parts. Imo Pump recommends replacement of all O-rings (6), mechanical seal (25), and ball bearing (15) when these parts are disturbed from their previously installed positions. Coat all parts with light lubricating oil to assist in assembly.

1. Install O-ring (6) in groove in housing (2). Install O-rings (5) in grooves in tube (4) and install tube (4) in housing (2).
  2. Install housing (2), O-ring end first, in pump case (1) from suction end.
  3. Clean and dry inboard cover (9) and balance piston bushing (86) mating surfaces with solvent. Wipe Loctite "T747" Primer or equivalent onto the mating surfaces of bushing (86) and inboard cover (9). Allow 1 to 5 minutes until primer is visibly dry. Apply Loctite 609 or equivalent to bushing (86) and inboard cover (9) mating surfaces.
  4. Assemble bushing (81) into inboard cover (9). Allow 10 minutes to dry before proceeding with assembly.
  5. Install O-ring (7) on inboard cover. Install inboard cover (9) into discharge port side of case (1) using bolts (10). Ensure pin (4) in housing mates with hole in inboard cover (9). Torque bolts (10) to value indicated on assembly drawing, figure 2.
  6. Assemble mechanical seal and ball bearings by performing procedures in paragraph H.3, steps 7 through 10.
  7. Install idlers (19) into housing (2) by meshing threads with power rotor thread.
  8. If idler cup design, install cups (20) on idlers (19).
  9. Install spacer (28) on discharge end of case (1) flush with edge of housing (2).
  10. Install bolts (23) and lock washers (24) in thrust plate (21). Install spacers (22) on bolts (23).
  11. Install thrust plate assembly including thrust plate (21), washers (24), bolts (23) and spacers (22) on housing (2). Torque bolts (23) to value indicated on assembly drawing, figure 2.
  12. Install O-ring (72) in groove in inlet head (26).
  13. Install inlet head (26) using bolts (10). Torque bolts to value indicated on assembly drawing, figure 2.
- NOTE:** Inlet head (26) can be rotated and repositioned in 90 degree increments to suit suction piping. To change inlet position remove bolts (10) and rotate inlet head to desired position. Install bolts (10) and torque to proper values indicated on assembly drawing, figure 2.
14. Install coupling hub key (16). Install and align pump and driver as specified in General Instruction Manual, CA-1.

## **I. TROUBLESHOOTING**

For assistance with troubleshooting see the General Instruction Manual, CA-1.

## **J. FIELD AND FACTORY SERVICE AND PARTS**

Imo Pump maintains a staff of trained service personnel that can provide pump installation, pump start-up, maintenance/overhaul and troubleshooting supervision as well as installation and maintenance training.

Our factories provide maintenance as well as overhaul and test facilities the in event user prefers to return pumps for inspection or overhaul. Factory-overhauled pumps are normally tested and warranted "as-new" for a period of one year from date of shipment. For either field service or factory overhaul assistance, contact your local Imo Sales Office or representative at Technical/ Customer Service Department in Monroe, NC, USA.

Most pumps have repair kits available. Minor Repair Kits are used to repair leaking seals, bad bearings and/or for re-assembly after pump tear-down. They include (as applicable) pump shaft seals, packing, all O-rings/O-rings and bearings. Major Repair Kits are sufficient to rebuild completely worn-out pumps to "as-new" condition. They include all parts found in Minor Repair Kits plus all major internal parts subject to wear. Since kits have all necessary parts, kit purchase is preferred rather than selecting individual parts. When parts are individually selected from Parts List, some needed components are often overlooked. In addition, mixing worn or used parts with new parts risks rapid wear and shortened service life from new parts.

FIGURE 2: PG/RG3D\_S\_ - 275\_

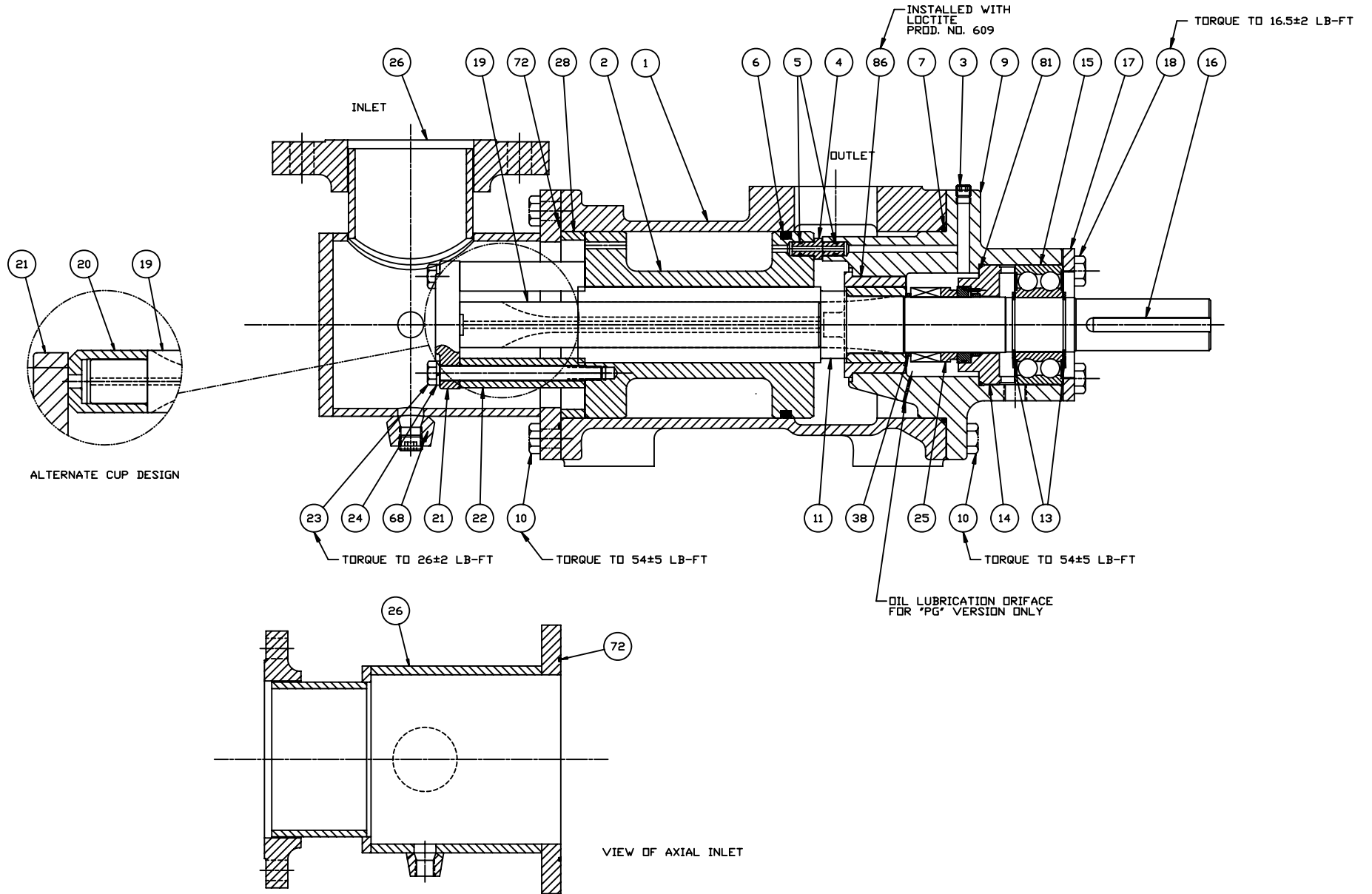
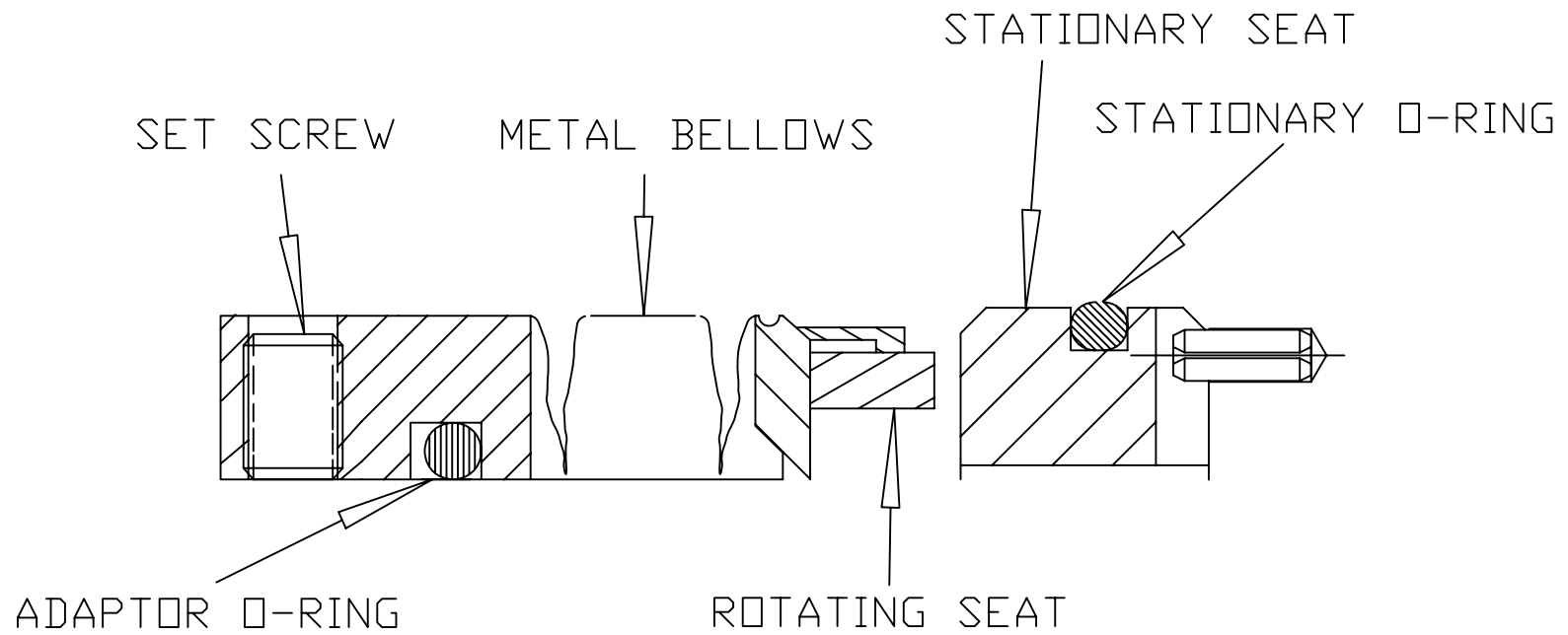

FIGURE 3: METAL BELLOWS TYPE MECHANICAL SEAL





ALLWEILER



HOUTTUIN



IMO PUMP



WARREN



A MEMBER OF THE  
COLFAX PUMP GROUP

**Imo Pump**

1710 Airport Road  
PO Box 5020  
Monroe, NC USA  
28111.5020

tel 704.289.6511

fax 704.289.9273

email [Imo.Pump@ColfaxCorp.com](mailto:Imo.Pump@ColfaxCorp.com)

web [WWW.IMO-PUMP.COM](http://WWW.IMO-PUMP.COM)

